



Owner's Manual

MERIVA

Operation, Safety and Maintenance



VAUXHALL Meriva

Operation, Safety, Maintenance

Data specific to your vehicle

Please enter your vehicle's data here to keep it easily accessible.

This information is available under the section "Technical data" as well as on the identification plate and in the Service Booklet.

Fuel

Designation

Engine oil

Grade

Viscosity

Tyre pressure

	Tyre size	with up to 3 persons		with full load	
Summer tyres	<input type="text"/>	Front <input type="text"/>	Rear <input type="text"/>	Front <input type="text"/>	Rear <input type="text"/>
Winter tyres	<input type="text"/>	Front <input type="text"/>	Rear <input type="text"/>	Front <input type="text"/>	Rear <input type="text"/>

Weights

Permissible Gross Vehicle Weight

– EC kerbweight

= Loading

Your Meriva

is an intelligent combination of forward-looking technology, impressive safety, environmental friendliness and economy.

It now lies with you to drive your vehicle safely and ensure that it performs perfectly. This Owner's Manual provides you with all the necessary information to that end.

Make sure your passengers are aware of the possible risk of accident and injury which may result from improper use of the vehicle.

You must always comply with the specific laws of the country that you are travelling through. These laws may differ from the information in this Owner's Manual.

When this Manual refers to a workshop visit, we recommend your Vauxhall Authorised Repairer.

All Vauxhall Authorised Repairers provide first-class service at reasonable prices.

You will receive quick, reliable and individual service.

Experienced mechanics, trained by Vauxhall, work according to specific Vauxhall instructions.

The Owner's Manual should always be kept in the vehicle: Ready to hand in the glove compartment.

Make use of the Owner's Manual:

- The "In Brief" section will give you an initial overview.
- The table of contents at the beginning of the owner's manual and within the individual chapters will show you where everything is.
- Its index will help you find what you want.
- It will familiarise you with the sophisticated technology.
- It will increase your pleasure in your vehicle.
- It will help you to handle your vehicle expertly.

The Owner's Manual is designed to be clearly laid-out and easily understood.

This symbol signifies:

► Continue reading on next page.

✱ Items marked with an asterisk are not fitted to all vehicles (model variants, engine options, models specific to one country, optional equipment, Genuine Vauxhall Parts and Accessories).

Warning

Text marked  **Warning** provides information on risk of accident or injury. Disregard of the instructions may lead to injuries or endanger life. Inform your passengers accordingly.

Yellow arrows in the illustrations serve as points of reference or indicate some action to be performed.

Black arrows in the illustrations indicate a reaction or a second action to be performed.

Directional data, e.g. left or right, or front or back, in the descriptions always relate to the direction of travel.

We wish you many hours of pleasurable driving

Your Vauxhall Team

Contents

Commitment to customer satisfaction:

Our aim: to keep you happy with your vehicle. All Vauxhall Authorised Repairers offer first-class service at competitive prices. Experienced, factory-trained technicians work according to factory instructions. Your Authorised Repairer can supply you with GENUINE VAUXHALL-APPROVED PARTS, which have undergone stringent quality and precision checks, and of course useful and attractive VAUXHALL-APPROVED ACCESSORIES.

Our name is your guarantee!

For details of the

Vauxhall Authorised Repairer Network, please ring this number; 0845 090 2044

In Brief	2
Keys, Doors, Windows	26
Seats, Interior	43
Instruments, Controls	84
Lighting	105
Infotainment System	114
Climate Control	117
Driving and Operation	132
Self-help, Vehicle Care	170
Technical Data	206
Service, Maintenance	224
Index	238

In Brief



To unlock and open the doors: Press button and lift door handle

All doors and the luggage compartment are unlocked.

Country-specific version *:
Pressing once unlocks the driver's door, and pressing twice unlocks the entire vehicle.

► Door locks – see page 26,
keys – see page 26,
electronic immobiliser – see page 27,
radio frequency remote control –
see page 28,
central locking – see page 30,
Vauxhall alarm system * – see page 34.

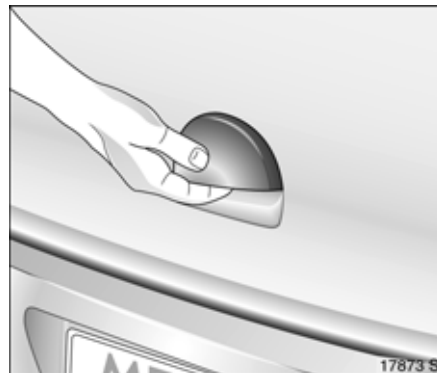

To unlock and open the luggage compartment: Press button on remote control and operate button beneath handle

► Radio frequency remote control –
see page 28,
central locking – see page 30,
Vauxhall alarm system * – see page 34.

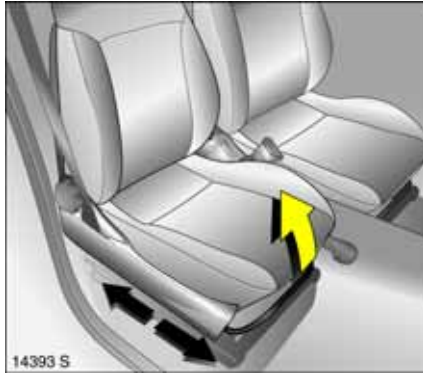

**To adjust front seats:
Pull handle,
slide seat,
release handle**

► Seats – see page 43,
seat position – see page 44.

⚠ Warning

Important: Do not sit nearer than
10 inches (25 cm) from the steering
wheel, to permit safe airbag deployment.

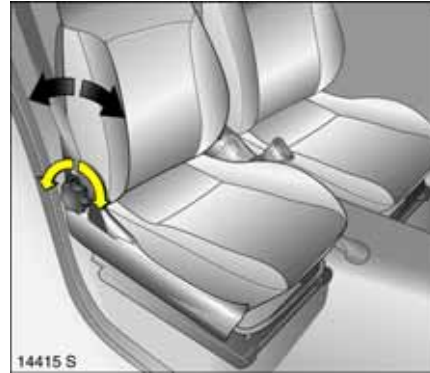

**Adjust front seat backrests:
Turn handwheel**

Move backrest to suit seating position.

Do not lean on seat backrest while
adjusting it.

► Seats – see page 43,
seat position – see page 44.

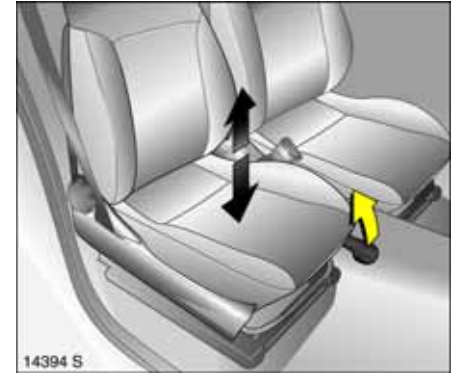

**To adjust front seat height:
Pull front lever at side**

Lift lever and relieve some weight from seat
to raise it or press down on seat cushion
with body weight to lower it.

► Seats – see page 43,
seat position – see page 44.



**To adjust head restraint height of front and rear outboard seats:
Tilt head restraint forward to release,
hold and adjust height,
engage**

- ▶ Head restraints – see page 45,
rear centre head restraint – see page 45,
head restraint position – see page 46,
head restraint removal – see page 46.



**To fit seat belt:
Draw seat belt smoothly from
inertia reel, guide over shoulder
and engage in buckle**

The seat belt must not be twisted at any point. The lap belt must lie snugly against the body. The front seat backrests must not be tilted back too far (recommended maximum tilting angle approx. 25°).

To release belt, press red button on belt buckle.

- ▶ Three-point seat belts – see page 58,
airbag system – see page 67,
seat position – see page 44.



**To adjust exterior mirrors:
From inside,
swivel lever in required direction**

- ▶ Mirrors – see page 37,
further information, aspherical exterior
mirror * – see page 37.



To adjust electrically adjustable exterior mirrors *:

Four-way switch in driver's door

Toggle rocker switch to left or right:

Four-way switch moves appropriate mirror.

► Mirrors – see page 37,
fold-in exterior mirrors – see page 37,
further information, a spherical exterior
mirror, heated exterior mirrors * –
see pages 12, 37, 119.



Adjusting interior mirror: Swivel mirror housing

Swivel lever on underside of mirror housing
to reduce dazzle at night.

► Interior mirror – see page 38,
automatic anti-dazzle interior mirror * –
see page 38.

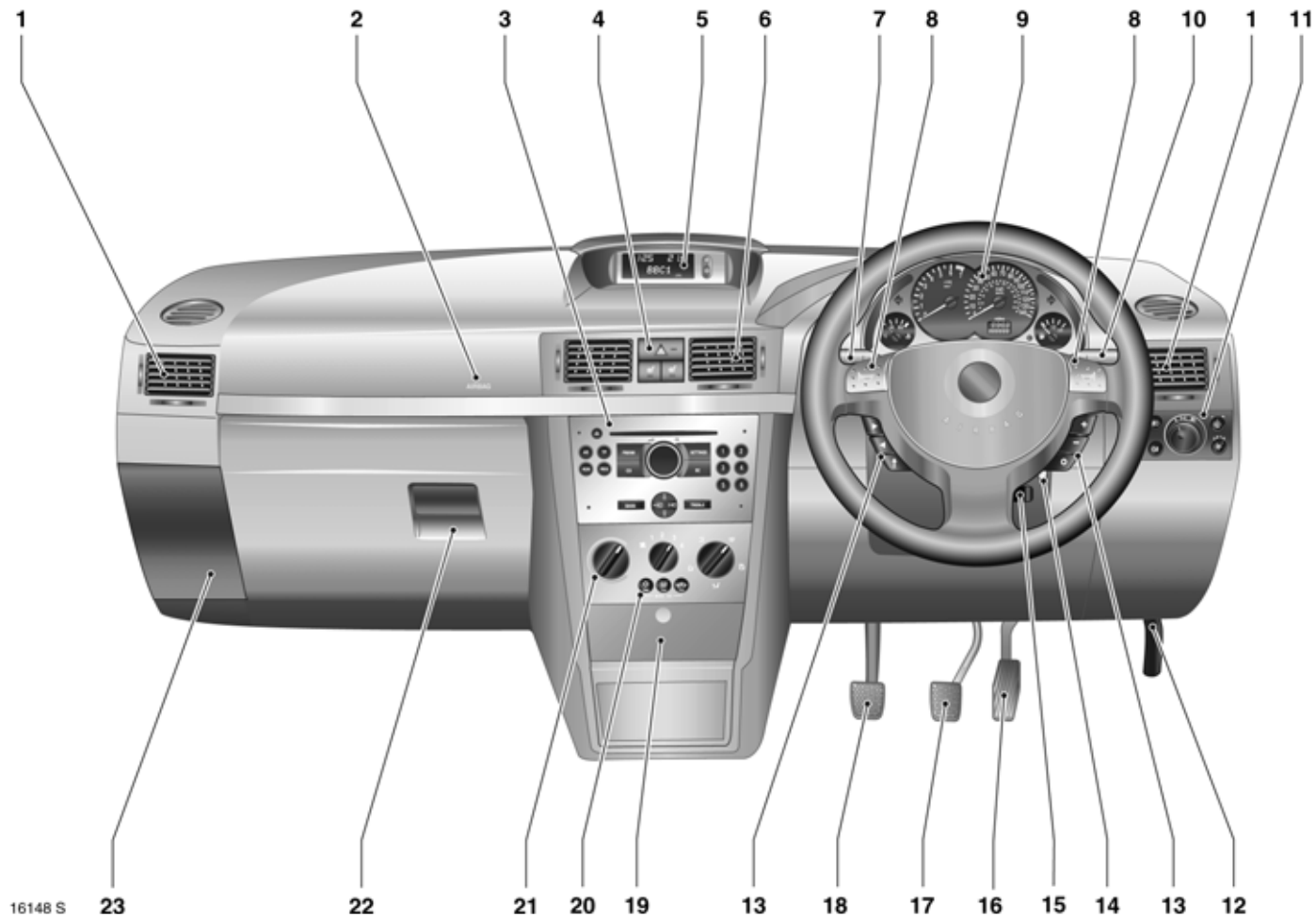





















	Page
1 Side air vents	118
2 Front passenger's airbag	67
3 Infotainment system *	114
4 Hazard warning lights	10, 107
LED for	
Vauxhall alarm system *	34
Heated seats *	119
5 Central information display for time, date, outside temperature, Infotainment system *	92
6 Centre air vents	118
7 Turn signal light, headlight flash, dipped beam, high beam	10
Door-to-door lighting function	110
Cruise control *	151
8 Horn	11
9 Instruments	84

	Page
10 Windscreen wiper, windscreen wash system, headlight wash system * and rear window wash system * ...	11, 103
11 Parking lights, dipped beam	105
Courtesy light	111
Instrument illumination	111
Fog tail light	107
Front fog lights *	106
Headlight range adjustment	107
12 Bonnet release lever	170
13 Remote control on steering wheel	114
14 Starter switch with steering column lock	9
15 Steering wheel adjustment *	9
16 Accelerator pedal	138, 139
17 Brake pedal	138, 154

	Page
18 Clutch pedal *	138
19 Ashtray	80
Accessory socket and cigarette lighter	79
20 Air conditioning system *	117
Heated rear window	12, 119
Air recirculation system *	123
21 Climate control	117
22 Glove compartment	81
23 Fusebox	188

Control indicators

- | | | |
|--|---|---|
| <p> Seat belt warning device *, see page 84.</p> <p> Adaptive Forward Lighting (AFL) *, see pages 84, 109.</p> <p> Front fog lights *, see pages 85, 106.</p> <p> Engine electronics, transmission electronics, immobiliser, diesel fuel filter *, Easytronic *, fault, see pages 85, 27, 147.</p> <p> Exhaust emission *, see pages 85, 147.</p> <p> Airbag systems *, belt tensioners, see pages 60, 72.</p> | <p> Engine oil pressure, see page 86.</p> <p> Turn signal lights, see pages 10, 86.</p> <p> Headlight main beam, see pages 9, 86.</p> <p> Preheating system for diesel engines *, diesel particle filter *, see page 88.</p> <p> Easytronic *, start engine *, see page 133.</p> <p> Easytronic *, winter programme, see page 135.</p> <p> Cruise control *, see page 151.</p> <p> Fog tail light, see pages 87, 107.</p> <p> Alternator, see page 87.</p> | <p> Brake system, clutch system *, see page 87.</p> <p> Anti-lock Brake System (ABS), see page 156.</p> <p> Engine oil level *, see page 88.</p> <p>EPS Electric Power Steering (EPS) *, see page 88.</p> <p> Electronic Stability Programme (ESP^{Plus}) *, see page 149.</p> <p> Fuel level, see pages 88, 143.</p> <p> Seat occupancy recognition *, see pages 73, 74.</p> |
|--|---|---|

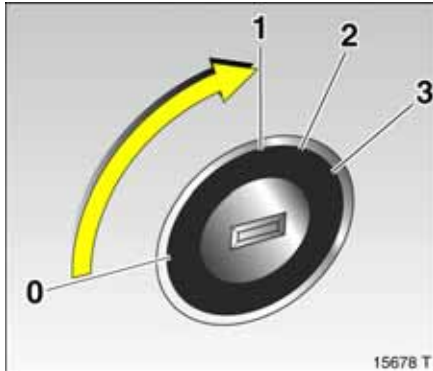

Steering column lock and ignition: Turn key to position 1; Move steering wheel slightly to release lock

Positions:

- 0 = Ignition off
- 1 = Steering free, ignition off
- 2 = Ignition on,
for diesel engines: preheating
- 3 = Starting

► Starting – see page 14,
electronic immobiliser – see page 27,
parking the vehicle – see page 15.

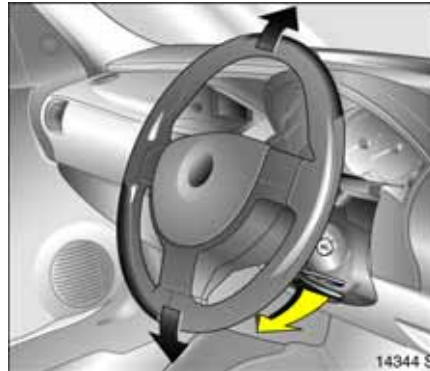

Steering wheel adjustment *: Swivel lever down, adjust height, swivel lever up, engage

Adjust steering wheel only when vehicle is stationary and steering column lock is released.

► Airbag system – see page 67.



Turn light switch:

- 0 = Off
- >€ = Parking lights
- >D = Dipped beam
or main beam

Press button:

- >D = Front fog lights *
- >€ = Fog tail light
- ☼ = Courtesy light

► Lighting – see page 105,
headlight warning device – see page 103.

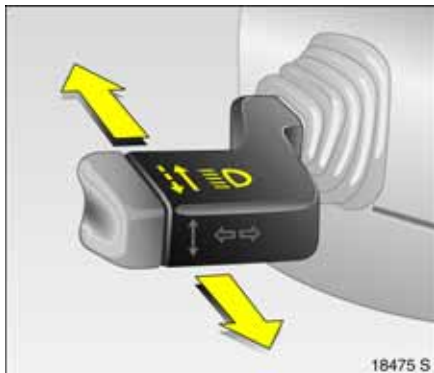

Headlight flash, main beam and dipped beam:

Headlight flash = Pull stalk towards steering wheel

Main beam = Push stalk forwards

Dipped beam = Push stalk forwards again

Main beam, headlight flash – see page 106.

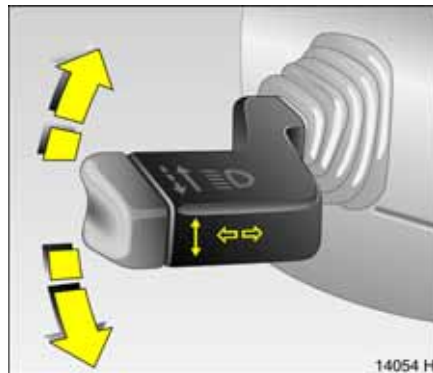

Switch on turn signal lights:

Right = Stalk up

Left = Stalk down

► Turn signal lights – see page 106.



Hazard warning lights:

On = Press 

Off = Press  again

► Hazard warning lights – see page 107.

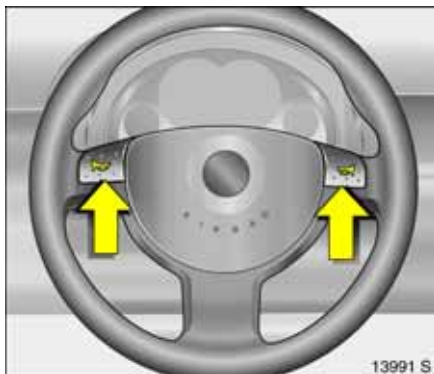

Horn operation:

Press 

► Airbag system * – see page 67,
remote control on steering wheel * –
see page 114.

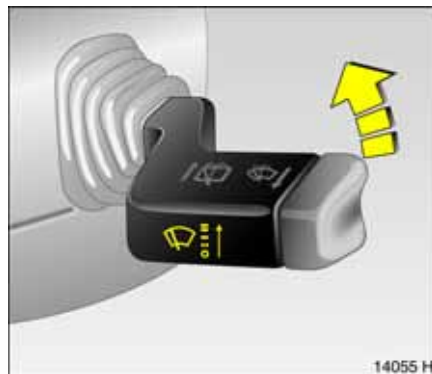

Windscreen wiper:

Stalk up

○ = Off

-- = Adjustable timed interval
wipe

— = Slow

≡ = Fast

► Windscreen wiper – see page 103,
adjustable timed interval wipe * –
see page 103,
further information – see pages 204, 233.



Operating windscreen and headlight wash systems *: Pull stalk towards steering wheel

The wiper will swipe for a few strokes.

The headlight wash system * can be
operated when the lights are on.

► Windscreen wash system –
see page 104,
further information – see pages 204, 234.



14057 H

Activate rear window wiper and wash system:

- Wiper on** = Push stalk forwards
- Wiper off** = Pull stalk towards steering wheel
- Washer** = Push stalk fully forwards and hold

► Rear window wash / wipe system – see page 104, further information – see pages 204, 235.

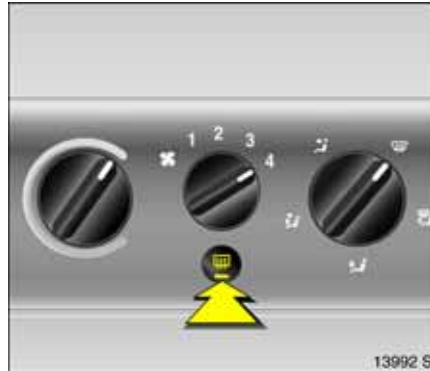

13992 S

Heated rear window, heated exterior mirrors ✱:

- On** = Press
- Off** = Press again

► Air conditioning – see page 117, heated rear window – see page 119.



13993 S

To defrost misty or icy windows: Turn rotary knob for temperature and airflow clockwise, air distribution to

Air conditioning system ✱: Press button

Electronic Climate Control system ✱:

Press button

► Climate control – see page 117, air conditioning system ✱ – see page 123, Electronic Climate Control system ✱ – see page 126.



To set automatic mode of Electronic Climate Control system *:
Press **AUTO** button, set temperature using left-hand rotary knob

► Electronic Climate Control system * – see page 126.



Manual transmission:

Reverse gear: with vehicle stationary, three seconds after declutching pull the ring up and engage gear.

If the gear does not engage, set the lever in neutral, release the clutch pedal and depress again; then repeat gear selection.

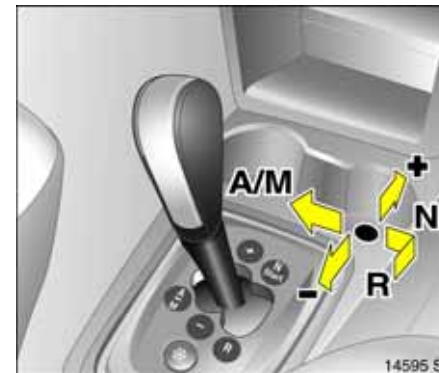

Easytronic *:

- N** = Idle / start position
- = Drive position (centre position)
- +** = Higher gear
- = Lower gear
- A/M** = Switch between Automatic mode and Manual mode
- R** = Reverse gear (with selector lever lock)

To move the selector lever from **N** to **R**, press the button on the lever.

Only start in **N** with footbrake applied.

► Easytronic * – see page 132.

Before starting-off, check:

- Tyre pressure and tyre condition, see pages 160, 216.
- Engine oil level and fluid levels in engine compartment, see pages 228 to 235.
- All windows, mirrors, exterior lighting and number plates are free from dirt, snow and ice and are operational.
- No objects are placed in front of the rear window, on the instrument panel or in the area in which the airbags inflate.
- Seats, seat belts and mirrors are correctly adjusted.
- Brake operation.

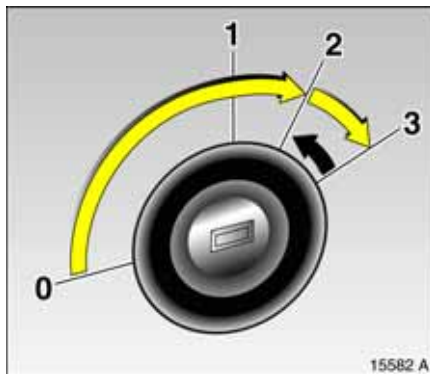
**To start engine:**

Operate clutch and brake,

Easytronic * in N,

do not accelerate,

Petrol engines: key to 3;

Diesel engines: key to 2,

when control indicator  goes out¹⁾, turn key to 3;

release key once engine is running

Before restarting or when switching off the engine, turn key back to position 0.

To switch on the ignition, only turn the key to position 2.

► Electronic immobiliser – see page 27,
diesel fuel system – see page 170,
further information – see pages 138, 171.

¹⁾ Preheating system switches on only if outside temperature is low.

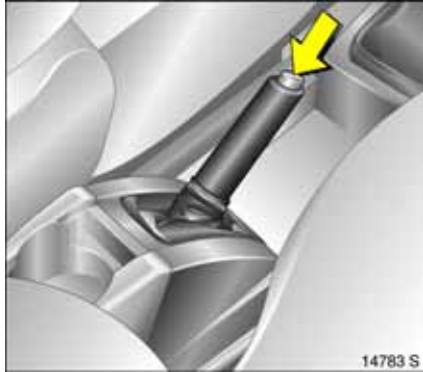

Releasing the handbrake:
 Raise lever slightly,
 press lock button,
 lower lever fully

► Handbrake – see page 155.



Parking the vehicle:
 Apply handbrake firmly,
 switch engine off,
 remove key,
 lock steering wheel,
 lock vehicle

To lock vehicle and arm the Vauxhall alarm system *, press button =.

To activate the mechanical anti-theft locking system, press button = twice.

► Further information – see pages 27, 138, radio frequency remote control – see page 28, central locking system – see page 30, Vauxhall alarm system * – see page 34, vehicle decommissioning – see page 237.

Advice when parking:

- Do not park the vehicle on flammable surfaces as combustion could occur due to the high exhaust temperatures.
 - Always apply the handbrake firmly. Apply the handbrake as firmly as possible on uphill or downhill slopes. To reduce operating forces, apply footbrake at the same time.
 - Close windows, sliding roof ✱ and tilting roof ✱.
 - With manual transmission, select first gear or reverse gear. With Easytronic ✱, move selector lever to centre position before switching ignition off.
- On vehicles with Easytronic ✱, control indicator (Ⓢ) flashes for a few seconds after the ignition is switched off if the handbrake has not been applied.
 - Turn steering wheel until lock is felt to engage (anti-theft protection) after first withdrawing the ignition key.
 - The engine cooling fans may run after the engine has been switched off, see page 227.
 - ▶ Further information – see pages 235, 237.

That was the most important information for your first drive in your Meriva in brief.

The other pages of this chapter contain a description of some interesting functions in your vehicle.

The remaining chapters of the Owner's Manual contain important information on operation, safety and maintenance as well as a complete index.

Flexible Seat System (FlexSpace)

The rear row of seats in your vehicle offers three seats or, with the centre seat lowered, two seats with more seating space. The outboard seats can be lowered to obtain a level loading surface.

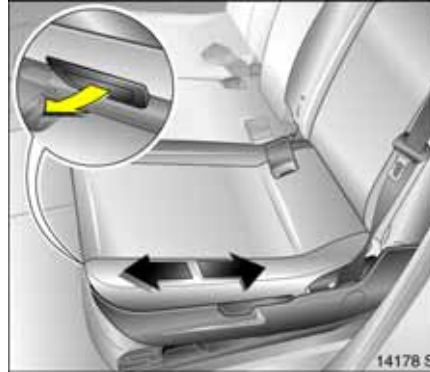

Move rear outboard seats

- Pull handle under seat,
- Slide seat,
- Release handle and allow seat to engage in position.

The backrests must not be in the rearmost position when the seats are moved back, in order to prevent damage.



Adjust or fold backrest of outboard seats

- Pull handle on outboard side of seat,
- Guide backrest into the relevant position,
- Release handle and allow seat to audibly engage in position.

The backrest can engage in several positions. In addition, the backrest can be folded all the way down to the seat cushion when extending the luggage compartment.

⚠ Warning

To prevent injuries, always hold seat backrest firmly and guide downwards when folding.



14728 S

Lower centre seat

- House centre seat belt in the belt retainer in the roof,
- Insert seat belts into recesses in seat cushion,
- Slide centre rear seat head restraint all the way down,
- Pull release handle at rear of centre seat backrest. Tilt backrest forwards and engage.



14729 S

Two rear seats with more seating space

- Lower centre seat,
- Adjust backrest to centre position,
- Pull handle beneath seat.
- Slide seat all the way back, then towards the centre of the vehicle and then further rearwards to the desired position,
- Release handle and allow seat to engage in position.



14730 S

Three seats

- Adjust backrest to centre position,
- Pull handle beneath seat.
- Slide seat all the way forwards, then out towards the door and then further forwards to the desired position.
- Release handle and allow seat to engage in position,
- Raise centre seat.

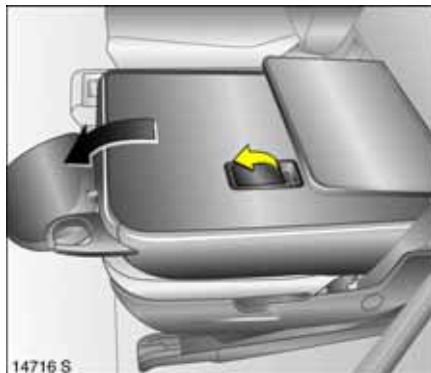

14716 S

Folding down outboard seats

- Pull seat belt from belt guide on backrest,
- Fold down outboard rear seat backrests,
- To achieve a level loading surface, pull release handle on back of backrest and push seat down until it latches into position.

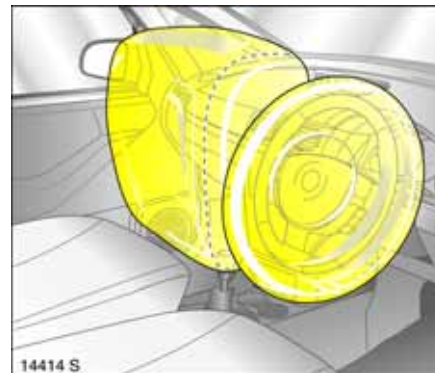

14414 S

Airbag system

The airbag system consists of several separate systems.

Front airbag system

The front airbag system will be triggered in the event of a serious accident involving a frontal impact and forms safety cushions for the driver and front passenger. The forward movement of the driver and front passenger is checked and the risk of injuries to the upper body and head are thereby substantially reduced.

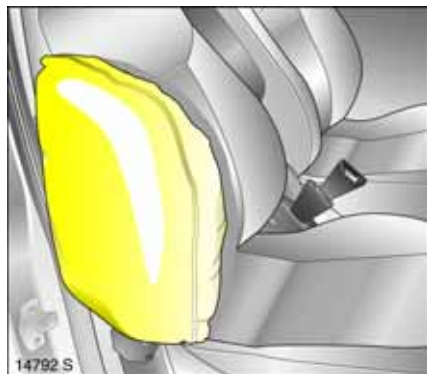

Side airbag system *

The side airbag is triggered in the event of a side-on collision to form a safety cushion for the driver or front passenger in the respective door area. This substantially reduces the risk of injury to the upper body and pelvis.

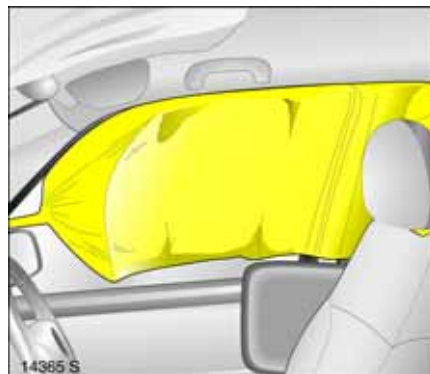

Curtain airbag system *

The curtain airbag system triggers in case of a side-on collision and provides a safety barrier in the head area on the respective side of the vehicle. This reduces the risk of injury to the head considerably in case of a side-on collision.

► Airbag systems – see page 67.

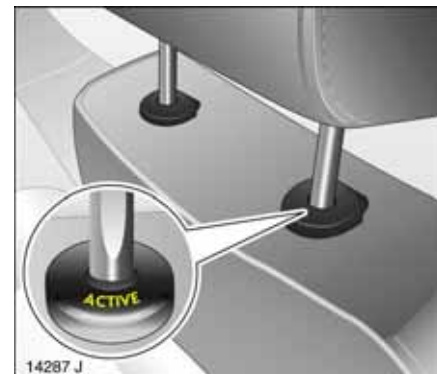

Active head restraints * on front seats

In the event of a rear-end impact, the active head restraints automatically tilt forward a little. The head is more effectively supported by the head restraint and the danger of injuries caused by whiplash in the neck area is reduced.

Active head restraints are identified by the lettering **ACTIVE** on the head restraint guide sleeves.

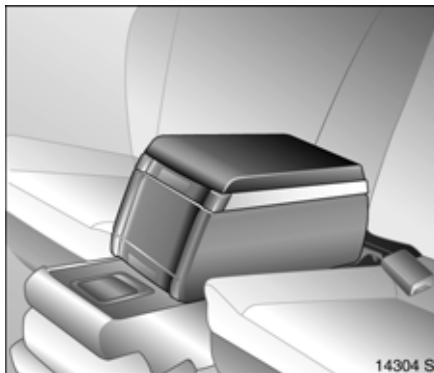

Travel Assistant *

The Travel Assistant contains:

- Arm rest,
- Tray,
- Drink holders.

The Travel Assistant is mounted on the lowered centre seat (see page 19).

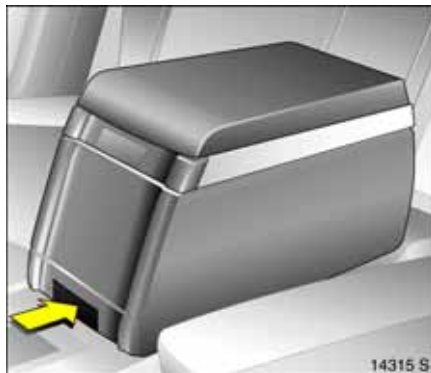

Dismantling the Travel Assistant

- Press lower button on the Travel Assistant,
- Pull Travel Assistant upwards out of recesses,
- There is a carrying handle on the back to facilitate transport.



Operating menus in the information display *

Menu options are selected using menus and using the buttons / four-way button or the multi-function knob of the Infotainment system * or the buttons * on the steering wheel. The respective menu options are shown on the display.

Selection using four-way button: press four-way button at top, bottom, left or right.



Selection using multi-function knob *:
Rotate and press multi-function knob.

To exit a menu, turn the multi-function knob left or right to **Return** or **Main** and select.



To select with steering wheel buttons:
Select menu options via the menus and the buttons.

► Information display – see page 92.

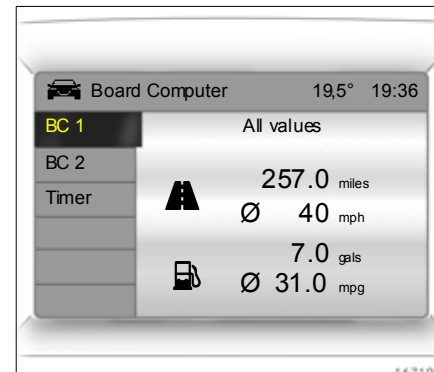

Trip computer *

The trip computers provide information on driving data, which is continually recorded and evaluated electronically.

Functions:

- Range,
- Instantaneous consumption,
- Distance travelled,
- Average speed,
- Effective consumption,
- Average consumption,
- Stop watch.

► Trip computer – see page 99.



Remote control on steering wheel *

The functions of the Infotainment system and the information display can be operated with the buttons on the steering wheel.

Further information is available in the Infotainment system operating instructions.



Twin Audio *

Twin Audio provides rear seat occupants with the opportunity to listen to a different audio source than the one selected by the driver on the Infotainment system.

Only an audio source that is not currently active on the radio system can be controlled using Twin Audio.

Two headphone connections are available, with separate volume controls.

Further information is available in the Infotainment system operating instructions.

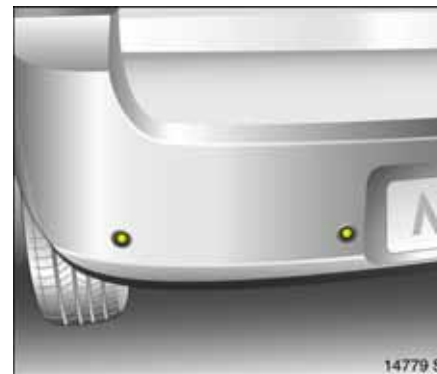

Parking distance sensors *

When reverse gear is selected, the parking distance sensors switch on automatically.

If the vehicle approaches an obstacle when reversing, a series of signals can be heard in the vehicle interior. The interval between the signals becomes shorter as the distance is reduced. If the distance is less than 30 cm, the signal will be continuous.

► Parking distance sensors * – see page 153.

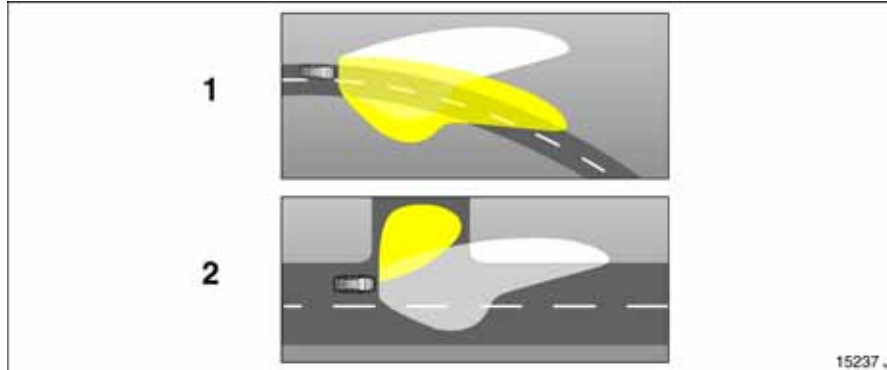

Adaptive Forward Lighting (AFL) *

AFL improves illumination of:

- Curves (curve lighting),
- Intersections and tight turns (turn lighting).

Curve lighting (1)

The light beam pivots based on steering wheel position and speed (from approx. 6 mph (10 km/h)).

The headlights shine at an angle of up to 15° to the right or left of the direction of travel.

Turn lighting (2)

An additional light illuminates at certain steering wheel settings (after rotation of approx. 90°), turn signal settings and speeds (up to approx. 25 mph (40 km/h)).

The light beam projects at a 90° angle to the left or right of the vehicle up to a distance of approx. 30 metres.

Reverse function

Turning the lights on, selecting reverse gear selected and switching on a turn signal light causes the turn lighting to be switched on for the respective side.

When the turn signal is switched off, the turn lighting continues to illuminate for approx. 15 seconds.

► Adaptive Forward Lighting (AFL) * – see page 109.

Keys, Doors, Windows

Replacement keys	26
Lock cylinders	26
Car Pass.....	26
Key with retractable key blade *	26
Electronic immobiliser.....	27
Radio frequency remote control	28
Central locking system	30
Fault when locking or unlocking.....	32
Luggage compartment	32
Vauxhall alarm system *.....	34
Child safety locks	36
Exterior mirrors.....	37
Interior mirror	38
Door windows	39
Electric windows *.....	39
Sunroof and tilting roof *	41

Replacement keys

The key number is specified in the vehicle documents and in the Car Pass *.

The key is a constituent of the electronic immobiliser. Ordering keys from a Vauxhall Authorised Repairer guarantees problem-free operation of the electronic immobiliser.

Keep the spare key in a safe place.

Locks, see page 204.

Lock cylinders

Designed to free-wheel if they are forcefully rotated without the correct key or if the correct key is not fully inserted.

To reset, turn cylinder with the correct key until its slot is vertical, remove key and then re-insert it. If the cylinder still free-wheels, turn the key through 180° and repeat operation.

Car Pass

The Car Pass contains all of the vehicle's data and should therefore not be kept in the vehicle.

Have your Car Pass to hand when consulting a Vauxhall Authorised Repairer.



Key with retractable key blade *

Press button to extend. Press button to retract and audibly engage key blade.

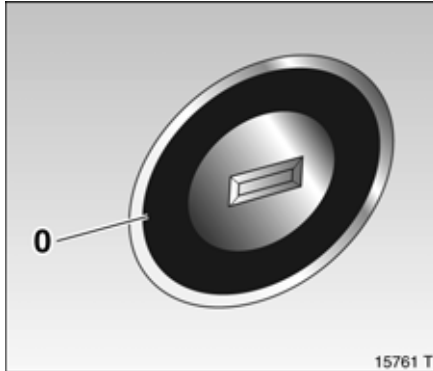

Electronic immobiliser

Using a transponder housed in the key, the system checks whether the vehicle may be started using the key that has been inserted. If the key is recognised as "authorised" the engine can be started.

The electronic immobiliser activates automatically when the key is removed from the starter switch.

The code number of the electronic immobiliser is given in the Car Pass.



Control indicator for immobiliser

Control indicator illuminates briefly when the ignition is switched on.

If the control indicator flashes when the ignition is on, there is a fault in the system; the engine cannot be started. Switch off the ignition and then repeat the start attempt.

If the control indicator continues to flash, try to start the engine using the spare key and contact a workshop for assistance.

If control indicator illuminates after the engine is started, there is a fault in the engine electronics or transmission electronics, or there is water in the diesel fuel filter.

Note

The immobiliser does not lock the doors. Therefore, always lock the vehicle before leaving it unattended and enable Vauxhall alarm system. See page 34.

Radio frequency remote control

Depending on equipment level, the vehicle comes equipped with one of the remote controls illustrated on this page.

The radio frequency remote control is integrated in the key.

Used to operate:

- Central locking system,
- Mechanical anti-theft locking system,
- Vauxhall alarm system ✱.

In vehicles with electric windows in all doors ✱, the remote control can be used to close the windows.

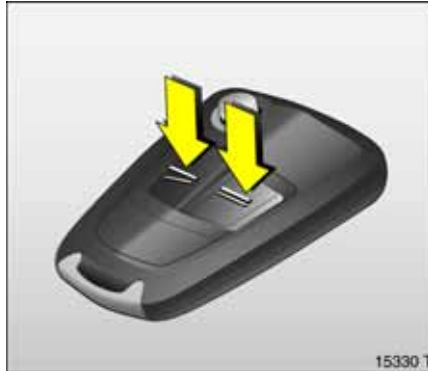

The remote control has a range of approx. 5 metres. This range can be affected by outside influences. Aim the remote control at the vehicle to operate.

Handle the remote control with care, protect it from moisture and high temperatures and avoid unnecessary operation.

The hazard warning lights flash to indicate that the remote control is operational.



Central locking system,
see page 30.

Mechanical anti-theft locking system,
see page 28.

Vauxhall alarm system ✱,
see page 34.

Electric windows ✱,
see page 39.

Fault

If the central locking system cannot be operated with the remote control, it may be due to the following:

- The range of the remote control has been exceeded.
- Remote control battery voltage is too low. Battery replacement - see next column.
- If the remote control is frequently and repeatedly operated outside the reception range of the vehicle (e.g. too far from vehicle), the remote control will no longer be recognised. Remote control synchronisation, see end column.
- If the central locking system is overloaded as a result of repeated operation at short intervals. The power supply is cut off for a brief period.
- Interference from higher-power radio waves from other sources.

To eliminate the cause of a fault, we recommend contacting a workshop for assistance.

Open driver's door with key, see page 32.

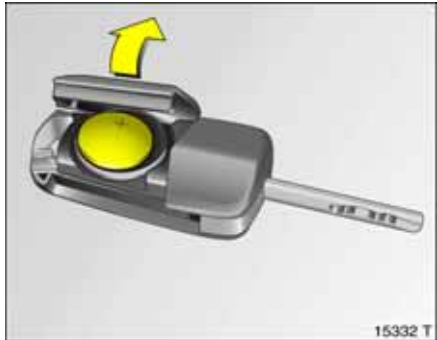

Remote control battery replacement

Replace the battery as soon as the range of the remote control becomes reduced.

Key with retractable key blade, see Fig. 15330 T on previous page.

Extend key, see page 26. Open remote control. Replace battery - battery type, see page 218 - noting installation position. Close remote control.

Make sure that you dispose of old batteries in accordance with environmental protection regulations.

Key with fixed blade, see Fig. 15331 T on previous page.

Have the workshop change the battery.

In the event of a functionality problem or battery replacement, synchronise the remote control.

After changing the battery, unlock the door using the key in the driver's lock cylinder, see page 32. The remote control is synchronised by inserting the key in the starter switch.



Central locking system

For doors, luggage compartment and tank flap.

To unlock

Press button  on the remote control

– or, from the inside –

pull up lock button on driver's door.

When the mechanical anti-theft locking system is enabled, the doors cannot be unlocked by pulling up the lock buttons.

Country-specific version *:

Pressing once unlocks the driver's door, and pressing twice unlocks the entire vehicle.



To lock

Close doors, luggage compartment and tank flap.

Press button  on the remote control

– or, from the inside –

press lock button on driver's door when the doors are closed.

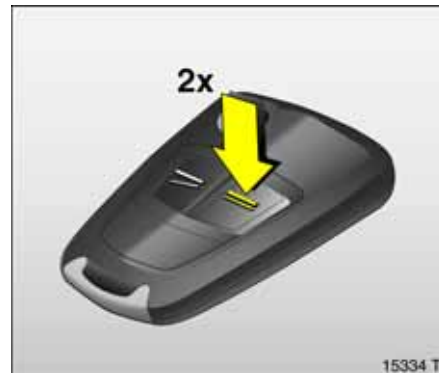

Mechanical anti-theft locking system

Warning

Do not use the system if there are people in the vehicle! The doors cannot be unlocked from inside.

All the doors must be closed.

Press the  button on the remote control within 10 seconds of locking.

Lock buttons on all doors are positioned such that doors cannot be opened.

If the ignition was on, the driver's door must be opened and closed once so that the vehicle can be secured.

Note

- To prevent the driver from being inadvertently locked out, the button on the driver's door cannot be depressed when the door is open.
- If the driver's door is not closed properly, the central locking system will unlock again immediately after locking.
- Approx. 30 seconds after unlocking using the remote control, the doors lock again automatically if no door is opened.
- To lock the doors from inside (e.g. to prevent unwanted entry from outside), press lock button on driver's door when the doors are closed.
- Locked doors unlock automatically if an accident of a certain severity occurs (to permit outside assistance). Prerequisite: Ignition must not be switched off.

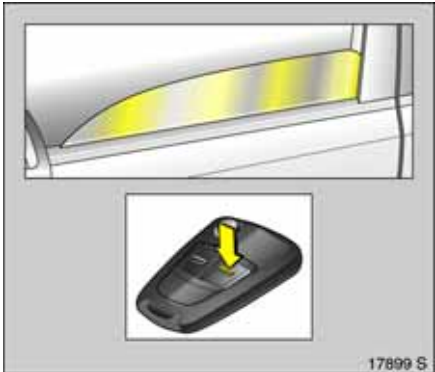

Closing windows ✳ from outside

Warning

Exercise care when operating electric windows. Risk of injury, especially for children.

Vehicle passengers must be informed accordingly.

Keep a close watch on the windows when closing them. Ensure that nothing becomes trapped in them as they move.

On vehicles with electric windows in all doors ✳, the windows can be closed from outside:

Hold button = on the remote control depressed until all of the windows have closed completely.

Further information on electric windows, see page 39.

Fault

If the central locking cannot be operated, this can be for one of the following reasons:

- If the central locking system is overloaded as a result of repeated operation at short intervals. The power supply is cut off for a brief period.
- Defective fuse in fusebox, see page 188.

To eliminate the cause of a fault, we recommend contacting a workshop for assistance.

Operate driver's door with key, see next page.



Fault when locking or unlocking

Fault in remote control

To unlock

Turn key clockwise in driver's door lock, return to the vertical position and remove. The entire vehicle is unlocked. Switch on the ignition to deactivate the Vauxhall alarm system *.

To lock

With the driver's door closed, turn the key anticlockwise in the lock, return to the vertical position and remove. The entire vehicle is locked.

Malfunction in central locking system

To unlock

Turn key clockwise in driver's door lock, return to the vertical position and remove. The driver's door is unlocked. The other doors can be unlocked by pulling up the interior lock buttons (not possible if the mechanical anti-theft locking system is enabled). Switch on the ignition to deactivate the Vauxhall alarm system *.

To lock

With the driver's door open, press the interior lock button of the other doors. Close the driver's door. Turn the key anticlockwise in the lock, return to the vertical position and remove. The tank flap cannot be locked if there is a malfunction in the central locking system.

Note

- The mechanical anti-theft locking system and the Vauxhall alarm system * cannot be activated with the key.
- To deactivate the Vauxhall alarm system * after opening a door, switch on the ignition.
- To eliminate the cause of a fault, we recommend contacting a workshop for assistance.



Luggage compartment

To unlock

Press button  on the remote control. The luggage compartment is unlocked together with the doors and the tank flap.

Country-specific version *:

Press button  twice on the remote control; one press unlocks the driver's door, two presses unlocks the entire vehicle.

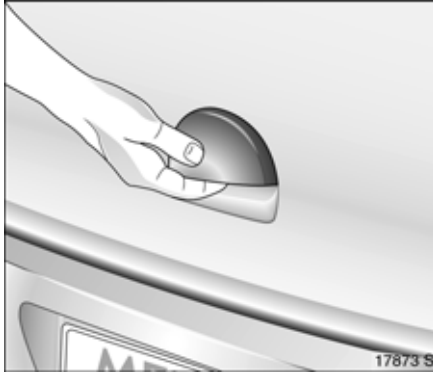
**To open**

The luggage compartment is opened by operating the unlocking button beneath the handle.

⚠ Warning

Do not drive with the luggage compartment open or ajar, e.g. when transporting bulky objects, since toxic exhaust gas could penetrate the interior.

Fitting of accessories on the tailgate will increase its weight. If it becomes too heavy, it will then not stay open.

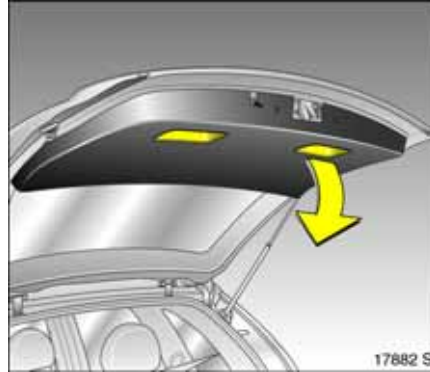
**To close**

There are two handles on the inside of the tailgate for closing the luggage compartment.

Do not operate the unlocking button beneath the handle when closing. Otherwise the luggage compartment will once again be unlocked.

**To lock**

Press button = on remote control.

Vauxhall alarm system *

Monitors:

- The doors, luggage compartment, bonnet,
- The passenger compartment,
- Vehicle tilt, e.g. if it is raised,
- The ignition.



To activate

All doors, windows, sunroof *, tilting roof * and the bonnet must be closed.

Press button  on the remote control to activate the Vauxhall alarm system and lock the doors.

If the ignition was switched on, the driver's door must be opened and closed once so that the anti-theft alarm system can be switched on.

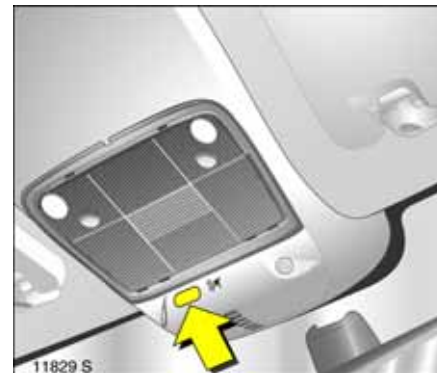

Activation without monitoring of passenger compartment or vehicle tilt
E.g., if animals are to be left in the vehicle.

1. Close luggage compartment and bonnet.
2. Press button in front of the courtesy light (with ignition off); LED in the hazard warning light button flashes for a maximum of 10 seconds.
3. Close doors.
4. Switch on anti-theft alarm system. LED illuminates. After approx. 10 seconds, the anti-theft alarm system is activated without monitoring of the passenger compartment or vehicle tilt. The LED flashes until the system is switched off.

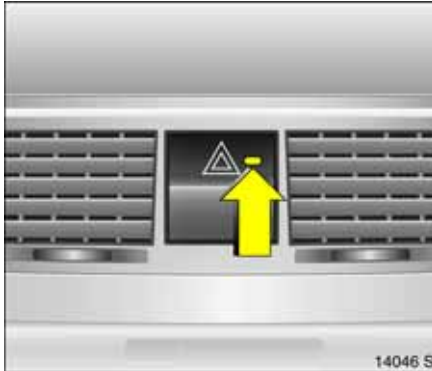

Light emitting diode (LED)

During the first 10 seconds of anti-theft alarm system activation:

- LED comes on = Test, switch-on delay,
- LED flashes quickly = Door, luggage compartment or bonnet open, or system fault.

After the first 10 seconds of anti-theft alarm system activation:

- LED flashes slowly = System switched on,
- LED illuminates for approx. 1 second = Switch-off function.

If a system fault occurs, contact a workshop for assistance.



To deactivate

Press button  on remote control unit – or – turn on ignition.

If there is a fault in the remote control, unlock vehicle as described on page 32.

If the alarm is triggered when the driver's door is opened, deactivate the anti-theft alarm system by switching on the ignition.

Note

■ Changes to the vehicle interior, such as the use of seat covers, could impair the function of passenger compartment monitoring.

Alarm

An alarm can be triggered when the anti-theft alarm system is switched on, indicated by:

- An acoustic signal (horn) and
- A visual signal (hazard warning lights).

The number of alarms and the duration thereof are stipulated by law.

The alarm can be silenced by pressing button  on the remote control or by switching on the ignition. The anti-theft alarm system is deactivated at the same time.

Alarm siren with integrated battery*

The alarm siren monitors the on-board voltage network and triggers an alarm if this network is manipulated (e.g. if the vehicle's battery is disconnected by unauthorised persons). The alarm siren has its own power supply and is therefore not dependent on the vehicle's battery.

If the vehicle's battery is to be disconnected (e.g. for maintenance work), the alarm siren must be deactivated as follows: switch the ignition on then off, disconnect the vehicle's battery within 15 seconds.

To switch off alarm siren:
Switch ignition on then off.



Child safety locks

 **Warning**

Use the child safety lock whenever children are occupying the rear seats. Disregard of these instructions may lead to injuries or endanger life. Vehicle passengers must be informed accordingly.

Turn rotary knob in each rear door lock from vertical position using the ignition key: Door cannot be opened from the inside.



Exterior mirrors

Manual

From the inside, move the handle in the appropriate direction.



Electric ✱

Four-way switch in driver's door.

Move rocker switch located above the four-way switch to the left or right: Four-way switch controls corresponding mirror.

Aspherical exterior mirror ✱

Increases the field of view. Estimating the distance away from vehicles following you is only possible to a limited extent because of slight distortion.



Swing-in exterior mirrors

Manually: Press lightly.

Electrically: Press button. The mirrors swing-in to their respective end positions. If a mirror has been manually adjusted, swing-in both mirrors by hand and then press the button.

After electrical operation, there is a 6-second delay before the mirrors can be operated again.

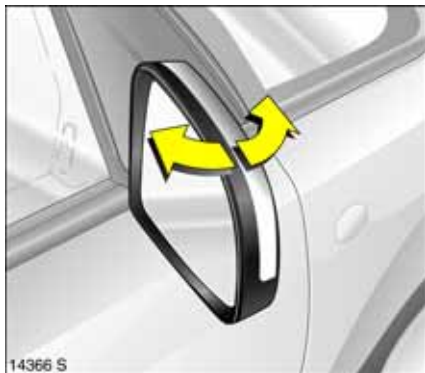

For the safety of pedestrians, the exterior mirrors will swing out of their normal mounting position if they are bumped with sufficient force. Reposition the mirror by applying slight pressure to the mirror housing.



Interior mirror

To adjust, swivel mirror housing.

Swivel lever on underside of mirror housing to reduce dazzle at night.



Automatic anti-dazzle interior mirror*
Dazzle at night is automatically reduced.

The mirror does not reduce dazzle when:

- The ignition is switched off,
- Reverse gear is engaged or the selector lever is set to **R**,
- Interior lighting has been switched on.

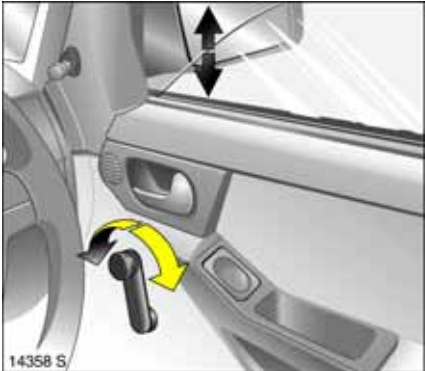

Door windows

The door windows can be operated with the crank.

Electric windows *

⚠ Warning
<p>Take care when operating the electric windows *. Risk of injury, especially for children. Inform vehicle occupants.</p> <p>If there are children occupying the rear seats, switch on child safety system for rear windows *, see next page.</p> <p>Keep a close watch on the windows when closing them. Ensure that nothing becomes trapped in them as they move.</p>

Operable when the ignition key is in position 1 (see page 9).

Button illumination indicates operational readiness.

Operational readiness ends when the driver's door is opened.

Operated with two or four cross switches in driver's door armrest: top cross switches for driver's and front passenger's door windows, and bottom cross switches * for the rear windows.

There are also cross switches in the front passenger's door arm rest and in the rear door armrests *.



To operate window in stages, tap appropriate switch.

For automatic opening or closing, keep switch pressed for slightly longer.

To stop window movement, tap switch again.

Safety function

If the window glass encounters resistance above the middle of the window during automatic closing, it is immediately stopped and the window opened again.

If the windows do not move easily (e.g. on account of frost), repeatedly tap the switch for the appropriate window until the window has been closed in stages.

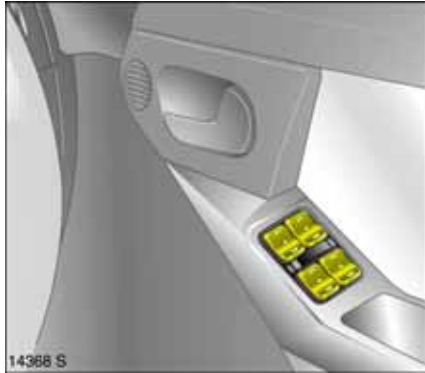

Child safety system for rear windows *

Switch between the rocker switches in the armrest on the driver's door:

- To the left (red control indicator visible): Rear windows cannot be operated with the rocker buttons in the rear doors,
- To the right (green control indicator visible): Rear windows can be operated with the rocker buttons in the rear doors.

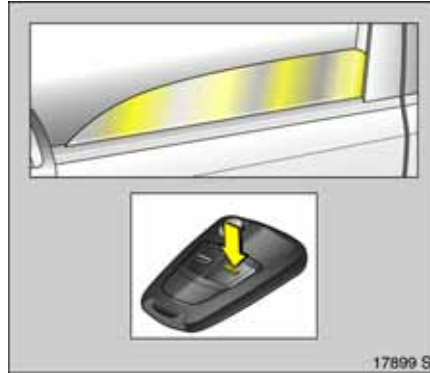

Closing windows from outside *

On vehicles with electric windows in all doors, the windows can be closed from outside:

Hold button  on the remote control until all of the windows have closed completely.

Overload

If the windows are repeatedly operated at short intervals, the power supply is briefly cut off.

The system is protected by fuses in the fusebox, see page 186.

Fault

The windows cannot be automatically opened or closed.

Activate electric windows as follows:

1. Close doors.
2. Switch on ignition.
3. Open window completely.
4. Close window and hold down rocker switch for at least another 5 seconds.
5. Repeat for each window.



Sunroof and tilting roof *

⚠ Warning

Take care when operating sunroof * and tilting roof *. Risk of injury, especially for children. Vehicle occupants must be informed accordingly.

Keep a close watch on the sliding roof when closing it. Ensure that nothing becomes trapped in it as it moves.

Front sliding roof

Left rocker switch ☑ and ⚡ between the sunvisors. Operable when the ignition is on.

To open:

Press button ☑, sunroof opens.
To stop the movement, press button again.

To close

Press button ⚡ until the sunroof is closed.

To raise

With the sunroof closed, press button ⚡ until sunroof is open.

To lower

Press button ☑ until the sunroof is closed.



Rear tilting roof

Right rocker switch ⚡ and ⚡ between the sunvisors. Operable when the ignition is on.

To raise

Press button ⚡ until tilting roof has been raised.

To lower

Press button ⚡ until tilting roof has closed.

Sunshade

To reduce the sunlight in the vehicle interior with the sliding roof closed or raised.

Open or close sunshade as required.

When the sunroof is opened, the sunshade is also opened.

Note

- If the top of the roof is wet, raise roof, allow water to run off and then open roof.
- When using a roof rack, check the clearance of the sunroof, to avoid damage.



Fault

If the electric drive fails, the system is protected by a fuse in the fusebox – see page 186. Until the fault is remedied, operate the sunroof as follows:

Push drive cover backwards.



Press the sprung central part of the drive shaft in as far as possible with a screwdriver * and turn the driveshaft until the sunroof or tilting roof is closed.

Seats, Interior

- Front seats 43
- Head restraints 45
- Armrest * 47
- Travel Assistant * 47
- Rear seats..... 50
- Flexible Seat System (FlexSpace)..... 51
- Luggage compartment extension 52
- Luggage compartment cover *..... 54
- Safety net * 55
- Lashing eyes * 56
- Bag hangers * 56
- Notes on loading the vehicle 56
- Three-stage safety system..... 58
- Three-point seat belts 58
- Belt tensioners..... 60
- Using the belts 62
- Mounting brackets * for ISO-FIX child restraint systems 64
- Child restraint systems * 65
- Airbag system 67
- Cigarette lighter * 79
- Accessory sockets * 79
- Ashtrays 80
- Foldaway tables * 82
- Stowage compartments..... 81
- Coin holder 83
- Sunvisors..... 83

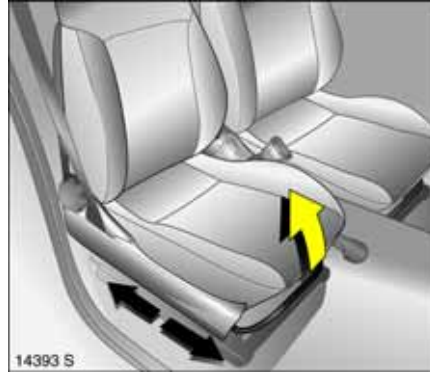

Front seats

Warning

Important: Do not sit nearer than 10 inches (25 cm) from the steering wheel, to permit safe airbag deployment. Never adjust the seat while driving. It could move in an uncontrolled manner when the handle is pulled.

Adjust seat longitudinally

To adjust, pull the handle on the front seat, slide the seat and release the handle.



Adjusting the backrest

To adjust, turn handwheel on outboard side of seat while releasing the load on the backrest.

Move seat backrest to suit seating position.

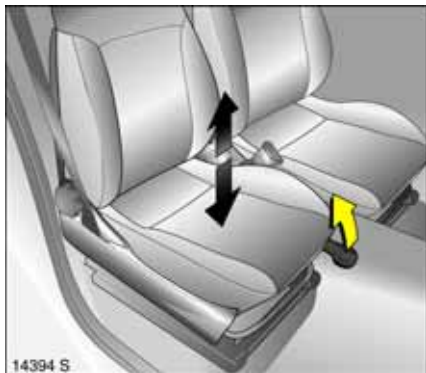

Adjusting the seat height

To adjust, pull lever up and relieve the load on the seat cushion, or press the seat cushion down with your body weight.

Never adjust driver's seat height while the vehicle is in motion. Uncontrolled adjustments could occur when the lever is pulled.

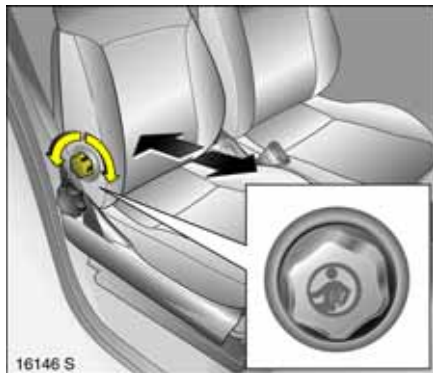

Adjusting the lumbar support *

To adjust, turn side handwheel on outboard side of seat while relieving the load on the backrest.

Adjust lumbar support to suit personal requirements.



Seat position

Adjust driver's seat such that with the driver sitting upright, the steering wheel is held in the area of its upper spokes with the driver's arms slightly bent.

Push front passenger's seat as far back as possible.

The seat backrests must not be tilted too far back. Recommended maximum tilting angle approx. 25°.

Warning

Failure to observe these descriptions could lead to injuries which could be fatal. Vehicle passengers must be informed accordingly before starting-off.



Head restraints

Adjusting the front head restraints and the rear outboard head restraints *

To adjust head restraint, tilt forward, hold and adjust height.

To fold over the rear seats or lower the front passenger's seat head restraint all the way down and remove, see next page.

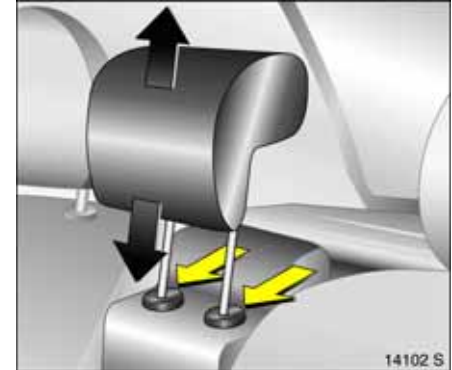

Adjusting the rear centre head restraint

To adjust, pull head restraint upwards, press springs and push head restraint down.

To improve visibility, push head restraint down as far as possible if centre seat is unoccupied or to increase the size of the luggage compartment.

Fold centre seat – see page 53.

If centre seat is occupied, pull head restraint upwards.



Head restraint position

The middle of the head restraint should be at eye level. If this is not possible for extremely tall persons, set to highest position, and set to lowest position for small persons.

⚠ Warning

Failure to observe the descriptions can lead to injuries which could be fatal. Vehicle passengers must be informed accordingly before moving away.

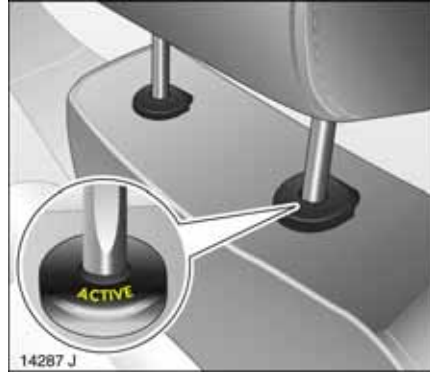

Active head restraints *

In the event of a rear-end impact, the active head restraints automatically tilt forward a little. The head is more effectively supported by the head restraint and the danger of injuries caused by whiplash in the neck area is reduced.

Active head restraints are identified by the lettering **ACTIVE** on the head restraint guide sleeves.

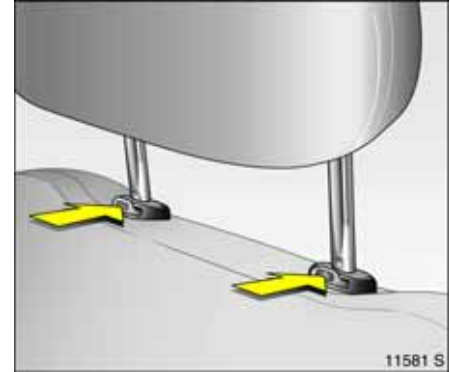

Removing the head restraints

Press and release the two catches. Pull and remove the head restraint.

Note

Only approved objects or components should be attached to the head restraint of the unoccupied front passenger's seat.



Armrest*

Armrest at driver's seat

Push raised armrest backwards against resistance and fold down.

The armrest can be moved to different positions in stages by lifting it.

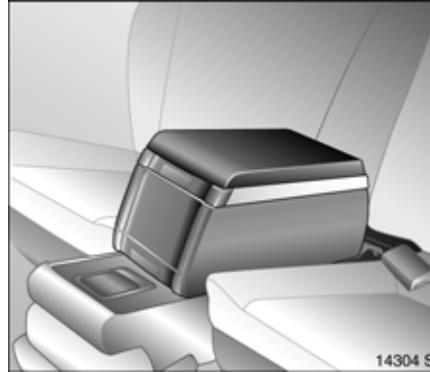

Travel Assistant*

The Travel Assistant contains:

- Armrest,
- Tray,
- Drink holders.

The Travel Assistant is mounted on the lowered centre seat (see page 53).

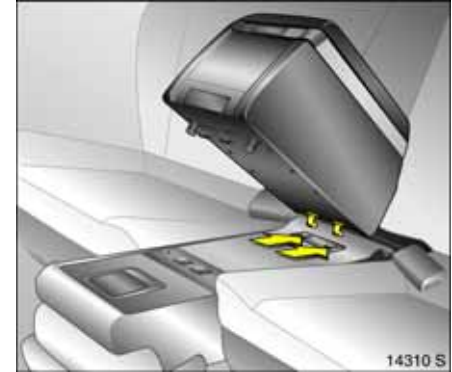

Installing The Travel Assistant

Lower the centre seat – see page 53.

Insert Travel Assistant in rear recesses on back of centre seat.

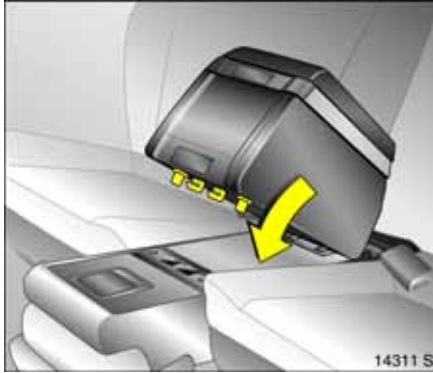

Fold Travel Assistant down and audibly engage in front recesses.

⚠ Warning

If it is not correctly engaged, the Travel Assistant can be propelled forward with considerable force if hard braking occurs, possibly causing injury.

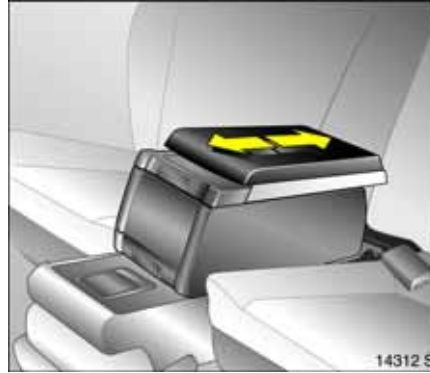

Armrest

The armrest can be moved and therefore adapted to the position of the outboard seats.

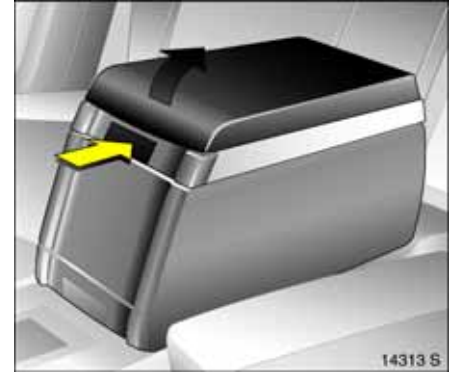

Tray

There is a tray beneath the armrest. Open tray by pushing upper button.

**Drink holders**

Open drink holder on front by pressing front face.

**Dismantling the Travel Assistant**

Press lower button on the Travel Assistant.



Pull Travel Assistant upwards out of recesses.

There is a carrying handle on the back to facilitate transport.

It is not necessary to remove the Travel Assistant if you wish to raise the centre seat, however, the armrest must be pushed forwards. Be careful of any items in the Travel Assistant.

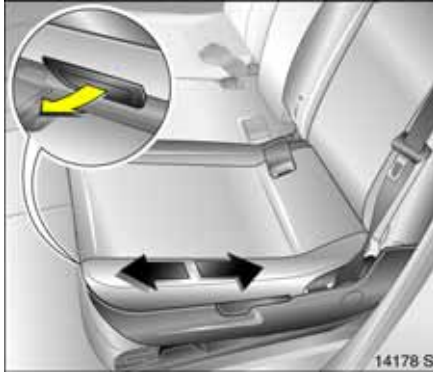

Rear seats

Move rear outboard seats

Pull handle under seat, move seat, release handle and allow seat to engage.

The backrests must not be in the rearmost position when the seats are moved back, in order to prevent damage.



Adjusting backrests of rear outboard seats

Get hold of backrest, pull handle at outboard side of seat and guide backrest into the relevant position. Release handle and allow backrest to engage.

The seat backrest engages in several positions.

Warning

To prevent injuries, always hold seat backrest firmly and guide downwards when folding.

To extend the luggage compartment, the seat can be swivelled down. However, we recommend always using the seat for sitting only when in the swivelled-up position. To extend the luggage compartment, see page 52.

Flexible Seat System (FlexSpace)

In the rear row of seats, your vehicle offers either three seats or two seats with more seating room, in this case the centre seat must be folded down. The outboard seat backrests can be swivelled downwards to increase the size of the luggage compartment.



Two rear seats with more seating space

Lower centre seat – see page 53.

Move backrest to centre position, pull handle beneath seat, slide seat backwards as far as possible, then slide inwards to centre of vehicle and further back into the desired position.

Release handle and allow seat to engage in position.

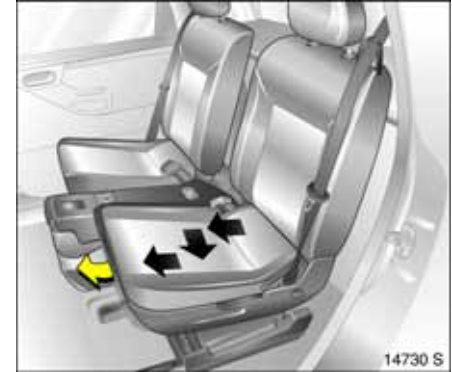

Three seats

Move backrest to centre position, pull handle beneath seat, slide seat forwards to the stop, then slide out towards door and further forward into the desired position.

Release handle and allow seat to engage in position.

Raise centre seat – see page 53.

Luggage compartment extension

To increase the size of the luggage compartment, you can:

- Fold down the outboard rear seat backrests,
- Lower the centre seat,
- Swivel down the outboard seats,
- Fold down the front passenger's seat backrest*.

See following pages for instructions.

The rear seats must be in the outboard positions, see "Three seats" on the previous page.

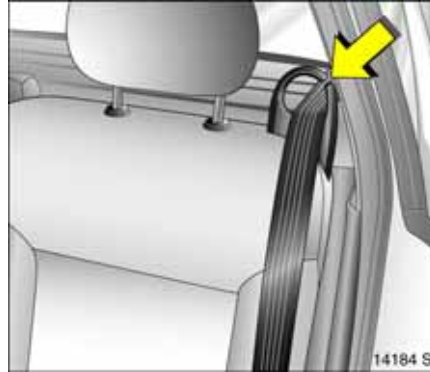

Fold down outboard rear seat backrest

If necessary, remove luggage compartment cover* – see page 54.

Push head restraints down fully - see pages 4, 45.

Take seat belt out of the belt guide on the backrest.

Remove the push-in sleeves* for mounting the ISO-FIX child restraint system – see separate instructions for the ISO-FIX child restraint system.

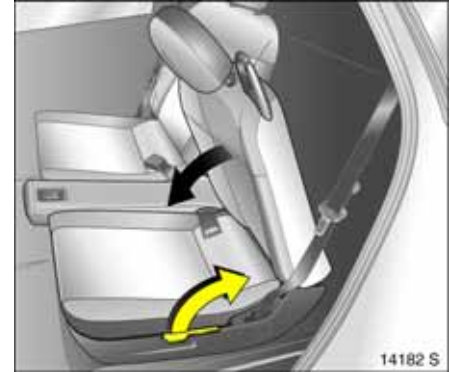

Hold the backrest, pull handle at outboard side of seat and fold backrest down onto seat cushion. Release handle and engage backrest.

Warning

To prevent injuries, always hold seat backrest firmly and guide downwards when folding.

To raise, pull handle on outboard side of the seat and raise seat backrest. Release handle and latch.

Insert seat belt into belt guide on backrest.

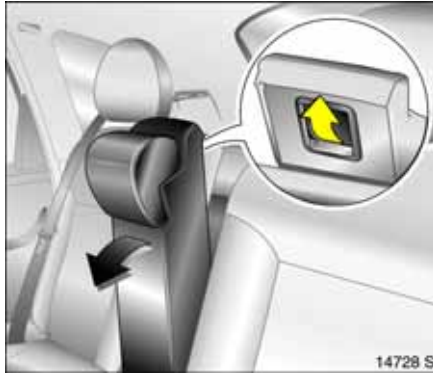

Lower centre seat

House centre seat belt in the holder in the roof – see page 63.

Insert seat belts into recesses in seat cushions.

Push centre head restraint as far down as it will go – see page 45.

Pull release handle at rear of centre backrest – see illustration. Tilt backrest forward and engage.

⚠ Warning

Loads must not obstruct the operation of the handbrake and the gears. Pay attention to notes on page 56.

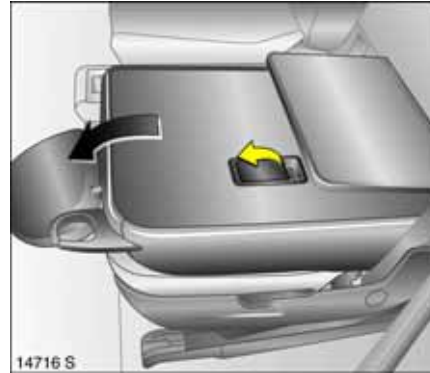

Raise centre seat

Pull release handle, move backrest upright and engage. Outboard seats must be in the outer position to do this – see right-hand column on page 51.

Folding down outboard seats

Push front seats forwards or remove head restraints on the rear outboard seats – see page 46.

Fold down outboard rear seat backrests.

To achieve a level loading surface, pull release handle on back of backrest and push seat down until it latches into position.

Raise outboard seats

Pull release handle on back of backrest and pull seat upwards until it engages.

Pull handle on outboard side of rear seat and move rear seat backrest upright. Release handle and latch into position.

Insert seat belt into belt guide on backrest.

The seat backrests can be righted even with the seat swivelled back. We recommend only using the seat for sitting while in the swivelled-up position.

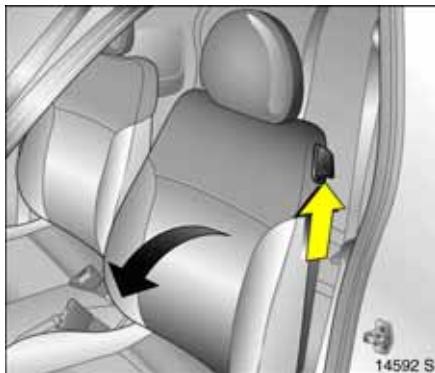

Folding down the front passenger's seat *

Push front passenger's seat head restraint all the way down or remove – see pages 4, 45, 46.

Push front passenger's seat backwards.
Raise release lever and fold front passenger's seat forwards.

Raise front passenger's seat backrest *

Raise release lever, lift front passenger's seat and audibly engage backrest into position.

Notes on loading

See page 56.

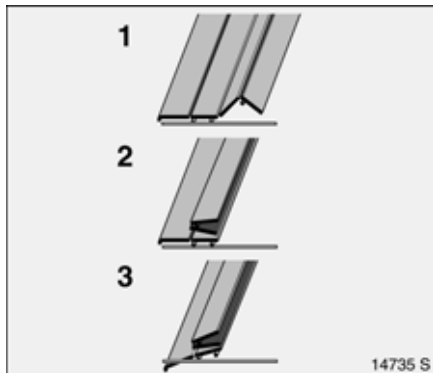

Luggage compartment cover *

To open:

Lift cover at rear and tilt forwards, segment by segment.

To close:

Tilt top part of cover backwards and latch into position.

Do not place any heavy or sharp-edged objects on the cover.

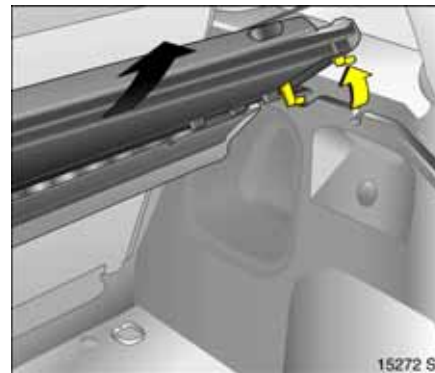

Removing

Open cover, disengage towards the rear and remove from above.

Fitting

Insert the cover from the rear, clip into place and fold back.

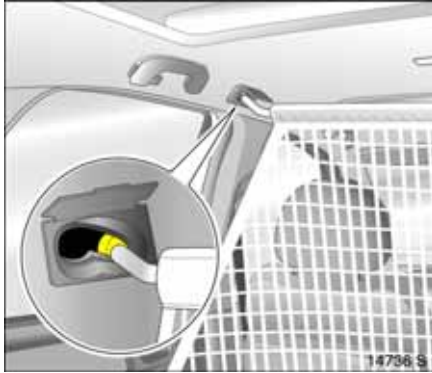

Safety net *

The safety net is installed behind the front seats with the rear seat backrests folded forward.

Passengers must not be carried behind the safety net.

Fitting

Fold all rear seat backrests forwards – see luggage compartment extension, page 52.

The roof frame contains two mounting openings: Open covers.

Hang the upper net rod first in one aperture and then in the other side; clip in place by pushing rod forwards into smaller aperture.

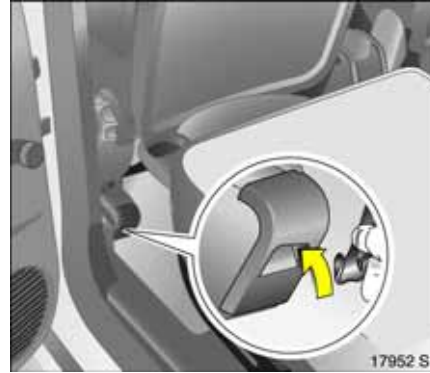

Hook tension straps into lashing eyes * or slots * at the rear of the outer front seat bracket and tension.

On the version without lashing eyes, when the safety net is mounted for the first time, the slots at the rear of the outer front seat bracket must first be opened:

Press the marked field at the upper edge with a blunt object and fold inwards.

Removing

Tilt belt length adjuster upwards and unhook belts. Unhook top net rods and close two mounting openings.

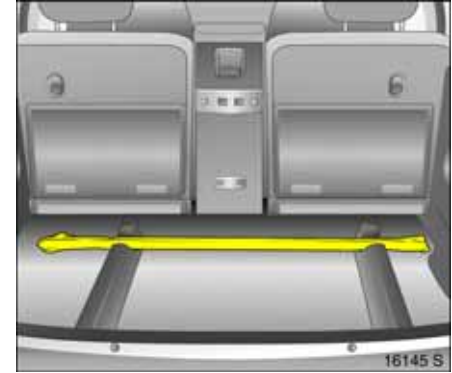

Stowage of safety net

Roll up the removed safety net and secure it with Velcro strips.

Store the safety net under the floor in the luggage compartment. To open, remove the luggage compartment cover *, see page 54, lift the floor covering by the handle and raise towards the front, see page 176. Store safety net in front recesses.



Lashing eyes *

The lashing eyes in the luggage compartment are for securing transported items to prevent them from slipping around.

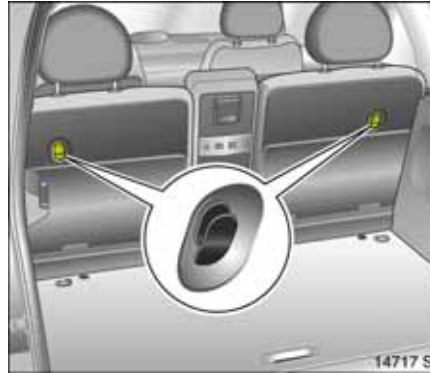

Bag hangers *

There are two retainers on the back of the outer rear seat backrests for hanging carrier bags on. Maximum load: 10 kg per retainer.



Notes on loading the vehicle

- Heavy objects in the luggage compartment should be placed as far forward as possible against the engaged rear seat backrests or, if the rear seat backrests are folded down, against the front seat backrests. If objects are to be stacked, the heavier objects should be placed at the bottom. Unsecured objects in the luggage compartment would be thrown forward with great force in the event of heavy braking, for example.

- Secure heavy objects with lashing straps * attached to lashing eyes * – see page 56. If heavy loads slip when the vehicle is braked heavily or driven around a bend, the handling of the vehicle may change.
- When transporting objects with rear seat backrests tilted forward, fit safety net – see page 55.
- Close the luggage compartment cover * so the rear window does not reflect the objects.
- If the backrests are not folded down when transporting objects in the luggage compartment, they must be engaged in an upright position - see page 53.

- Do not allow the load to protrude above the upper edge of the rear seat backrests, or above the upper edge of the front seat backrests if the rear seat backrests are folded down.
- The warning triangle * and first-aid kit (cushion) * must always be freely accessible.
- Do not place any objects in front of the rear window or on the instrument panel. They are reflected in the glass, obstruct the driver's view and will be thrown through the vehicle, for instance in the event of heavy braking.
- Objects must not be stored in the airbag inflation area, because they could cause injury if the airbag inflates.

- Loads must not obstruct the operation of the pedals, the handbrake or the gears, or restrict the driver's freedom of movement. Do not place loose objects in the vehicle interior.
- Do not drive with luggage compartment open when transporting bulky objects, for example, since toxic exhaust fumes could penetrate the interior.
- Weights, payload and roof load – see page 214.
- A roof load increases the sensitivity of the vehicle to crosswinds and impairs vehicle handling due to the vehicle's higher centre of gravity. Driving with a roof load - see pages 138, 141, 163.

 Warning

Failure to observe these descriptions can lead to injuries which may be fatal. Vehicle passengers must be informed accordingly.

Three-stage safety system

Comprising:

- Three-point seat belts,
- Belt tensioners at the front seats,
- Airbag systems for the driver's seat and front passenger's seat * as well as the outboard rear seats *.

The three stages are activated in sequence depending on the severity of the accident:

- The automatic seat belt locking devices prevent the belt strap from being pulled out and thus ensure that the vehicle occupants are retained in their seats.
- The front seat belts are pulled down at the belt buckles. This means the belts fit snugly, the occupants are decelerated early with the vehicle and the stress placed on the body is reduced.
- The airbag systems are also triggered in the event of severe accidents and form a safety cushion for the occupants.

Warning

The airbag systems serve to supplement the three-point seat belts and belt tensioners. The seat belts must therefore always be worn. Disregard of these instructions may lead to injuries or endanger life. Vehicle passengers must be informed accordingly.

Always read the instructions provided with the child restraint system!



Three-point seat belts

The vehicle is equipped with three-point seat belts with automatic retractors and locking devices, allowing freedom of body movement although the spring tensioned belts always ensure a snug fit.

For information on correct seating position – see pages 44, 62, 68.

The belt has a "vehicle sensitive retractor" which is designed to lock during heavy acceleration or deceleration in any direction.

 **Warning**

Always wear your seat belt, and that means also in urban traffic and when you are a rear seat passenger. It can save your life!

Also, pregnant women must always wear a seat belt – see page 62.

In the event of an accident, persons not wearing seat belts endanger their fellow occupants and themselves.

Control indicator  for the seat belt – see page 84.

Seat belts are designed to be used by only one person at a time. They are not suitable for anyone under 12 years of age or 150 cm.

For children up to 12 years of age, we recommend the Vauxhall child restraint system – see page 65.

Belt force limiters

Belt force limiters on the front seats reduce the body load, due to damped release of the belt on a collision. This means that the seat occupants move forward under control.

Testing the belts

Check all parts of the belt system periodically for damage and correct functioning. Replace damaged components. After an accident, have the belts and triggered belt tensioners replaced by a workshop.

Do not perform any alterations on the belts, their anchorages, the automatic retractors or the belt buckles.

Make sure that belts are not damaged or trapped by sharp-edged objects.

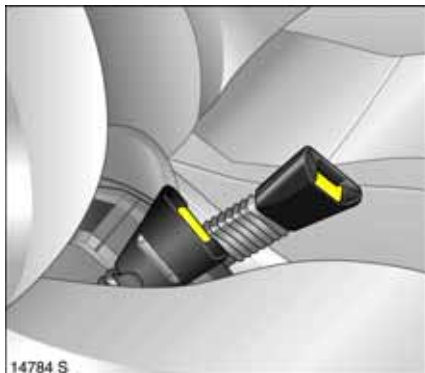

Belt tensioners

The front seat belt systems are equipped with belt tensioners. In the event of a head-on or rear-end collision of a certain severity, the belt buckles are pulled down, thus tightening the belts.

Actuation of belt tensioners

Indicated by illumination of control indicator , see next column.

If the belt tensioners are triggered, they must be replaced by a workshop.



Control indicator for belt tensioners

The function of the belt tensioners and airbag systems is monitored electronically and indicated by the control indicator .

When the ignition is turned on, the control indicator illuminates for approx. 4 seconds. If it does not illuminate, or if it does not go out after 4 seconds, or if it illuminates while driving, there is a fault in the belt tensioner or airbag systems, see page 72. The systems might not trigger in the event of an accident.

Deployment of the belt tensioners is indicated by continuous illumination of .

Warning

Eliminate the cause of the fault immediately by a workshop.

Self-diagnosis integrated into the system allows rapid fault identification.

Important

- Do not fit accessories not specifically released for your vehicle type or store objects in the belt tensioner operating area (in the area of the belt tensioners) due to the risk of injury in the event the belt tensioners are triggered.
- Do not make any modifications to the components of the belt tensioners, as this will render the vehicle unroadworthy.

 **Warning**

Incorrect handling (e.g. removal or fitting of seat belts or belt buckles) can trigger the belt tensioners; risk of injury.

- The belt tensioner and airbag system control electronics can be found in the centre console area. In order to avoid malfunctions, do not store magnetic objects in this area.
- When using the rear seats, ensure that the front seat belt components are not damaged by shoes or other objects. Avoid dirt getting into the belt retractors.
- We recommend that you have the front seats removed by a workshop in the event of actuation of the belt tensioners.
- The belt tensioners trigger once only, indicated by the illumination of control indicator . Have a workshop replace triggered belt tensioners.
- When disposing of the vehicle, the safety instructions given for this must be observed. Take the vehicle to a recycling company for disposal.



Using the belts

Fitting seat belts

Pull the belt out of the retractor and guide it across the body, making certain that it is not twisted.

Insert the latch plate into the buckle. The front seat backrest must not be tilted back too far or the seat belt will not operate properly. The recommended angle of inclination is 25°.

Make sure that the lap belt is not twisted and that it fits snugly across the body. Tension the belt frequently while driving by tugging the diagonal part of the belt.

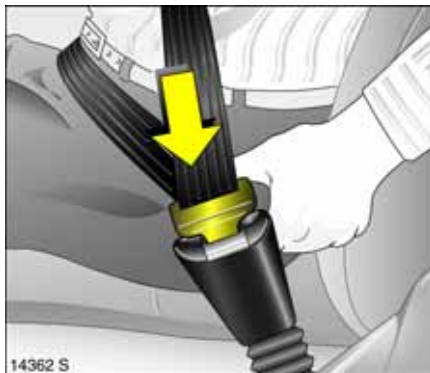

Warning

On pregnant women in particular, the lap belt must be positioned as low as possible across the pelvis so as not to put too much pressure on the abdomen.

Bulky clothing prevents the belt from fitting properly. The belt must not rest against hard or fragile objects in the pockets of your clothing (e.g. ballpoint pens, keys, spectacles) because these could cause injury. Do not place any objects (e.g. handbags, mobile phones) between the belt and your body.

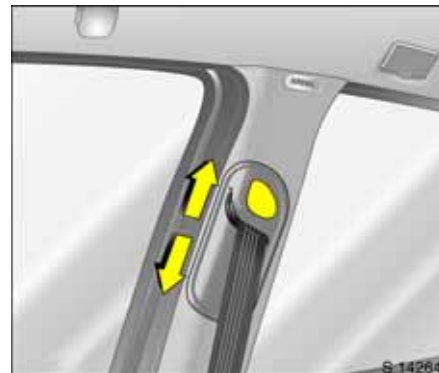

Height adjustment

For height adjustment of the upper guiding point of the front seat belts:

1. Pull belt out slightly.
2. Push button on sliding adjuster.
3. Set desired height.
4. Allow sliding adjuster to audibly latch.

Do not adjust height while driving.



Adjust height such that the belt passes over the wearer's shoulder and rests against the shoulder. It must not pass over the neck or upper arm.



Removing the belt

To remove the belt, depress the red pushbutton on the buckle; the belt will retract automatically.



Three-point seat belt on centre rear seat

Pull latch plates out of belt retainer in roof.

Click bottom latch plate into right-hand buckle (1) on centre seat. Remove top latch plate from retainer, guide over shoulder and lap area with belt (do not twist) and click into left buckle (2) on centre seat.

If using the centre seat, both outboard seats must be pushed backwards and the backrests must be flush with the centre seat backrest, see page 51.



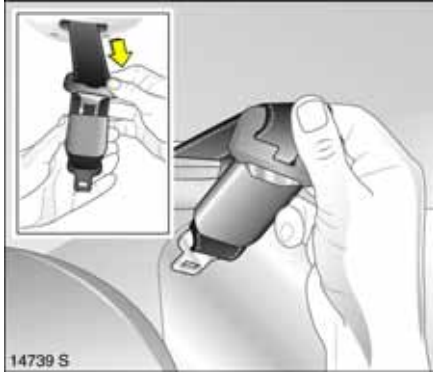

To remove the belt, press the button on the left side of the buckle (2). If the central seat is to be lowered, press the button on the right side of the buckle (1). The belt retracts automatically.

Push the upper latch plate into the holder for the lower latch plate. Fold over locked together latch plates against the belt.

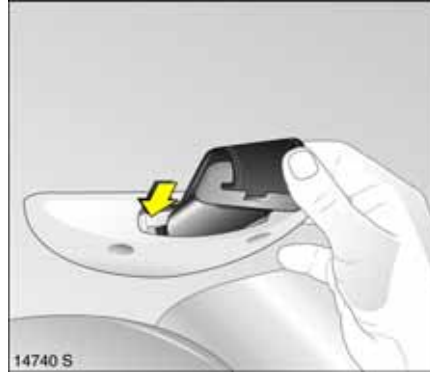

Insert in the belt retainer in the roof with the lower latch plate pointing forwards.

Mounting brackets *for ISO-FIX child restraint systems

The brackets located between the backrest and seat cushion are used for mounting ISO-FIX child restraint systems.

Please follow the instructions accompanying the ISO-FIX child restraint system.

Only ISO-FIX child restraint systems approved for the vehicle may be used.

Child restraint systems *

When using a child restraint system, follow the instructions for installation and use.

The country in which you are travelling may not permit the use of child restraint systems on certain seats. Always comply with the local or national regulations.

Selecting the right system

Your child should travel facing backwards in the vehicle for as long as possible.

A child has a very weak cervical spinal column and in the event of an accident is less likely to suffer injury in a rearward-facing, semi-lying position than if seated upright.

 **Warning**

Never carry child restraint systems on your lap, risk of fatal injury.

Permissible options for fitting a child safety seat¹⁾

Weight and age class²⁾	On front passenger's seat	On outboard rear seats	On centre rear seat
0: up to 10 kg or approx. 10 months	B ¹ , +	U, +	U, ++
0+: up to 13 kg or approx. 2 years			
I: 9 to 18 kg or approx. 8 months to 4 years	B ² , +	U, +	U, ++
II: 15 to 25 kg or approx. 3 to 7 years	X	U	U, ++
III: 22 to 36 kg or approx. 6 to 12 years			

¹⁾ For reasons of safety, we recommend that the child safety seat be installed on one of the outer rear seats.

²⁾ We recommend the use of each system until the child reaches the upper weight limit.

B¹ = Conditional, without front passenger's airbags or with seat occupancy recognition and Vauxhall child restraint systems with transponders.

The front passenger's seat must also have a height adjusting facility: Move to highest position, slide front passenger's seat all the way back and move front passenger's seat belt anchorage point to lowest possible position.

B² = Conditional, without side airbag with front passenger's seat slid all the way back, or with seat occupancy recognition and Vauxhall child restraint systems with transponders.

The front passenger's seat must also have a height adjusting facility: Move to highest position and slide front passenger's seat all the way back so that the seat belt runs towards the front from the anchorage point.

U = For universal use in combination with three-point seat belt.

+ = Vehicle seat available with ISO-FIX fixings. When using ISO-FIX, only ISO-FIX child restraint systems approved for the vehicle may be used.

++ = Only if both outboard rear seats are pushed back and are flush with the centre seat.

X = No child restraint system permitted.

Note

- Children under 12 years or under 150 cm tall should only travel in an appropriate child safety seat.
- When transporting children, use the child restraint systems suitable for the child's weight.
- Check that the child restraint systems have been correctly installed – see instructions provided with child restraint system.
- The covers of the Vauxhall child restraint system can be wiped clean.
- Do not stick anything on the child restraint systems and do not cover them with any other materials.
- Only allow children to enter and exit at the side facing away from the traffic.
- A child restraint system which has been subjected to stress in an accident must be replaced.
- Secure or remove child restraint systems carried in the vehicle when not in use.



Airbag system

Front airbag

The front airbag system is identified by the word **AIRBAG** on the steering wheel and above the glove compartment *.

The front airbag system comprises:

- An airbag with inflator in the steering wheel and a second behind the trim panel above the glove compartment,
- The control electronics with impact sensor,
- Control indicator for airbag systems * in the instrument cluster,

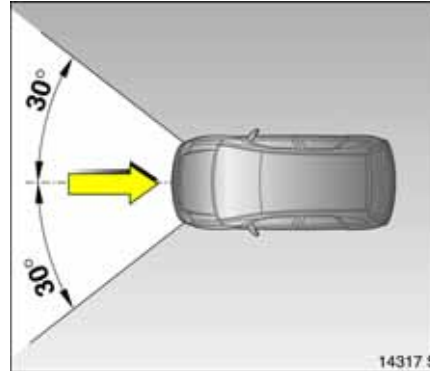

- Seat occupancy recognition *,
- The control indicator for Vauxhall child restraint systems with transponders * in the courtesy light.

The front airbag system will be triggered:

- Depending on the severity of the accident,
- Depending on the type of impact,
- Within the range shown in the illustration,
- Independently of the side airbag system * and curtain airbag system *.

Exception:

Front passenger's seat with seat occupancy recognition system *.

The seat occupancy recognition system deactivates the front and side airbags on the passenger's side if the front passenger's seat is unoccupied, or a Vauxhall child restraint system with transponders * has been fitted to the front passenger's seat.

Seat occupancy recognition – see page 73.

Vauxhall child restraint system with transponders * – see page 74.

Examples of events triggering the front airbag system:

- Impact against a non-yielding obstacle:
The front airbags are triggered at low vehicle speeds.
- Impact against a yielding obstacle (such as another vehicle):
The front airbags are only triggered at higher vehicle speeds.

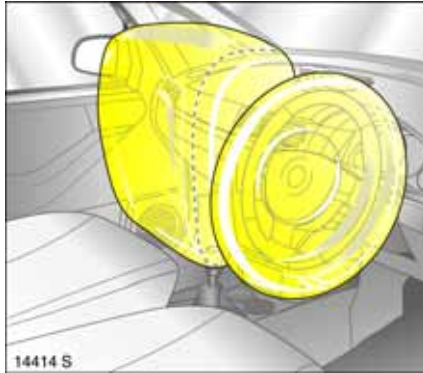

When triggered, the front airbags inflate in milliseconds to form a safety cushion for the driver and front passenger. The forward movement of the front seat occupants is checked, thereby substantially reducing the risk of injury to the upper body and head.

No impairment of view will occur, because the airbags inflate and deflate so quickly.



⚠Warning

The front airbag system provides optimum protection when the seat, backrest and head restraint are correctly adjusted: Adjust the driver's seat according to the occupant's height such that with the driver sitting upright the steering wheel is held in the area of its upper spokes with the driver's arms slightly bent.

The front passenger's seat should be as far back as possible, with the backrest upright (see pages 3, 44). Do not place your head, body, hands or feet on the covers of the airbag systems.

Do not place any objects in the area in which the airbags inflate. Important information – see page 75.



⚠Warning

The three-point seat belt must be correctly fitted – see page 62.

The front airbag system will not be triggered in the event of:

- The ignition being switched off,
- Minor frontal collisions,
- Accidents in which the vehicle overturns,
- Collisions involving a side or rear-impact,

that is to say, if it would not be of benefit to the occupants.

Warning

Seat belts must therefore always be worn. The front airbag system serves to supplement the three-point seat belts. If you do not wear your seat belt, you risk being seriously injured, or even thrown from the vehicle, in the event of an accident.

In the event of an accident, the belt helps to keep you in the correct seating position, so that the front airbag system can provide you with effective protection.

In addition, the front airbag system will not be triggered for the front passenger in model variants with seat occupancy recognition * if:

- The front passenger's seat is unoccupied,
 - There is a properly fitted Vauxhall child restraint system with transponders *.
- Seat occupancy recognition – see page 73.

Vauxhall child restraint system with transponders * – see page 74.

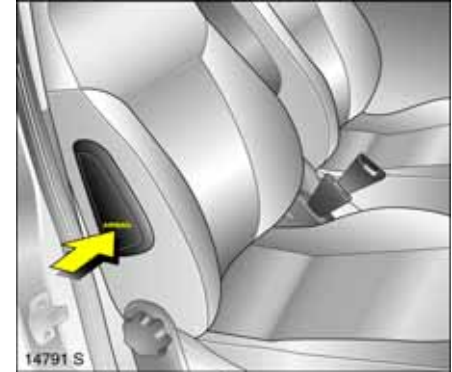

Side airbag *

The side airbag system is identified by the word **AIRBAG** on the outboard sides of the front seat backrests.

The side airbag system comprises:

- An airbag with inflator in the back of the driver's and front passenger's seat respectively,
- The control electronics,
- The side-impact sensors,
- Control indicator for airbag systems * in instrument cluster,
- Seat occupancy recognition *,
- The control indicator for Vauxhall child restraint systems with transponders * in the courtesy light.



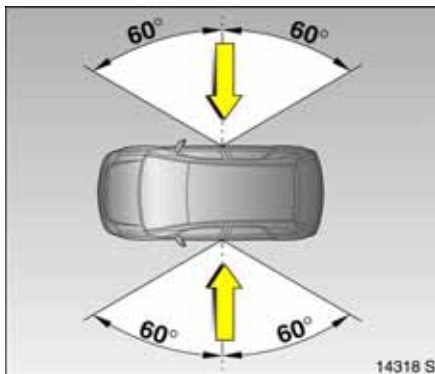

The side airbag system will be triggered:

- Depending on the severity of the accident,
- Depending on the type of impact,
- Within the range shown in the illustration, from the centre door pillar on the driver's or front passenger's side,
- Independently of the front airbag system.

Exception:

Front passenger's seat with seat occupancy recognition system ✱. The seat occupancy recognition system deactivates the passenger's front and side airbags if the front passenger's seat is unoccupied, or a Vauxhall child restraint system with transponders ✱ has been fitted to the front passenger's seat.

Seat occupancy recognition – see page 73.

Vauxhall child restraint system with transponders ✱ – see page 74.

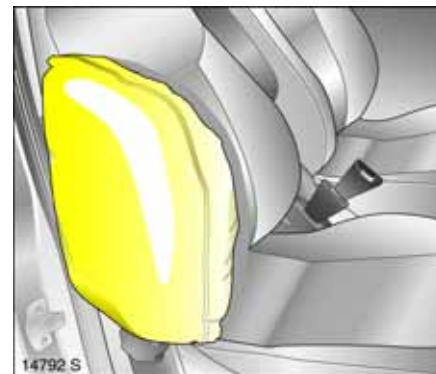

When deployed, the side airbag inflates within milliseconds to form a safety cushion for the driver or front passenger in the respective front door area. This substantially reduces the risk of injury to the upper body and pelvis in the event of a side-on collision.

Warning

There must be no objects in the area in which the airbag inflates or in the area between the seat backs and the vehicle body. Do not place the hands or arms on the covers of the airbag systems.

Important information – see page 75.

The three-point seat belt must always be correctly fitted – see page 62.

The side airbags will not be triggered in the event of:

- The ignition being switched off,
- Frontal collisions,
- Accidents in which the vehicle overturns,
- Collisions involving a rear-impact,
- Collisions involving a side-impact outside the passenger cell.

In addition, the side airbag system will not be triggered for the front passenger in model variants with seat occupancy recognition * if:

- The front passenger's seat is unoccupied,
- There is a properly fitted Vauxhall child restraint system with transponders *.

Seat occupancy recognition – see page 73.

Vauxhall child restraint system with transponders * – see page 74.



Curtain airbag *

The curtain airbag system is identified by the word **AIRBAG** on the roof pillar trim.

The curtain airbag system comprises:

- An airbag with inflator in the roof frame on the driver's and front passenger's side respectively,
- The control electronics,
- The side-impact sensors,
- Control indicator for airbag systems * in the instrument cluster.

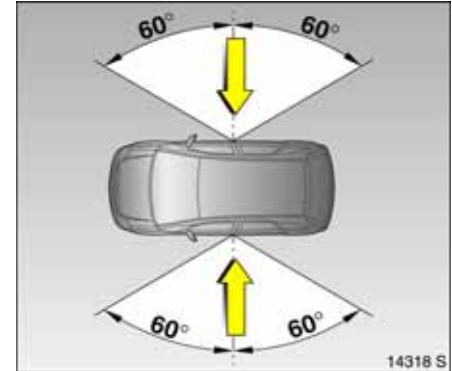

The curtain airbag system will be triggered:

- Depending on the severity of the accident,
- Depending on the type of impact,
- Within the range shown in the illustration, from the centre door pillar on the driver's or front passenger's side,
- Together with the side airbag system,
- Irrespective of seat occupancy recognition,
- Independently of the front airbag system.



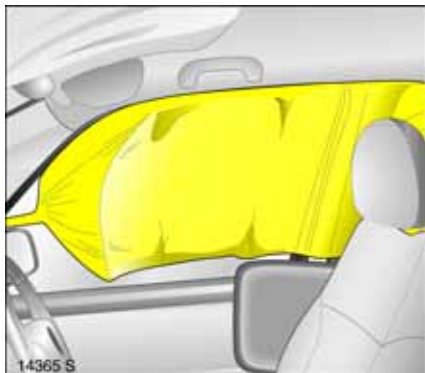

When the curtain airbag is triggered, it inflates within milliseconds and provides a safety barrier in the head area on the respective side of the vehicle. This reduces the risk of injury to the head considerably in case of a side-impact.

Warning

There must be no objects in the area in which the airbag inflates or in the area between the seat backrests and the vehicle body.

Do not place the hands or arms on the covers of the airbag systems.

Important information – see page 75.



The three-point seat belt must always be correctly fitted – see page 62.

The curtain airbags will not be triggered in the event of:

- The ignition being switched off,
- Frontal collisions,
- Accidents in which the vehicle overturns,
- Collisions involving a rear-impact,
- Collisions involving a side-impact outside the passenger cell.



Control indicator for airbag systems

The function of the airbag systems is monitored electronically together with the seat occupancy recognition  and the belt tensioners, and indicated by the control indicator .

When the ignition is switched on, the control indicator illuminates for approx. 4 seconds. If it does not illuminate, does not go out after 4 seconds or illuminates while driving, there is a fault in the airbag systems, seat occupancy recognition  or in belt tensioners. See also page 60. The systems may fail to trigger in the event of an accident.

Deployed airbags are indicated by continuous illumination of .

⚠ Warning

Have the cause of the fault eliminated immediately by a workshop.

Self-diagnosis integrated into the system allows rapid fault identification.

Seat occupancy recognition *

The seat occupancy recognition system deactivates the front and side front passenger's airbags if the front passenger's seat is unoccupied or a Vauxhall child restraint system with transponders * has been fitted to the front passenger's seat. The curtain airbag system * remains activated.

The control indicator for seat occupancy recognition ⓘ is located in the front courtesy light. If control indicator ⓘ illuminates for approx. 4 seconds after the ignition is switched on, the vehicle is equipped with seat occupancy recognition – see page 74, Fig. 12135 S.

If a Vauxhall child restraint system with transponders * is fitted, control indicator ⓘ illuminates permanently after the ignition is switched on, as soon as the system has detected the child restraint system. Only then may the child restraint system with transponders * be used on the front passenger's seat.



Vehicles with seat occupancy recognition can be identified by the sticker on the front passenger's seat or on the side of the instrument panel.

Vauxhall child restraint systems with transponders * are automatically detected if correctly fitted to the front passenger's seat. When these child restraint systems are being used on the front passenger's seat, the front and side airbag systems for the front passenger's seat are deactivated. The curtain airbag system remains activated.

Pay attention to the control indicator ⓘ for seat occupancy recognition * – see page 74.

⚠ Warning

Only Vauxhall child restraint systems with transponders * can be fitted on the front passenger's seat. Use of systems without transponders poses a risk of fatal injury.

Vauxhall child restraint systems with transponders * can be identified by a sticker or badge.

Control indicator  for Vauxhall child restraint systems with transponders *

The presence of a Vauxhall child restraint system with transponders is indicated after the ignition has been switched on, by permanent illumination of the control indicator  in the front courtesy light, as soon as the seat occupancy recognition system has detected the child restraint system.



If control indicator  does not illuminate while driving, the front and side airbags for the front passenger's seat have not been deactivated and there is a risk of fatal injury to the child. In this case, only fit child restraint systems to the outer rear seats. Have the cause of the fault eliminated by a workshop.

If the child restraint system is not correctly installed or the transponders are defective, the control indicator will flash. Check for correct child restraint system installation.

For installation of child restraint system with transponders * – see instructions provided with child restraint system.

If control indicator  flashes when the child restraint system with transponders is correctly fitted, there is a fault, with risk of fatal injury to the child. In this case, only fit child restraint systems to the outer rear seats. Have the cause of the fault eliminated by a workshop.

If no Vauxhall child restraint system with transponders is fitted, the control indicator must not illuminate or flash, as the front passenger's airbag systems would not deploy in the event of a collision. Have the cause of the fault eliminated by a workshop.

Warning

If a Vauxhall child restraint system with transponders has been fitted according to the instructions, the control indicator for Vauxhall child restraint systems with transponders  must illuminate in the front courtesy light when the ignition is switched on.

If the control indicator does not illuminate while driving, the front passenger's airbag systems have not been deactivated and there is a risk of fatal injury. In this case, fit child restraint systems to the outer rear seats only. Have the cause of the fault eliminated by a workshop.



Important

- Due to risk of injury when the airbags deploy, accessories and objects should not be placed within the expansion range of the airbag systems.
- Do not place any objects between the airbag systems and the vehicle occupants; risk of injury.

Warning

Never carry child restraint systems or other objects on your lap - risk of fatal injury.

- Use the hooks in the roof frame only to hang up light articles of clothing or coat hangers. Do not place any objects in the pockets of the hanging items – risk of injury.
- The airbag systems and belt tensioner control electronics can be found in the centre console area. In order to avoid malfunctions, do not store magnetic objects in this area.

- Do not stick anything on the steering wheel, instrument panel, front seat backrests or roof frame, in the vicinity of the airbags, or on the front passenger's seat cushion, or cover any of those areas with other materials.
- Use only a dry cloth or interior cleaner to clean the steering wheel, instrument panel, front seat backrests, roof frame and seat cushion of the front passenger's seat. Do not use any aggressive cleaning agents.
- Only protective covers which are approved for your vehicle with side airbag may be fitted on the front seats. When fitting the protective covers, make sure that the airbag units on the outboard sides of the front seat backrests are not covered.
- The airbag systems are triggered independently of each other depending on the severity of the accident and the type of impact. The side airbag system  and the curtain airbag system  are triggered together. See seat occupancy recognition  on page 73 for exceptions.
- Each airbag deploys once only. Have a workshop replace deployed airbags immediately.

- The speeds, directions of movement and deformation properties of the vehicles, and the properties of the obstacle concerned, determine the severity of the accident and triggering of the airbags. The degree of damage to your vehicle and the resulting repair costs alone are not indicative that the criteria for triggering of the airbags were met.
- Do not perform any alterations on the components of the airbag system, as this would render the vehicle unroadworthy.

⚠ Warning

The systems can be triggered abruptly and cause injury if they are handled improperly.

- We recommend having the steering wheel, the instrument panel, all panelling parts, the door seals, the handles and the seats removed by a workshop.

- When disposing of the vehicle, the safety instructions given for this must be observed. Take the vehicle to a recycling company for disposal.
- Persons weighing less than 35 kg should only travel on the rear seats. This does not apply to children who are travelling in child restraint systems with transponders ✱.
- In vehicles with seat occupancy recognition ✱, do not place any heavy objects on the front passenger's seat otherwise the airbag systems for the front passenger's seat may be triggered in the event of an accident.
- In vehicles with seat occupancy recognition ✱, to prevent malfunctions do not use protective covers or extra seat cushions on the front passenger's seat.

- When using a Vauxhall child restraint system with transponders ✱ on the front passenger's seat, in order to prevent malfunctions, no objects (e.g. plastic sheet, stickers or heated mats) may be placed under the child restraint system.

⚠ Warning

Child restraint systems as well as other objects must never be carried on the lap of passengers; risk of fatal injury. If carried in this way, child restraint systems with transponders ✱ in vehicles with seat occupancy recognition ✱ could lead to front passenger's airbag systems not being triggered in the event of an accident.

Use of child restraint systems * on the front passenger's seat in vehicles with airbag systems *, but without seat occupancy recognition *

⚠ Warning

Vehicles with front passenger's airbag without side airbag *: Child restraint systems facing the rear of the vehicle must not be installed on the front passenger's seat, risk of fatal injury.

Child restraint systems facing the direction of travel (child restraint systems for weight classes I, II and III, see page 65) may be installed on the front passenger's seat if the seat has been pushed back as far as it will go and the backrest has been adjusted such that the lap belt fits snugly.



Vehicles with front passenger's airbag can be recognised by the word **AIRBAG** above the glove compartment and by the sticker on the instrument panel on the passenger's side - see illustration above.

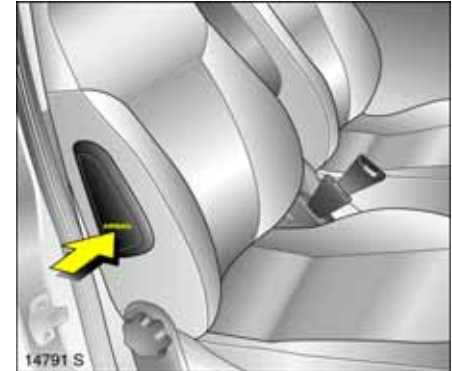

⚠ Warning

Vehicles with side airbag *: No child restraint system * may be fitted on the front passenger's seat, risk of fatal injury.

A vehicle with side airbags can be identified by the word **AIRBAG** on the outboard sides of the front seat backrests.

Seat occupancy recognition * – see page 73.



Use of child restraint systems * on front passenger's seat in vehicles with airbag systems * and with seat occupancy recognition *

Warning

Only Vauxhall child restraint systems with transponders * can be fitted on the front passenger's seats. Use of systems without transponders poses a risk of fatal injury.

Vehicles with seat occupancy recognition are identified by a sticker on the lower panel of the front passenger's seat – see illustration above.



Vehicles with seat occupancy recognition can also be recognised by control indicator  in the front courtesy light.

If control indicator  illuminates for approx. 4 seconds after the ignition is switched on, the vehicle is equipped with seat occupancy recognition - see page 73.

The seat occupancy recognition system detects Vauxhall child restraint systems with transponders * and switches off the front and side airbag systems for the front passenger's seat. The curtain airbag system remains activated.

Seat occupancy recognition – see page 73.

Vauxhall child restraint systems with transponders * can be identified by a sticker or badge.



Cigarette lighter *

The cigarette lighter is behind the ashtray cover.

The cover opens when pressed at the centre point. See Fig. 14354 S on page 80.

Press in cigarette lighter with the ignition switched on. Switches off automatically when element is glowing. Withdraw cigarette lighter.



Accessory sockets *

An accessory socket is located behind the ashtray cover. Additional accessory sockets * can be found in the centre console in front of the backrests and in the luggage compartment.

Accessory sockets can be used to connect electrical accessories.

Accessory sockets are operable when the ignition is switched on. Use of the sockets while the engine is not running will drain the battery.

Do not damage the socket by using unsuitable plugs.

The maximum power consumption of electrical accessories must not exceed 120 watts.

Do not connect any current-delivering accessories, e.g. electrical charging devices or batteries.

Electrical accessories connected to the socket must comply with the electromagnetic compatibility requirements laid down in DIN VDE 40 839, otherwise vehicle malfunctions may occur.

If the tyre repair kit is * is in operation, no consumers may be connected to the auxiliary socket.



Ashtrays

To be used only for ash and not for combustible rubbish.

Warning

Failure to observe these descriptions can lead to injuries which may be fatal. Vehicle passengers must be informed accordingly.

Ashtray, front

The cover opens when pressed at the point indicated.

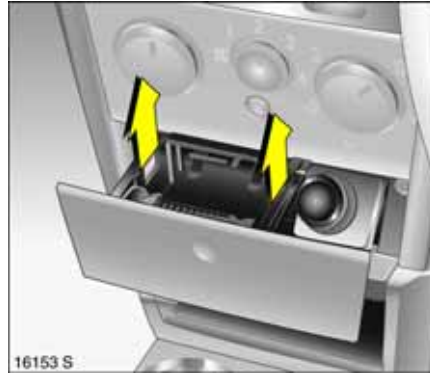

To empty, grip both sides of the ashtray insert at the points illustrated and pull upwards.

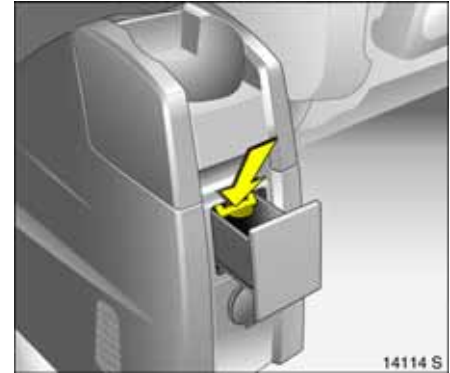

Rear ashtray*

In the rear centre console.

To open, pull ashtray towards the rear of the vehicle.

To empty, open the ashtray, press the spring (see arrow in illustration) and pull out the ashtray.

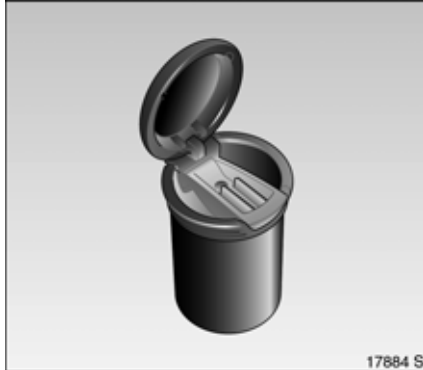

17884 S

Ashtray *

For universal use in vehicle interiors, e.g. in the front or rear of the centre console or in foldaway tables * (see next page).

Open cover to use.

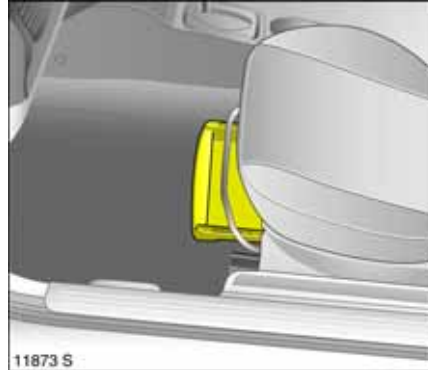

11873 S

Stowage compartments

Stowage compartment beneath front passenger's seat *

Lift tray by grasping recessed edge and pull forwards. Maximum load: 1 kg.

To close the tray, push it in and lock it in place.



14409 S

Glove compartment

To open, pull handle upwards.

On the inside of the glove compartment cover there is a pen holder.

The glove compartment should be closed while driving.

Cooled glove compartment * – see page 119.

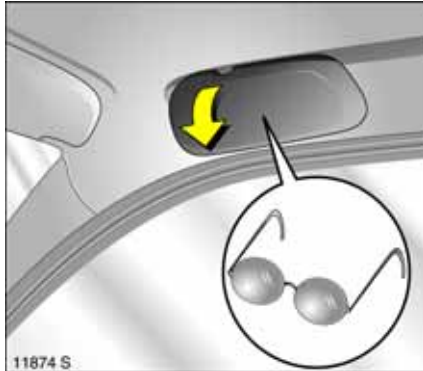

Stowage compartment for glasses*

Located on driver's side. Fold down to open.

Do not store heavy objects in the stowage compartment.

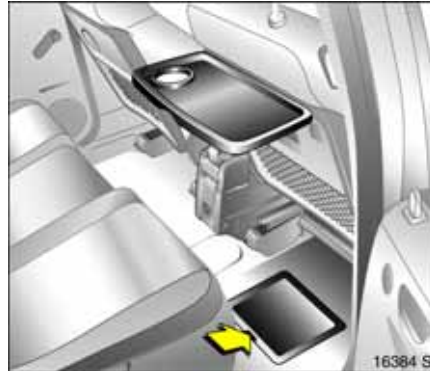

Stowage compartments in rear footwell*

To open, unclip cover at recess and lift up.

Foldaway tables *

Located on the front seat backrests.

Open by pulling upwards until it engages.

Fold away by pressing down past the resistance point.

Do not place any heavy objects on the foldaway tables.

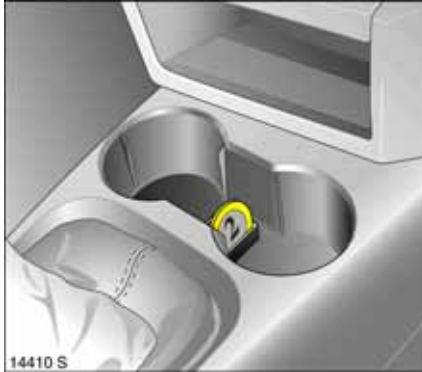

Coin holder

Located in the centre console.

Sunvisors

Use the sunvisor to protect from glare, by pulling it down and/or swivelling it to the side.

While driving, the mirrors in the sunvisors should be covered.

Instruments, Controls

Control indicators	84
Instrument display	89
Information display	92
Warning buzzers.....	103
Windscreen wiper	103
Windscreen wash system and headlight wash system *.....	104
Rear window wash and wiper system	104

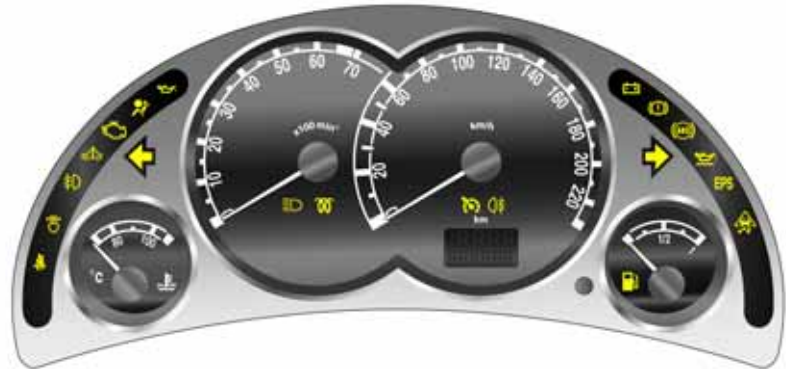

17876 S

Control indicators

The control indicators described here are not present in all vehicles. The descriptions however, apply to all instrument versions.

The control indicator colours mean:

- Red Danger, important reminder,
- Yellow Warning, note, fault,
- Green On confirmation,
- Blue On confirmation.



Seat belt warning device *

Control indicator illuminates in red.

Illuminates after turning on the ignition (with warning tone) until the seat belt is applied. Apply seat belt, see page 62.



Adaptive Forward Lighting (AFL) *

Control indicator illuminates in yellow.

If it is illuminated:

Fault in system.

Contact a workshop for help.

AFL * – see page 109.



Front fog lights *

Control indicator illuminates in green.

It is illuminated when the front fog lights are on – see page 106.



Engine electronics, transmission electronics, immobiliser, diesel fuel filter *, Easytronic *, fault
Control indicator illuminates or flashes in yellow.

It illuminates for a few seconds when the ignition is switched on.

Illuminates when the engine is running:

Fault in engine or gearbox electronic system. Electronics have switched to emergency running programme. Fuel consumption may be increased and the vehicle's driveability reduced, see page 147. Contact a workshop immediately.

For vehicles with a diesel engine, the diesel fuel filter may need to be drained of water, see page 230.

If it flashes when the ignition is on:

Fault in the electronic immobiliser system; the engine cannot be started – see page 27.



Exhaust emission

Control indicator illuminates or flashes in yellow.

It illuminates when the ignition is switched on and goes out shortly after the engine starts.

If it illuminates when the engine is running:
Fault in emission control system. The permitted emissions may be exceeded. Contact a workshop immediately.

If it flashes when the engine is running:
Fault which could lead to damage to the catalytic converter, see page 147. Contact a workshop immediately.



Airbag systems *, belt tensioners

Control indicator illuminates in red.

If it illuminates when the engine is running:
Fault in the airbag or belt tensioner systems, see pages 60, 72.



Engine oil pressure

Control indicator illuminates in red.

It illuminates when the ignition is switched on and goes out shortly after the engine starts.

If it illuminates when the engine is running:
Engine lubrication may be interrupted. This may result in damage to the engine and/or locking of the drive wheels:

1. Move out of the flow of traffic as quickly as possible, without impeding other vehicles.
2. Depress clutch.

3. Move gearshift lever to neutral, or with Easytronic , place selector lever in **N**.
4. Switch off ignition.

Warning

When the engine is off, considerably more force is needed to brake and steer.

Do not remove key until vehicle has come to a standstill, otherwise the steering column lock could engage unexpectedly.

Check oil level before contacting a workshop.



Turn signal lights

Control indicator flashes green.

The corresponding control indicator flashes on the side selected.

Both control indicators flash with the hazard warning lights on.

Rapid flashing:

Failure of a turn signal bulb or associated fuse.

Change bulbs, see page 190.

Fuses, see page 188.



Headlight main beam

Control indicator illuminates in blue.

It is illuminated when main beam is on and during headlight flash – see pages 9, 105.



Easytronic ✱, start engine

Control indicator illuminates in yellow.

It illuminates if the footbrake is not applied when starting the engine. The indicator goes off as soon as the footbrake is applied. The engine can only be started with the footbrake applied, see page 133.



Easytronic winter programme ✱

Control indicator is illuminated when winter programme is enabled.

Further information – see page 135.



Cruise control ✱

Control indicator illuminates in green.

It is illuminated when the system is on – see page 151.



Fog tail light

Control indicator illuminates in yellow.

It is illuminated when the fog tail light is on – see page 107.



Alternator

Control indicator illuminates in red.

It illuminates when the ignition is switched on and goes out shortly after the engine starts.

If it illuminates when the engine is running: Stop, switch off engine. Battery is not charging. Check drive belt condition and tensioning before contacting a workshop.



Brake system, clutch system ✱

Control indicator illuminates or flashes in red.

It illuminates after the ignition is turned on, when the handbrake is applied or if the brake or clutch fluid level is too low. For further information, see pages 156, 232.

Warning

Illuminates when the handbrake is applied. Stop driving immediately. Contact a workshop immediately.

On vehicles with Easytronic ✱, control indicator (Ⓢ) flashes for a few seconds after the ignition is switched off, if the handbrake has not been applied.



Anti-lock Brake System (ABS)

Control indicator illuminates in red.

If it illuminates while driving:
Fault in ABS, see page 156.



Engine oil level *

Control indicator illuminates in yellow.

In vehicles with engine oil level check, the oil level is checked automatically.

If it illuminates when the engine is running:
 Engine oil level too low. Check engine oil level and top up engine oil if necessary, see page 228.

EPS¹⁾

Electric Power Steering

Control indicator illuminates in yellow.

Fault in Electric Power Steering. Vehicle can still be driven, but greater force is required for steering. Contact a workshop immediately.

¹⁾ EPS = Electric Power Steering.



Electronic Stability Programme (ESP[®] Plus) *

Control indicator flashes or illuminates in yellow.

If it flashes during driving:
 System actively engaged, see page 149.

If it illuminates while driving:
 Fault in Electronic Stability Programme, see page 149.



Fuel level

Control indicator illuminates or flashes in yellow.

If it illuminates:
 Low fuel level, fuel gauge in reserve area.

If it flashes:

Fuel supply exhausted, refuel immediately.
 Never let the tank run dry!

Erratic fuel supply can cause catalytic converter to overheat, see page 145.

Diesel engines:
 If the tank is run dry, bleed the fuel system as described on page 170.



Preheating system for diesel engines *, diesel particle filter *

Control indicator illuminates in yellow.

Preheating system active, switches on only if outside temperature is low.

If it flashes (with diesel particle filter):
 Diesel particle filter must be cleaned. Continue driving, and as soon as road and traffic conditions allow, increase speed to over 25 mph (40 km/h) to start cleaning of the diesel particle filter. The control indicator goes out when cleaning is complete. We recommend not turning off the ignition during cleaning.

Further information – see page 148.



12135 S



Seat occupancy recognition *
see pages 67, 73.



17879 S

Instrument display

In some versions, the pointers of the tachometer, the speedometer, the coolant temperature gauge and the fuel gauge briefly go to the endstop as a functionality check.

Tachometer

Indicates engine speed.

Warning zone: Maximum permissible engine speed exceeded; danger to engine.

Speedometer

Speed display.

Mileage / kilometre display

If the ignition is off, the mileage is displayed for approx. 15 seconds by briefly pressing the reset knob.

Top line:

Trip odometer

Display of miles / kilometres covered since last reset.

To reset, hold the reset knob depressed for a few seconds when the ignition is switched on.

Bottom line:

Odometer

Records the miles / kilometres driven.

Maintenance, Inspection system - see pages 91, 226.



Coolant temperature display

Pointer in zone at left = Engine operating temperature not yet reached.

Pointer between the zones = Normal operating temperature.

Pointer in zone at right (warning zone) = Temperature too high:
Stop vehicle and switch off engine. Danger to engine. Check coolant level, see page 231.

For physical reasons, the engine temperature gauge shows the coolant temperature only if the coolant level is adequate.

During operation, the system is pressurised. The temperature may therefore rise briefly to over 100 °C.



Fuel gauge

Pointer in red warning zone or fuel pump icon illuminated = Reserve level.

Pointer in red warning zone or fuel pump icon flashing = Refuel immediately – see page 143.

Never run the tank dry!

Diesel engines: If the tank is run dry, bleed the fuel system as described on page 170.

Because of the fuel remaining in the tank, the amount of fuel required to fill the tank may be less than the specified tank capacity.



Service display *

When the indicator in the display of the odometer appears, make a Service appointment with a workshop as soon as possible.

Maintenance, Inspection system - see page 226.



Transmission display *

Display of current gear or mode with Easytronic *.

- R Reverse gear.
- N Neutral.
- A Automatic mode of Easytronic.
- 1-5 Manual mode, current gear of Easytronic.

Easytronic * - see page 132.



Information display

Triple Information Display *

Display of time, outside temperature and date / Infotainment system (when it is on).

When the ignition is off, the time, date and outside temperature can be made to appear for approx. 15 seconds by briefly pressing one of the two buttons adjacent to the display.

An **F** in the display indicates a fault. Have the cause eliminated by a workshop.

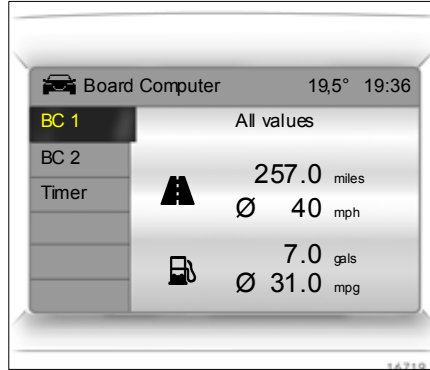

Graphical Information Display *

Colour Information Display *

Display of time, outside temperature and date / Infotainment system (when it is on).

The Graphical Information Display presents the information in monochrome. The Colour Information Display presents the information in colour.

The information that is displayed depends on the Infotainment system configuration. Some information appears in the display in an abbreviated form.

For Infotainment system, see Infotainment system operating instructions.

An **F** in the display indicates a fault. Have the cause eliminated by a workshop.



Outside temperature

A fall in temperature is indicated immediately and a rise in temperature after a time delay.

If the external temperature falls to 3 °C, to warn of ice on the road the symbol ❄️ appears in the Triple Information Display. When the temperature climbs, the symbol ❄️ goes out above 5 °C.



In vehicles with Graphical Information Display ❄️ or Colour Information Display ❄️, an icy road surface warning message appears in the display.

No message is displayed if the temperature is less than -5 °C.

⚠️ Warning

Caution: The road surface may already be icy, even though the display indicates a few degrees above 0 °C.

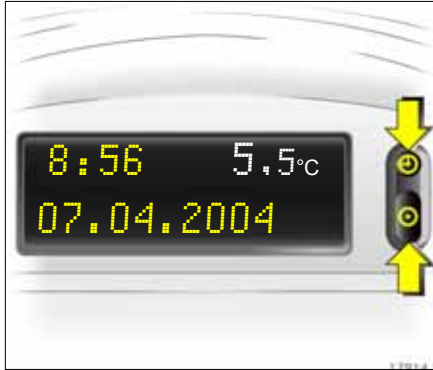

Triple Information Display

Set date and time

With Infotainment system off, press \oplus and \ominus next to the display as follows:

Press \oplus for approx. 2 seconds:

Day flashes

\oplus : Set day

\ominus : Month flashes

\oplus : Set month

\ominus : Year flashes

\oplus : Set year

\ominus : Hours flash

\oplus : Set hours

\ominus : Minutes flash

\oplus : Set minutes

\oplus : Clock is started.

Correcting time:

Some RDS transmitters do not send a correct time signal. If the incorrect time is displayed on frequent occasions, deactivate automatic time synchronisation – see next column, and set the time manually.

The automatic setting is indicated by \oplus in the display.

Deactivating / activating automatic time synchronisation: With Infotainment system off, press \oplus and \ominus next to the display:

Hold down \oplus for approx. 2 sec., clock display is now in setting mode,

Press \oplus twice (until year flashes).

Press \oplus and hold down for approx. 3 seconds until \oplus flashes in display * and text "RDS TIME" appears (years flash during this time),

Press \oplus ; display shows:

RDS TIME 0 = Off

Press \ominus ; display shows:

RDS TIME 1 = On

Press \oplus three times.



Graphical Information Display * or Colour Information Display *, selecting functions

Functions and their menus are shown in the Graphical Information Display and Colour Information Display.

These functions are highlighted or executed in the menu display via the four-way button, the multi-function knob * on the Infotainment System or the remote control buttons * on the steering wheel.



To select with four-way button

Select menu items via menus and with the buttons / four-way button of the Infotainment system.



Selection with the multi-function knob *

Turn:
Highlighting of menu options or commands, selection of function ranges.

Press:
Selection of highlighting, confirmation of commands.

To exit a menu, turn the multi-function knob left or right to **Return** or **Main** and select.





Selection using remote control buttons * on steering wheel
 Select menu options via menus and with the buttons.



For each functional area, there is a main page (Main), which is selected at the top edge of the display (not with the Infotainment system CD 30 without the hands-free mobile phone system):

- Audio,
- Navigation *,
- Telephone *,
- Trip computer *.

Function areas audio, navigation * and telephone * – see Infotainment system operating instructions.

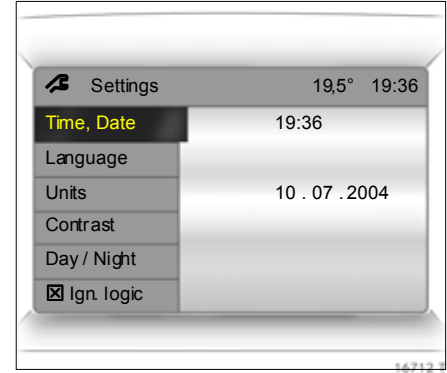

System settings

The settings are accessed via the **Settings** menu.

Press the **Main** button * (not found on all Infotainment systems) on the Infotainment system (call up main display).

Press the **Settings** button on the Infotainment system. For Infotainment system CD 30, no menu may be selected.

The **Settings** menu is displayed.

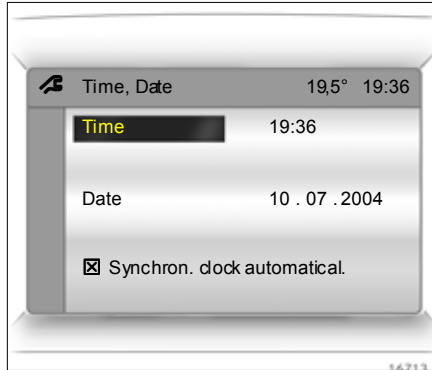

Setting the date and time ✳

Select menu item **Time, Date** from the **Settings** menu.

The menu for **Time, Date** is displayed.

Select the menu items required.

Make the desired setting.

Correcting time:

Some RDS transmitters¹⁾ do not send correct time signals. If the incorrect time is frequently displayed, deactivate automatic time synchronisation and set the time manually.

To correct time with the help of RDS, select menu item **Synchron. clock automatical.** from the **Time, Date** menu.

The box in front of **Synchron. clock automatical.** will be ticked – see Fig. 16713 T.

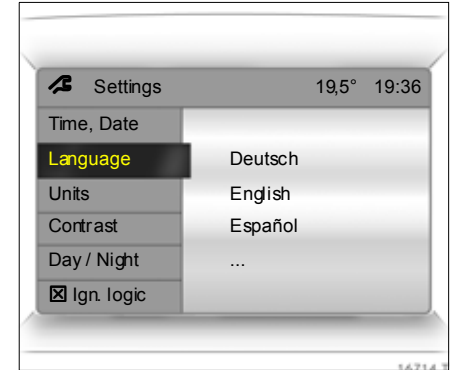

Language selection

You can select the display language for some functions.

Select menu item **Language** from the **Settings** menu.

The available languages are displayed.



¹⁾ RDS = Radio Data System.

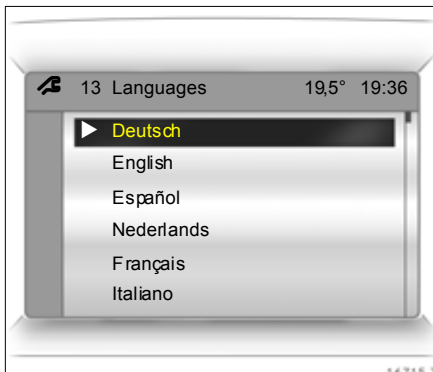

Select the desired language.

Selections are indicated by a ► in front of the menu item.

In systems with voice output ✱, when the language setting of the display is changed, the system will ask whether the announcement language should also be changed – see Infotainment system operating instructions.

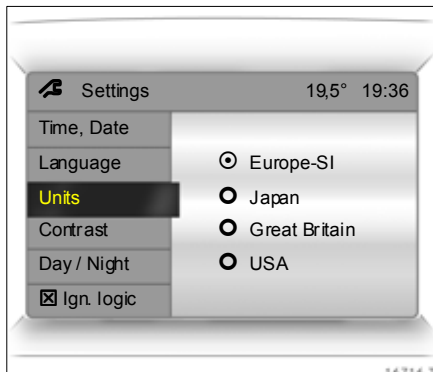

Setting units of measure

You can select which units of measure are to be used.

Select menu item **Units** from the **Settings** menu.

The available units are displayed.

Select the desired unit.

Selections are indicated by a ● in front of the menu item.

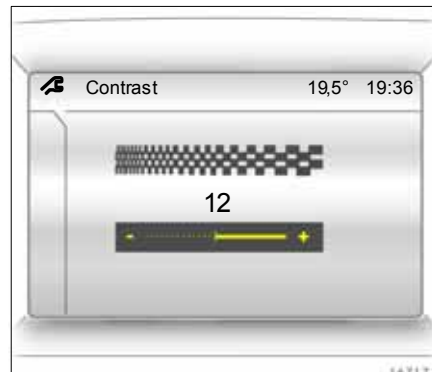

Adjusting contrast ✱

(Graphical Information Display)

Select menu item **Contrast** from the **Settings** menu.

The menu for **Contrast** is displayed.

Confirm the required setting.

Setting display illumination *

The display can be adjusted to suit the lighting conditions, black or coloured text on a light background or white or coloured text on a dark background.

Select menu item **Day / Night** from the **Settings** menu.

The options are displayed.

Automatic:

Adapted based on vehicle lighting.

Always day design:

Black or coloured text on light background.

Always night design:

White or coloured text on dark background.

Selections are indicated by a ● in front of the menu item.

Ignition logic *

See Infotainment system operating instructions.

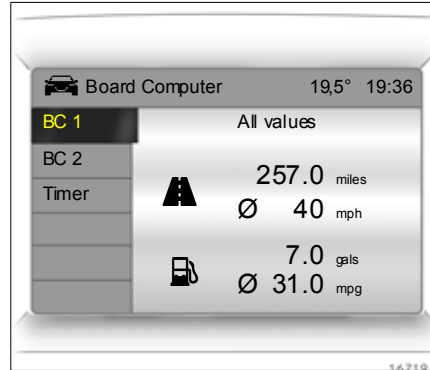
**Graphical Information Display * or Colour Information Display *, trip computer ***

The trip computers provide information on driving data, which is continually recorded and evaluated electronically.

The on-board computer main page gives information on range, instantaneous consumption and average consumption *.

To display the other trip computer driving information, press **BC** button on Infotainment system * or select trip computer menu on display.

For vehicles with Infotainment System CD 30 * and steering wheel remote control *, the left-hand steering wheel buttons only operate the trip computer.

**Range**

Range is calculated from current fuel tank content and instantaneous consumption. The display shows average values.

When the vehicle has been refuelled, the range is updated automatically after a brief delay.



If less than 30 miles (50 km) can be driven with the fuel remaining in the tank, the warning "Range" appears on the display.

If less than 20 miles (30 km) can be driven with the fuel remaining in the tank, the warning "Please refuel!" * appears on the display.

Acknowledge the menu item as described on page 95.

Instantaneous consumption

Display changes depending on speed:

Display in gal/h	below 8 mph (13 km/h),
Display in mpg	above 8 mph (13 km/h).

Distance travelled

Display of miles / kilometres travelled.

The measurement can be reset to zero at any time and restarted, see next column n.

Average speed

Calculation of average speed.

The measurement can be reset to zero at any time and restarted, see next column n.

Stoppages in the journey with the ignition off are not included in the calculations.

Effective consumption

Display of fuel used.

The measurement can be reset to zero at any time and restarted, see next column n.

Average consumption

Calculation of average consumption.

The measurement can be reset to zero at any time and restarted, see next column n.

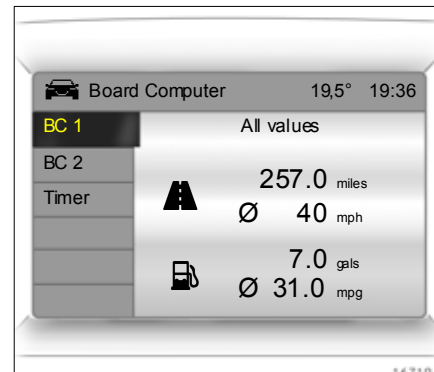

Reset trip computer information

The following trip computer information can be reset (restart measurements):

- Distance travelled,
- Average speed,
- Effective consumption,
- Average consumption.

Select **BC 1** or **BC 2** from the trip computer menu.

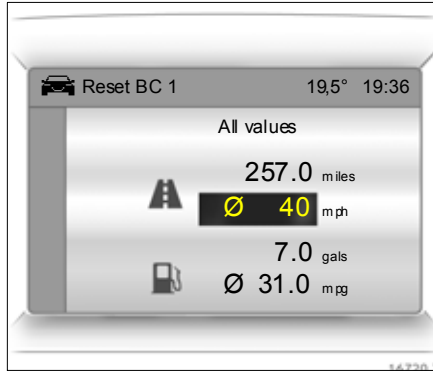

The information of both trip computers can be reset separately and therefore provides a facility for evaluating information over different time periods.

Select the desired trip computer information.

The value for the selected function will be reset and recalculated.

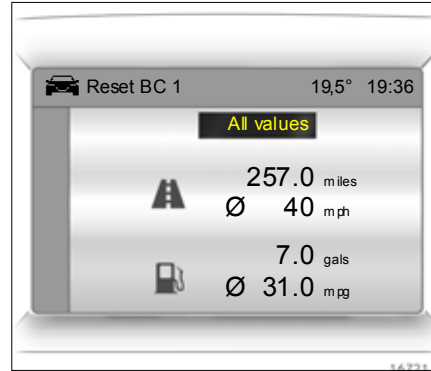

To reset all trip computer information, select menu item **All values**.

After resetting, "---" is displayed with the trip computer information selected. The recalculated values are displayed after a brief delay.

Interruption of power supply

If the power supply has been interrupted or if the battery voltage has dropped too low, the values stored in the trip computer will be lost.

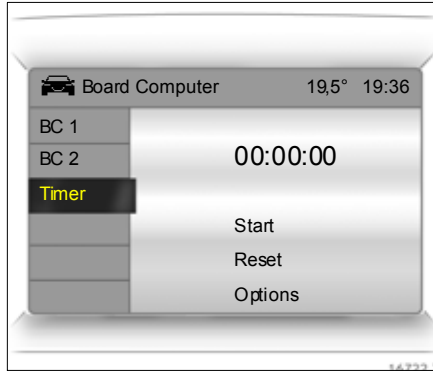

Stop watch

Select menu item **Timer** from the **Board Computer** menu.

The **Timer** menu is displayed.

To start, select menu item **Start**.

To reset, select menu item **Reset**.

The stop watch information to be displayed can be selected via menu **Options** *:

Driving Time excl. Stops

Measurement of the time the vehicle is in motion. Stationary time is not included.

Driving Time incl. Stops

Measurement of the time the vehicle is in motion. The time the vehicle is stationary with the key in the starter switch is included.

Travel Time

Measurement of the time from manual activation via **Start** to manual deactivation via **Reset**.

Warning buzzers

When starting the engine or while driving:

- if seat belt is not fastened ✱,
- if a specified maximum speed is exceeded ✱,
- for Easytronic ✱ - if **A**, **M** or **R** is selected while the engine is running and the driver's door is opened but the footbrake is not applied.

When the vehicle is parked and the driver's door is opened:

- with the key in the ignition,
- with parking lights or dipped beam switched on,
- if the turn signal stalk is engaged.

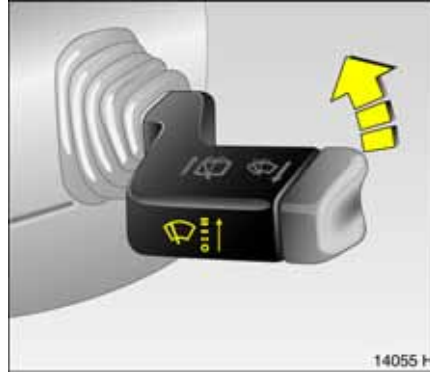

Windscreen wiper

To activate, press stalk briefly upwards

- = Off
- = Adjustable timed interval wipe
- = Slow
- ≡ = Fast

Adjustable wiper interval

Setting wiper interval to a value between 2 and 15 seconds:

Stalk to timed interval wipe position --, stalk to ○, wait for desired interval time, push stalk back to timed interval wipe position --.

The interval time selected remains stored until it is next changed or until the ignition is turned off.

After turning on the ignition and setting the lever to timed interval wipe position --, the interval is set to 7 seconds.



Windscreen wash system and headlight wash system *

To activate, pull stalk towards steering wheel.

The wiper will swipe for a few strokes.

The headlight wash system* can be operated when the lights are on.



Rear window wash and wiper system

To activate, push stalk forwards.

The rear window wiper swipes in timed interval mode.

To deactivate, pull stalk towards steering wheel.

If the stalk is held forwards, the rear window wash is engaged for the duration of activation.

The wiper will swipe for a few strokes when washing.

Lighting

Exterior lights	105
Main beam, headlight flash	106
Turn signal lights	106
Front fog lights \mathcal{F} \mathcal{D} *	106
Fog tail light \mathcal{Q} \mathcal{F}	107
Hazard warning lights	107
Headlight range adjustment \mathcal{D}	107
Adaptive Forward Lighting (AFL) *	109
Door-to-door lighting function *	110
Activating the exterior lighting with the remote control *	110
Instrument illumination \mathcal{Q} , Information display illumination	111
Courtesy light	111
Battery discharge protection *	113
Light covers	113
Headlights when driving abroad	113



Exterior lights

Turn light switch:

- \mathcal{O} = Off
- \mathcal{P} \mathcal{L} = Parking lights
- \mathcal{D} = Dipped beam
or main beam

In positions \mathcal{P} \mathcal{L} and \mathcal{D} , the tail lights and number plate lights are also on.

If the ignition is switched off with the dipped beam or main beam on, the parking lights illuminate *.

Vehicles with daytime running lights *:
With the ignition on and the light switch on \mathcal{O} , dipped beam without instrument illumination is on.

The daytime running lights switch off when the ignition is switched off.

Follow the regulations of the country in which you are driving when using daytime running lights and fog lights *.

Driving abroad – see page 113.

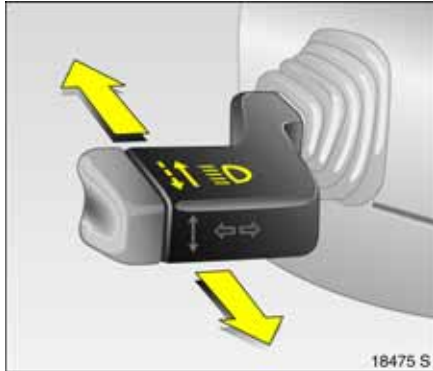

Main beam, headlight flash

To switch from dipped to main beam, push stalk forwards.

To switch to dipped beam, push stalk backwards again.

To activate the headlight flash, pull stalk towards steering wheel. Main beam is engaged for the duration of activation.

When the main beam or headlight flash is activated, the blue control indicator  lights.

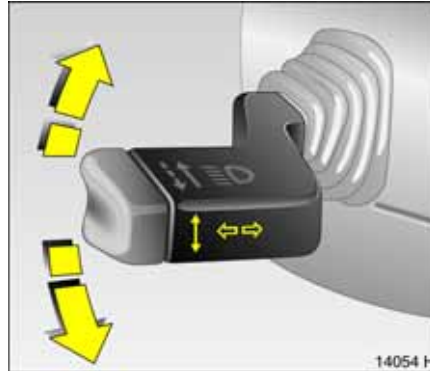

Turn signal lights

To activate, push stalk up or down.

Stalk up = Right turn signal light



Stalk down = Left turn signal light

If the stalk is moved past the resistance point, the turn signal light remains on. When the steering wheel moves back towards the straight-ahead position, the turn signal light is automatically deactivated.

Brief flash: Push stalk to resistance point and release.





Front fog lights *

On = Press ,  illuminates in instrument cluster.

Off = Press  again or switch off ignition or headlights.

The front fog lights can only be switched on when both the ignition and the headlights are on.

Fog tail light

- On = Press ,  illuminates in instrument cluster.
- Off = Press  again or switch off ignition or dipped beam / parking lights.

The fog tail light can only be switched on when both the ignition and the dipped beam / parking lights are on.

The fog tail light on the vehicle is deactivated when towing a caravan / trailer.

Reversing lights

Illuminate when reverse gear is engaged and the ignition is switched on.



Hazard warning lights

To activate, press button .

To deactivate, press button  again.

To aid location of the pushbutton, the red surface is illuminated when the ignition is switched on. When the button is pressed, its control indicator flashes in time with the hazard warning lights.



Headlight range adjustment

Manual headlight range adjustment
With dipped beam switched on, adjust headlight range in four steps to suit vehicle load. Push to release knob and turn it against resistance to the required position.

Correct adjustment of the headlight range reduces dazzle for other road users.

Front seats occupied = 0

All seats occupied = 1

All seats occupied and luggage compartment load = 2

Driver's seat occupied and luggage compartment load = 3

Automatic headlight range adjustment *

On vehicles with Xenon headlights, headlight range is adjusted automatically based on vehicle load.

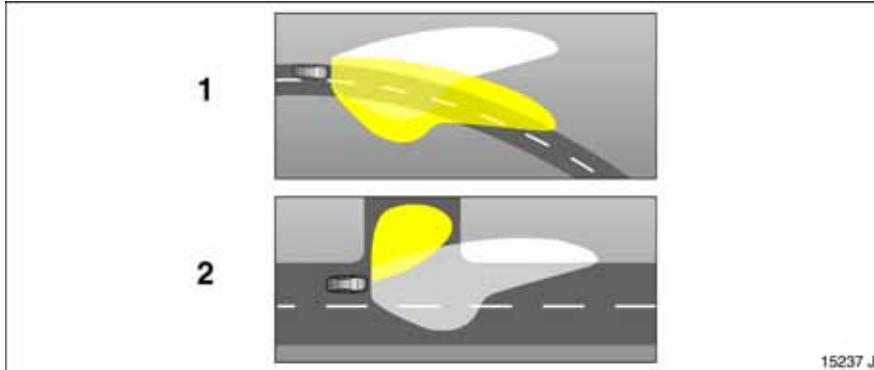

Adaptive Forward Lighting (AFL) *

AFL improves illumination of:

- Curves (curve lighting),
- Intersections and tight turns (turn lighting).

Curve lighting (1)

The light beam pivots based on steering wheel position and speed (from approx. 6 mph (10 km/h)).

The headlights shine at an angle of up to 15° to the right or left of the direction of travel.

Turn lighting (2)

An additional light illuminates at certain steering wheel positions (after approx. 90°), turn signal settings and speeds (up to approx. 25 mph (40 km/h)).

The light shines approx. 90° to the left or right of the vehicle and approx. 30 metres to the front.

Reverse function

Turning the headlights on, selecting reverse gear and switching a turn signal light on causes the turn lighting to be switched on for the respective side. When the turn signal is switched off, the turn lighting continues to illuminate for approx. 15 seconds.



Control indicator for adaptive driving lights

Illuminated: Fault in system.

The system is not ready for operation.

Contact a workshop.

The steering angle sensor must be calibrated after a power supply interruption, in order to make the system operational. See page 150.

If the control indicator  flashes for approx. 4 seconds after the ignition is switched on, this is a reminder that the headlights have been set to symmetrical dipped beam; see "Headlights when driving a broad" on page 113.

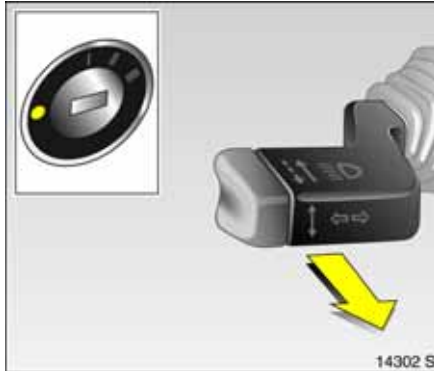

Door-to-door lighting function *

The dipped beam illuminates for approx. 30 seconds after leaving the vehicle and closing the driver's door.

To activate:

1. Switch off ignition.
2. Remove ignition key.
3. Open driver's door.
4. Pull turn signal stalk towards steering wheel.
5. Close driver's door.

If the driver's door is left open, the lights will go out after approx. two minutes.

The light goes out immediately if the ignition key is inserted in the starter switch or the turn signal stalk is moved again.



Activating the exterior lighting with the remote control *

The welcome light function engages the dipped beam for a approx. 30 seconds.

This feature must be activated (once):

Unlock the vehicle, put the ignition key in the starter switch and press the light switch for approx. 5 seconds - see Fig. 14 136 S on next page.

To deactivate the function, contact a workshop.

To activate the welcome light function, press button  on the remote control twice, with the vehicle locked.

Country-specific version *:

To enable the welcome light function, press button  on the remote control once, with the vehicle locked.

This feature is deactivated immediately by pressing button  on the remote control or by switching on the ignition.



Instrument illumination , Information display illumination

Illuminates when ignition is switched on.

Brightness can be adjusted when the exterior lights are on:

Push to release knob  and then turn it clockwise or anticlockwise and hold until the desired brightness is obtained.

Display illumination * – see page 99.



Courtesy light



Automatic interior light

Illuminates automatically when the vehicle is unlocked with the remote control or when a door is opened.

Goes off automatically after a delay when the doors are closed or immediately when the ignition is switched on or the doors are locked.

Front courtesy light

Manual operation from inside, with doors closed:

- On = Press light switch 
- Off = Press light switch  again



Front reading lights *

Left and right reading lights are individually operable. With ignition on:

- On = Press button
- Off = Press button again

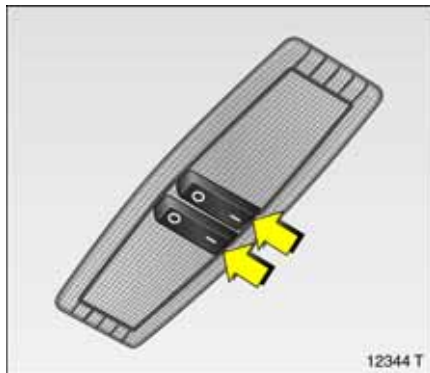

Courtesy lights, rear reading lights *

Centre switch position:

The rear courtesy light illuminates together with the front courtesy lights when a door is opened.

The rear reading lights on the left and right can be switched on separately.

With ignition on:

- On = Switch position I
- Off = Switch position 0

Entry lighting *

After unlocking the vehicle, the instrument panel and switch lighting plus the courtesy lights illuminate for a few seconds.

Illuminated mirror in the sunvisors *

The lighting switches on when the cover is opened.

Glove compartment lighting

Illuminates when ignition is on and the glove compartment lid is opened.

Cigarette lighter and ashtray illumination *

Illuminates when ignition is switched on.

Luggage compartment lighting

Illuminates when the luggage compartment is opened.

Automatically regulated centre console lighting *

Spotlight in housing of interior mirror.

Daylight-dependent, automatically regulated centre console lighting with ignition switched on.

Battery discharge protection *

Some consumers, such as the interior lighting switch themselves off after approx. 30 minutes if the ignition is off, in order to protect the battery charge.

Light covers

The inside of the light covers may briefly mist up under unfavourable wet / cold weather conditions, during heavy rain or after the vehicle has been washed. The misting disappears of its own accord after a short time, but can be accelerated by switching on the lights.

Headlights when driving abroad

The asymmetrical dipped beam increases the field of vision on the passenger's side of the lane.

This causes glare for oncoming traffic if the vehicle is driven in countries where traffic drives on the opposite side of the road.

Do as follows to prevent glare:

Vehicles with Halogen headlight system or Xenon headlight system *

Have a workshop convert the headlights.

Vehicles with Adaptive Forward Lighting (AFL) *

1. Pull stalk for main beam towards steering wheel and hold (headlight flash).
2. Switch on ignition.
3. After approx. 3 seconds, an acoustic signal sounds and the AFL control indicator  flashes for approx. 4 seconds.

After the change, AFL control indicator  flashes for approx. 4 seconds each time the ignition is switched on.

To return to asymmetrical dipped beam, pull the main beam stalk towards the steering wheel again and hold, switch on the ignition and wait for the acoustic signal. AFL control indicator  will then discontinue flashing.

Control indicator  – see page 109.

Infotainment System

Radio reception *	114
Infotainment system *	114
Remote control on steering wheel *	114
Twin Audio *	115
AUX input *	115
Electronic data acquisition in toll systems *	115
Mobile telephones and radio equipment *	116

Radio reception *

Vehicle radio reception differs from domestic radio reception:

As the vehicle antenna is relatively near the ground, the broadcasting companies cannot guarantee the same quality of reception as obtained with a domestic radio using an overhead antenna.

- Changes in distance from the transmitter,
 - multi-path reception due to reflection and
 - shadowing
- may cause hissing, noise, distortion or loss of reception altogether.

Infotainment system *

The Infotainment system is operated as described in the operating instructions.



Remote control on steering wheel *

The functions of the Infotainment system * and the information display can be operated via the buttons on the steering wheel.

Further information – see page 96 and the relevant operating instructions.



Twin Audio *

Twin Audio provides rear seat occupants with the opportunity to listen to a different audio source than the one selected by the driver on the Infotainment system.

Only an audio source that is not currently active on the Infotainment system can be controlled using Twin Audio.

Two headphone connections are available, with separate volume controls.

Further information is available in the Infotainment system operating instructions.

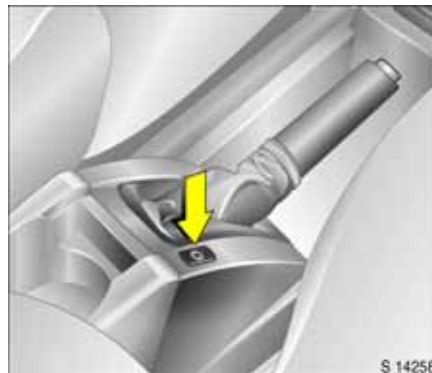

AUX input *

The AUX input is next to the handbrake in the centre console.

An external audio source, e.g. a portable CD player, can be connected via the AUX input.

Always keep the AUX input clean and dry.

Further information is available in the Infotainment system operating instructions.

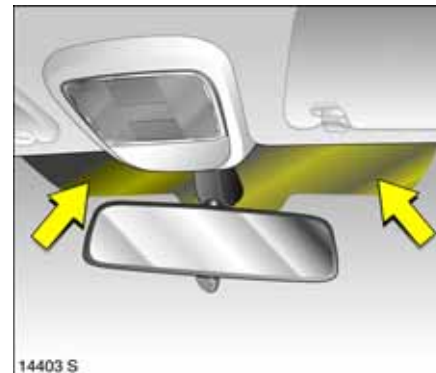

Electronic data acquisition in toll systems *

In vehicles with a heat-reflecting windscreen *¹⁾, attach chipcard * for electronic data acquisition and fee payment in black area of windscreen on left or right-hand side, behind the interior mirror. See markings in illustration. Attaching the chipcard outside this area may cause data acquisition malfunctions.

¹⁾ Solar Reflect.

Mobile telephones and radio equipment *

The Vauxhall installation instructions and the operating guidelines provided by the telephone manufacturer must be observed when fitting and operating a mobile telephone. Failure to do so could invalidate the vehicle's operating permit (EU Directive 95/54/EG).

Recommended conditions for fault-free operation:

- Professionally installed exterior antenna to obtain the maximum range possible.
- Maximum transmission power 10 Watt.
- Installation of the telephone in a suitable spot (see information on page 75).

Obtain advice on predetermined installation locations for the external antenna and equipment holder and ways of using devices with transmission power of more than 10 Watts.

We recommend that you consult your Vauxhall Authorised Repairer, who will have brackets and various installation kits available as accessories and will install them in accordance with regulations.

Operation of a hands-free device without external antenna, with mobile phone standard GSM 900/1800/1900 and UMTS, is permitted only if the maximum transmission power of the phone does not exceed 2 Watt for GSM 900 and otherwise 1 Watt. The instructions of the manufacturer of the telephone and hands-free device must be observed in all cases.

For reasons of safety, we recommend that you do not use the phone while driving. Even use of a hands-free set can be a distraction while driving. Be sure to observe any country-specific regulations.

Warning

Mobile phones and radios can cause malfunctions of the vehicle electronics when operated inside the vehicle without an external antenna, unless the instructions above are observed.

Mobile phones which do not comply with the above standards, and radios, may only be used with antennae installed on the outside of the vehicle.

Climate Control

Heating and ventilation system, air conditioning system *	117
Electronic Climate Control system *	117
Air vents	118
Heated rear window, heated exterior mirrors *	119
Heated seats *	119
Cooled glove compartment *	119
Heating and ventilation system	120
Air conditioning system *	123
Electronic Climate Control system *	126
Air intake	131
Air outlet	131
Pollen filter	131
Note	131
Maintenance	131



Heating and ventilation system, air conditioning system *

Ventilation, heating and cooling * are combined into one unit that is designed to provide comfort regardless of the season, weather or outside temperature.

When cooling * is activated, the air is cooled and dried.

The heating unit heats the air as required in all operating modes depending on the position of the temperature switch.

The air supply can be adjusted to suit requirements by means of the fan.

The buttons for cooling * and air recirculation are only found on model variants with an air conditioning system *.

Air conditioning system * - see page 123.



Electronic Climate Control system *

Offers the greatest comfort in the vehicle interior regardless of the conditions outside.

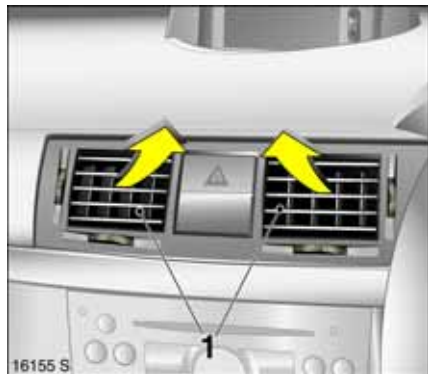

To ensure a uniform and comfortable climate in the vehicle, the temperature of inflowing air, airflow rate and air distribution are automatically adapted based on the climate conditions outside the vehicle and the current temperature of the vehicle interior.

Electronic Climate Control system * - see page 126.



Air vents

Pleasant ventilation to the head area controlled by the position of the temperature switch.

To increase the air supply, turn the fan all the way up and set the air distribution switch to  or .

Centre and side (1) air vents

To open air vent:

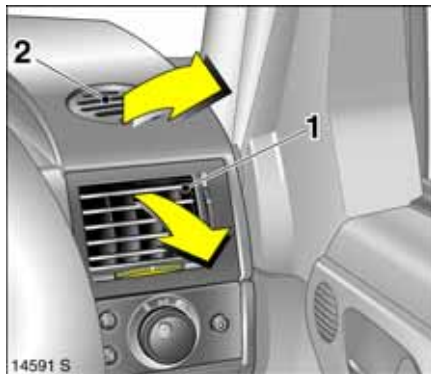

Turn vertical adjuster wheel up.

Adjust the direction of airflow by turning the horizontal and vertical adjuster wheels.



To close the air vents, turn the adjustment wheel fully downwards.

Windscreen defroster nozzles (2)

Air distribution switch set to  or :
Air is directed onto the windscreen and door windows.

Additional vents

Located beneath the windscreen and side windows and in the front footwell.

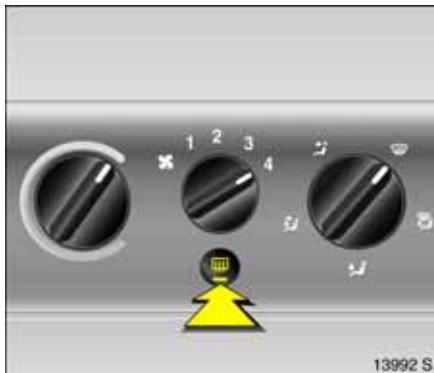

Heated rear window, heated exterior mirrors *

With the ignition on, the rear window and exterior mirror heating is switched on by pressing button .

LED  illuminated:

rear window and exterior mirror heating.

LED  not illuminated: rear window and exterior mirror heating is switched off.

Heating works with the engine running and is switched off automatically after approx. 15 minutes.

Depending on engine, cleaning the diesel particle filter * automatically switches on the heated rear window.



Heated seats *

Two pushbuttons  between the centre air vents.

When the ignition is switched on, the seat heating is activated by pushing the button .

LED illuminated: seat heating on.

LED not illuminated: seat heating off.

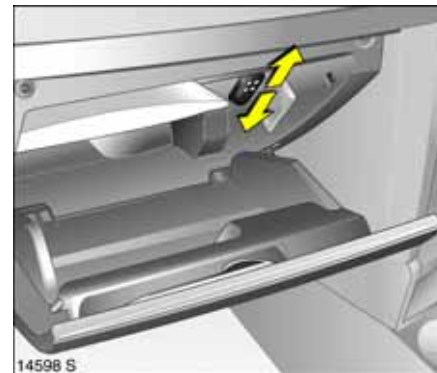

Cooled glove compartment *

Cool air is routed to the glove compartment.

If glove compartment cooling is not required, slide cover downwards.

General information and information on air intake, air outlet, pollen filter and maintenance,

see page 131.

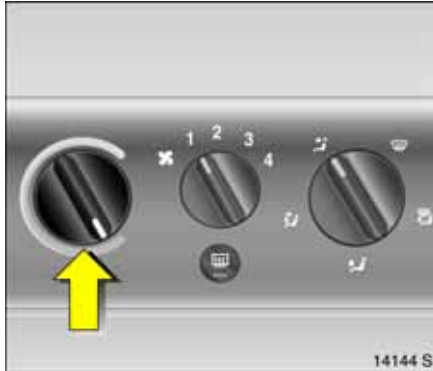

Heating and ventilation system

Left-hand rotary knob: Temperature

Red area = Warm
Blue area = Cold

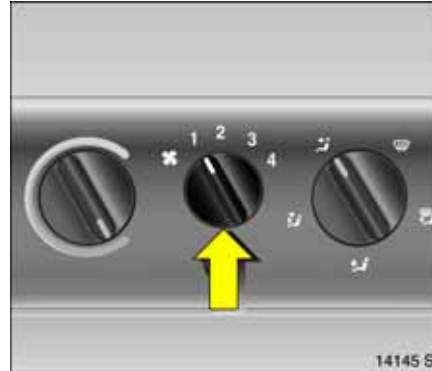

Centre rotary knob: Quantity of air

Four fan speeds:

☒ Off
4 Maximum rate of airflow

The rate of airflow is determined by the fan. The fan should therefore also be switched on during a journey.

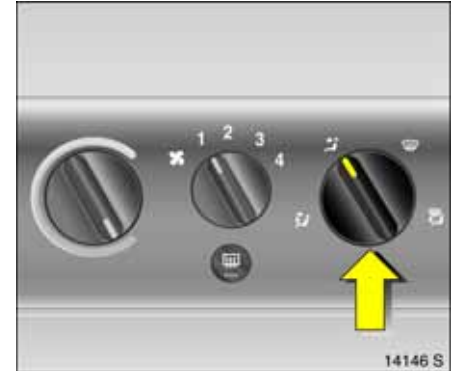



Right-hand rotary knob: Air distribution

- ☒ Towards windscreen and front door windows
- ☒ Towards windscreen, front door windows and footwell
- ☒ Towards footwell
- ☒ Towards head area and footwell
- ☒ Towards head area

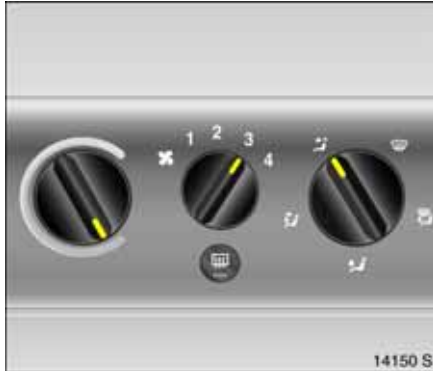
Open the air vents when the switch is set to ☒ or ☒.



Ventilation

- Set the temperature to the desired setting,
- Switch fan on, adjust fan setting as desired,
- For maximum ventilation in head area: set air distribution switch to  and open all air vents,
- For ventilation to footwell: Set air distribution switch to ,
- For simultaneous ventilation to the head area and the footwell: Set air distribution switch to .

Heating

The amount of heat is dependent on the coolant temperature and is thus not fully attained until the engine is warm.

For rapid warming of the passenger compartment:



- Turn the temperature switch clockwise as far as it will go.
- Set the fan to speed 3.
- Set air distribution switch to desired position, preferably position , see page 120.

Vehicles with Quickheat :

Depending on the outside temperature and the engine temperature, the passenger compartment is heated up more quickly using an auxiliary electric heater.

The auxiliary electric heater switches itself on automatically.

The comfort and general well-being of the vehicle occupants are to a large extent dependent on a suitable ventilation and heating setting.

To achieve stratification of temperature with a pleasant "cool head and warm feet" effect, set the rotary air distribution switch to ,  or , set temperature rotary knob to any position (in centre range with temperature stratification effect).



Heating the footwell

- Set the temperature switch to the red zone.
- Switch on fan.
- Set air distribution switch to .

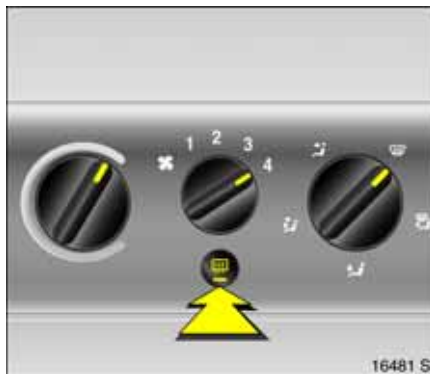



Demisting and defrosting windows

Warning

Disregard of these instructions could lead to misting or icing of the windows and subsequent accidents due to impaired visibility.

Misted or icy windows, such as in damp weather, from wet clothes or when outside temperatures are low:

- Turn the temperature switch clockwise as far as it will go (warm).

- Set fan to **3** or **4**.
- Set air distribution switch to .
- Switch on heated rear window .
- Open side air vents as required and direct them towards door windows.
- For simultaneous footwell heating, set air distribution switch to .

Air conditioning system *

As a supplement to the heating and ventilation system, the air conditioning system cools and dehumidifies (dries) inflowing air.

If cooling or dehumidification is not desired, switch off cooling in order to save fuel.

Cooling switches off automatically at low outside temperatures.



Cooling ☀

Operation only if engine is running and fan is switched on:

On = Press ☀
Off = Press ☀ again

Control indicator in the button.

When cooling (air conditioning compressor) is active, the air is cooled and dehumidified. If cooling or dehumidification is not desired, switch off cooling in order to save fuel.

Cooling switches off automatically at low outside temperatures.



Air recirculation system ↻

The air recirculation button ↻ is used to set the ventilation system to air recirculation mode (control indicator in button).

If fumes or unpleasant odours penetrate from outside: Temporarily switch on air recirculation system ↻.

To increase the cooling power at high outside temperatures, temporarily switch on the air recirculation system.







The air recirculation system minimises the entry of outside air and the air in the passenger compartment is recirculated. The humidity increases, and the windows can mist up. The quality of the passenger compartment air deteriorates which may cause the vehicle occupants to feel drowsy.

Air distribution to :

The air recirculation system is automatically switched off, to speed up window demisting and prevent fogging.



Comfort setting



- Set cooling  as desired.
- Air recirculation system  off.
- Set temperature switch as desired.
- Switch on fan to desired speed.
- Set air distribution switch to  or .
- Open or adjust air vents as required.

Temperature switch in centre of adjustment range: warmer air will flow into the footwell and cooler air into the upper zone, with warmer air coming from the side air vents and cooler air from the centre air vents.



Maximum cooling

Briefly open windows, sunroof and tilting roof  so that warm air can escape quickly.

- Cooling  on.
- Air recirculation system  on.
- Turn the temperature switch anticlockwise as far as it will go (cold).
- Set fan to 4.
- Set air distribution switch to .
- Open all air vents.









Demisting and defrosting windows

Warning

Disregard of these instructions could lead to misting or icing of the windows and subsequent accidents due to impaired visibility.

Misted or icy windows, such as in damp weather, from wet clothes or when outside temperatures are low:

- Cooling  on, the air conditioning compressor deactivates automatically when outside temperatures are low (icing),
- Turn the temperature switch clockwise,
- Set fan to 3 or 4,
- Air distribution switch to ; air recirculation system  automatically switches off,
 - or –
 if there is still moisture in the system after previous air conditioning operation, the windows may mist up. To prevent this, set air distribution to  before starting engine and set to  approx. 5 seconds after starting,
- Activate heated rear window ,
- Open side air vents as required and direct them towards the side windows.

Electronic Climate Control system *

Provides the greatest amount of comfort in the interior regardless of the weather, outside temperature or season.

To ensure a constant and comfortable climate in the vehicle, the temperature of the inflowing air, the airflow rate and the air distribution are changed automatically according to climatic conditions outside the vehicle.

The climate is regulated automatically based on personal settings.



16500 S

Temperature changes due to external influences, such as direct sunlight, are automatically compensated.

When cooling (air conditioning compressor) is active, air is cooled and dehumidified.

The pollen filter removes dust, soot, pollen and spores from the inflowing outside air.

When set to automatic mode, the Electronic Climate Control system provides the optimal settings for almost all conditions. If necessary, settings can be modified manually.

The Electronic Climate Control system is only operational when the engine is running.

Cooling (air conditioning compressor) switches off automatically at low outside temperatures.



Automatic mode

Basic setting for maximum comfort:

- Press **AUTO** button.
- Open all air vents.
- Air conditioning compressor activation – see page 129.
- Preset temperature to 22 °C with rotary knob.

The temperature can be set higher or lower as desired.

Switching off the air conditioning compressor (**ECO** appears in display) can have a detrimental effect on comfort and safety – see page 129.

All air vents are actuated automatically in automatic mode. The air vents should therefore always be open – see page 118.

Temperature preset

The left rotary knob can be used to set the temperature to values of between 16 °C and 28 °C.

For the sake of comfort, only change the preselected temperature in small steps.

Vehicles with Quickheat *:

Depending on the outside temperature and the engine temperature, the passenger compartment is heated up more quickly using an auxiliary electric heater.

The auxiliary electric heater switches itself on automatically.

If the temperature setting is less than 16 °C, **LO** appears in the air conditioning display: The Electronic Climate Control system runs constantly at maximum cooling power, and the temperature is not regulated.

If the temperature setting is above 28 °C, **HI** appears in the air conditioning display: The Electronic Climate Control system runs constantly at maximum heating power, and the temperature is not regulated.

Manual settings

Under certain circumstances (e.g. iced or misted windows), the functions of the Electronic Climate Control system can be modified manually.

Make manual settings as follows when necessary:





Window demisting and defrosting

Warning

Failure to follow the instructions could lead to misted or icy windows and accidents stemming from impaired visibility.

Misted or icy windows, such as in damp weather, from wet clothes or when outside temperatures are low:

Press button ,  appears in the air conditioning display.

The temperature, air distribution and fan are set automatically, windows are quickly demisted and de-iced.

To return to automatic mode:
Press button  or **AUTO**.

Heated rear window – see page 130.

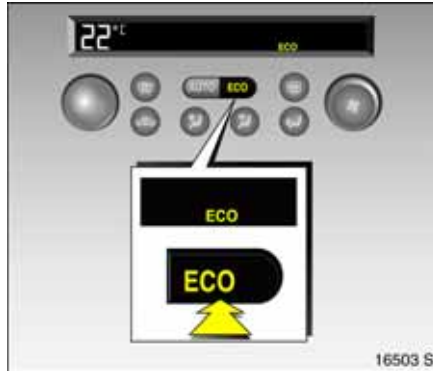

Activating and deactivating air conditioning compressor

Press the **ECO** button. **ECO** appears in the air conditioning display.

Switch on to save fuel. In this mode, the cooling (air conditioning compressor) is switched off.

Inflowing air is neither cooled nor dehumidified. This restricts the level of comfort provided by the Electronic Climate Control system. This may cause the windows to mist up, for example.

To return to cooling operation:
Press **ECO** button. **ECO** goes out.

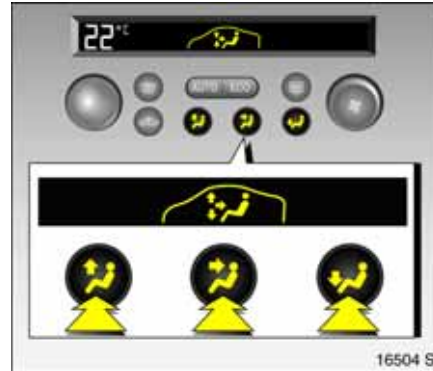

Air distribution

Press one or more of the following buttons. The corresponding symbol appears in the air conditioning display:

- ↖ Air distribution towards windscreen and front door windows.
- ↗ Air distribution towards vehicle occupants via adjustable air vents.
- ↘ Air distribution towards footwell.

To return to automatic mode:
Press the appropriate buttons again, or press **AUTO**.

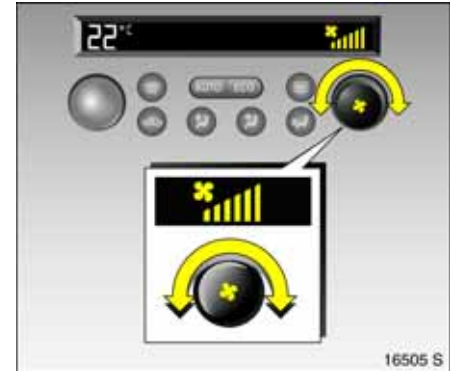

Airflow

Set airflow using the right-hand rotary knob. The selected fan speed is indicated by the number of bars.

To deactivate the fan and thereby the Electronic Climate Control system:
Turn the right-hand rotary knob anticlockwise until the display goes out.



Switching on: Turn rotary knob clockwise.

To return to automatic mode:
Press the **AUTO** button.



Manual air recirculation mode

The air recirculation system minimises the entry of outside air and the air in the passenger compartment is recirculated.

Press button ,  appears in the air conditioning display.

The exchange of fresh air is reduced in air recirculation mode. The quality of the passenger compartment air deteriorates which may cause the vehicle occupants to feel drowsy. In operation without cooling, the air humidity increases, so the windows may mist up. Consequently, the air recirculation system should only be run for short periods of time.

To switch off air recirculation:
Press button  again.

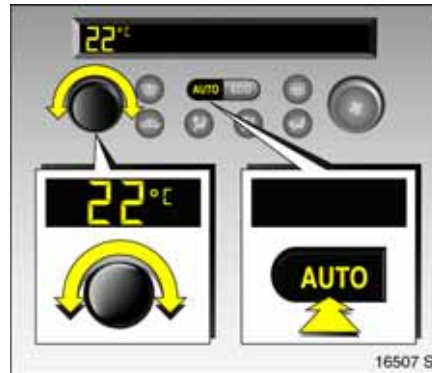

Air conditioning with the engine not running

When the vehicle is stopped and the ignition is off, the heat or cooling power still in the system can be used to condition the passenger compartment, for example when stopped at a level crossing.



Press **AUTO** with the ignition off. The preselected temperature appears in the air conditioning display. The temperature can be adjusted with the left-hand rotary knob.

The air conditioning will operate for a limited period of time.

To deactivate air conditioning:
Press the **AUTO** button.



Heated rear window, heated exterior mirrors*

With the ignition on, the rear window and exterior mirror heating is activated by pressing button , the air conditioning display shows .

The rear window and exterior mirrors will quickly be cleared of ice and condensation.

Heating works with the engine running and is switched off automatically after approx. 15 minutes.

Depending on engine, cleaning the diesel particle filter  automatically switches on the heated rear window.

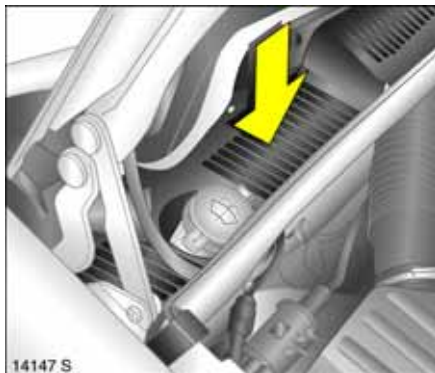

Air intake

The air intakes in front of the wind screen on the far right and left sides of the engine compartment must be kept clear to allow air intake. Remove any leaves, dirt or snow.

Air outlet

Do not cover the air outlets when stowing items in the luggage compartment storage compartments.

Pollen filter

The pollen filter cleans the air entering from outside and filters dust, soot, pollen and spores from the interior air if the air recirculation system * is active. The active carbon layer * eliminates most odours and harmful ambient gases from the air.

Have the pollen filter replaced at the intervals specified in the Service Booklet.

Note

If the windscreen is misted-up due to damp weather, temporarily set the system as described under "Window demisting and defrosting", see pages 122, 125.

Cooling * works most efficiently when the windows, sunroof and tilting roof * are closed. If the passenger compartment has heated up considerably after a long period in direct sunlight, briefly open the windows, sunroof and tilting roof * so that warm air can escape quickly.

When cooling * (air conditioning compressor) is switched on, condensation forms, which is expelled from the underside of the vehicle.

At least one air vent must be open while cooling * (air conditioning compressor) is on, in order to prevent the evaporator from icing up due to lack of air movement.

Cooling switches off automatically at low outside temperatures.

For trouble-free operation of the Electronic Climate Control system *, do not cover the sensor located between the air vents beneath the windscreen.

Maintenance

For consistently good operation, the air conditioning compressor * must be switched on for several minutes once per month, regardless of the weather and the time of year. Operation with the air conditioning compressor switched on * is not possible at low outside temperatures.

For faults, contact a workshop.

Driving and Operation

Easytronic *	132
Driving hints	138
Saving fuel, protecting the environment	140
Fuel consumption	142
Fuel	142
Fuel filler cap	143
Refuelling	143
Catalytic converter, exhaust gases	145
Drive Control Systems	149
Brake system	154
Anti-lock Brake System (ABS)	156
Wheels, tyres	158
Roof racks *	163
Towing equipment *	163
Towing equipment with removable coupling ball bar *	163
Caravan / trailer towing	166

Easytronic *

The semi-automatic Easytronic * transmission permits manual (Manual mode) or automatic (Automatic mode) gearshifting, both with automatic clutch control.

Warning

Disregard of these instructions may lead to injuries or endanger life.



Transmission display

Shows the mode or current gear.



Starting the engine

When starting the engine, apply the footbrake at the same time. The engine can only be started in position **N** and with the footbrake applied. The transmission display shows "N".

If the footbrake is not applied, the control indicator (⚡) in the instrument cluster illuminates and "N" flashes in the transmission display; the engine cannot be started.

Also the vehicle cannot be started if all brake lights have failed.

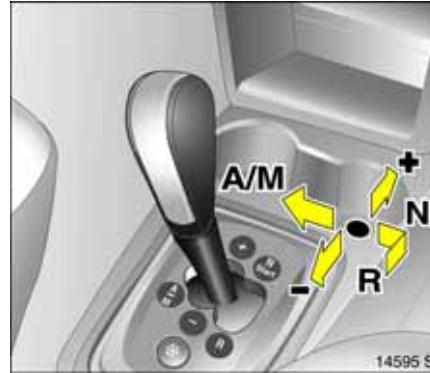

Easytronic operation via the selector lever

Always move the selector lever all the way to the stop. Note the gear or mode indicator in the transmission display.

Move selector lever toward N
Neutral.

Selector lever in ● (centre position)

Once the selector lever has been moved from **N** to position ● (centre position) with the footbrake applied, the Easytronic is in Automatic mode and first gear has been selected (second gear with winter programme enabled). "A" appears in the transmission display.

When the footbrake is released, the vehicle starts to "creep". If the footbrake is not applied, "A" flashes. Start off by pressing the accelerator immediately or move selector lever back to **N** and repeat procedure with footbrake applied.

Shifting to different gears takes place automatically in Automatic mode, depending on the driving conditions.

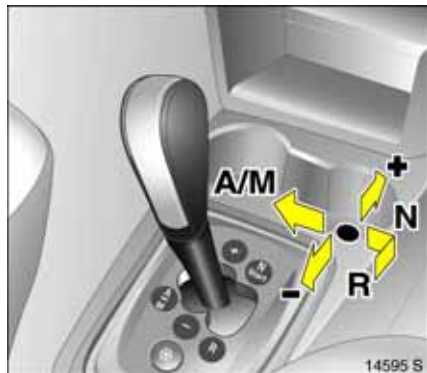

Selector lever in A/M

Switch between Automatic and Manual mode.

In Manual mode, gears can be selected manually by moving the selector lever to **+** or **-**. The current gear is indicated in the transmission display.

If the engine speed is too low, the Easytronic will automatically shift to a lower gear even in Manual mode. This prevents the engine from stalling.

Selector lever in + or -

- +** Shift to a higher gear.
- Shift to a lower gear.

If a higher gear is selected when the running speed is too low, or a lower gear when the speed is too high, no shift is effected. This prevents the engine from running at too low or too high revs.

Gears can be skipped by jogging the selector lever repeatedly at short intervals.

When the vehicle is in Automatic mode, Easytronic shifts to Manual mode by moving the selector lever to position **+** or **-**. The current gear is indicated in the transmission display.

Selector lever in R

Reverse gear. Engage only when vehicle is stationary.

Press button on selector lever, select **R**. The transmission display shows "R".

If **R** is selected when the vehicle is in motion, "R" flashes in the transmission display and no gear is engaged.

Electronically controlled driving programmes in Automatic mode

- By means of delayed gear changing (higher engine speeds) following a cold start, the operating temperature programme quickly and automatically brings the catalytic converter to the temperature required for optimum pollutant reduction.
- Adaptive programmes automatically adapt gearshifting to suit the driving conditions, such as if the vehicle is towing a caravan / trailer, has a high payload, or is being driven on inclines.



Winter programme ❄️

In the event of difficulties starting-off on slippery roads, press button ❄️ ("A" and ❄️ appear in the transmission display). Easytronic switches to Automatic mode and the vehicle sets off in second gear.

The winter programme is switched off by:

- Pressing button ❄️ again,
- Switching to Manual mode,
- Turning off the ignition.

In order to protect the Easytronic, the winter programme automatically switches itself off at extremely high clutch temperatures.

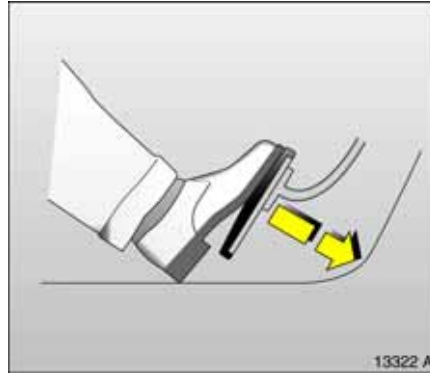

Kickdown

Accelerator pedal pressed past the pressure point: below certain speeds, the transmission shifts down into a lower gear. Full engine power is available for acceleration.

During kickdown, no manual gearshifting is possible.

When the engine speed approaches its upper limit, the transmission shifts to a higher gear during kickdown, even in Manual mode.

Without kickdown, this automatic shift is not effected in Manual mode.

Braking assistance from engine

Automatic mode:

When driving downhill, Easytronic does not shift into higher gears until a fairly high engine speed has been reached. When braking, Easytronic shifts down in good time.

Manual mode:

To utilise the engine braking effect, select a lower gear in good time when driving downhill.

"Rocking" the vehicle

If it becomes necessary to rock the vehicle to free it from sand, mud, snow or a hole, move the selector lever between ● (centre position) and R in a repeat pattern while applying light pressure to the accelerator pedal. Do not race the engine and avoid sudden acceleration.

This applies only to the exceptional circumstances mentioned above.



Manoeuvring the vehicle

For accurate manoeuvring when parking, at garage entrances etc., the creeping movement can be utilised by releasing the footbrake with a gear selected.

Never actuate an accelerator and brake pedals simultaneously.

In order to prevent damage, the Easytronic disengages the "creep function" at extremely high automatic clutch temperatures.

Stopping the vehicle

In Automatic or Manual mode, when the vehicle has stopped, first gear (with Winter mode engaged, second gear) is engaged automatically and the clutch released.

In R, reverse remains engaged.

If a warning signal sounds when the driver's door is opened (footbrake not applied), move the selector lever to N and apply the handbrake.

When stopping on gradients, apply the handbrake or footbrake. To prevent overheating of the clutch, do not increase engine speed, to ensure smooth idling when in gear.

To prevent damage to the Easytronic, the clutch is closed automatically at high clutch temperatures.

Switch off engine if stopping for a lengthy period, e.g. in traffic jams or at level crossings.

Vehicle storage

Before leaving the vehicle:

- Apply handbrake,
- Remove ignition key.

The most recently engaged gear (indicator in transmission display) remains engaged. With N, no gear is engaged.

When the ignition is switched off, the Easytronic no longer responds to movement of the selector lever.

If the ignition key is not removed, the battery may be discharged if the vehicle is then left to stand for a lengthy period of time.

If the handbrake has not been applied, control indicator (C) flashes for a few seconds after the ignition is switched off.



Fault

If a fault occurs in the Easytronic, control indicator  illuminates. In the event of serious faults, "F" also appears in the transmission display.

It is possible to continue driving if only control indicator  illuminates. Manual mode can then no longer be selected.

If "F" also appears in the transmission display, it is not possible to continue driving.

Have the cause of the fault eliminated by a workshop. The self-diagnosis integrated into the system allows rapid fault identification.

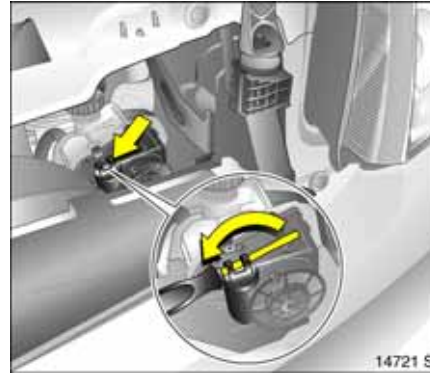

Interruption of power supply

The clutch is not disengaged if the vehicle battery is discharged and a gear has been selected. The vehicle cannot move.

If the battery is flat, start the vehicle using jump leads – see page 172.

If the cause of the power failure is not a discharged battery, contact a workshop. If the vehicle must be removed from flowing traffic, release the clutch as follows:

1. Apply handbrake and switch off ignition.
2. Open bonnet and engage support.

3. Clean Easytronic around the cap (see illustration in previous column) so that no dirt can get into the opening when the cap is removed.
4. Rotate cap to slacken and remove by lifting upwards – see illustration in previous column.
5. Turn the adjusting screw clockwise using a flat-head screwdriver (vehicle tools * – see page 176) until clear resistance can be felt. The clutch has now been disengaged.

Do not turn beyond the resistance, since this can damage the Easytronic.

6. Fit cleaned cap again. The cap must be in full contact with the housing.

Towing the vehicle and starting the engine is not permitted when the clutch has been released in this way, although the vehicle can be moved a short distance.

Contact a workshop immediately.

Driving hints

The first 600 miles (1000 km)

Drive your vehicle at various speeds.

Do not use full throttle. Never allow the engine to labour at low revs.

Make good use of all gears.

Depress the accelerator pedal a maximum of approx. three quarters of the available pedal travel in all gears.

Do not drive faster than three quarters of maximum speed.

Do not brake unnecessarily hard for the first 125 miles (200 km).

Never coast with engine not running

Many units will not function in this situation (e.g. brake servo unit, Electric Power Steering (EPS) ✱). Driving in this manner is a danger to yourself and others.

Brake servo unit

When the engine is not running, the brake servo unit is no longer effective once the footbrake has been depressed once or twice. Braking effect is not reduced, but significantly greater force is required for braking.

Electric Power Steering (EPS) ✱

If the Electric Power Steering fails when being towed with the engine switched off, the vehicle can still be steered, but considerably more force is required.

Driving in mountainous terrain or with a caravan / trailer

The cooling fan is electrically operated. Its cooling power is therefore independent of the engine speed.

Since a considerable amount of heat is generated at high engine speeds and less at slower speeds, do not shift down when climbing hills while the vehicle is still coping with the gradient in the higher gear.

Driving with a roof load

Do not exceed the permissible roof load, see page 214. For reasons of safety, distribute the load evenly and secure it properly with retaining straps.

Adjust tyre pressure to load conditions.

Do not drive faster than 75 mph (120 km/h). Check and retighten the straps frequently. Observe country-specific regulations.

Switching off the engine

When you switch off, fans in the engine compartment may continue running for a time to cool the engine.

If the engine temperature is very high, e.g. after driving in mountainous terrain: Allow the engine to idle for approx. two minutes in order to prevent heat accumulation.

Vehicles with turbocharged engine:

After running at high engine speeds or high engine loads, operate the engine briefly at a low load or run in neutral for approx. 30 seconds before switching off, in order to protect the turbocharger.

Save energy – more miles / kilometres

Please observe the running-in hints on the previous page and the tips for energy saving on the following pages.

Good, technically correct and economical driving ensures maximum durability and performance for your vehicle.

Overrun

The fuel supply is automatically shut off during overrun, e.g. when the vehicle is being driven down long gradients or when braking. To enable the overrun cut-off to take effect, do not accelerate during overrun and on manual vehicles, do not release the clutch. To prevent damage to the catalytic converter, overrun cut-off is temporarily deactivated when the catalytic converter temperature is high.

Vehicles with turbocharged engine:

Flow-generated noises may be audible if the accelerator is released quickly, on account of airflow in the turbocharger.

Engine speed

Drive in a low engine speed range for each gear as much as possible.

Warming up

Allow the engine to warm up while driving. Do not warm it up by letting it run at idling speed. Do not apply full throttle until the engine has reached operating temperature.

After a cold start, the Easytronic * does not switch to higher gears until the speed increases when it is in Automatic mode.

This allows the catalytic converter to quickly reach the temperature that is required for optimum emission reduction.

Correct gear selection

Do not race your engine while the transmission is in neutral or with a low gear selected. Driving too fast in individual gears as well as stop-and-go traffic increases engine wear and fuel consumption.

Change down

When decreasing speed, shift down into the next lowest gear. Do not slip the clutch with a high-revving engine. This is especially important when hill climbing.

Clutch operation

Always depress the clutch pedal hard to the floor to prevent shifting difficulties and transmission damage.

When driving, do not use the pedal as a footrest; this will cause substantial clutch wear.

Cooling fan

The cooling fan is controlled via a thermostat and therefore only runs if necessary.

Depending on engine, cleaning the diesel particle filter * automatically switches on the cooling fan.

Pedals

Do not place any objects in the footwell which could slip under the pedals and inhibit the pedal travel.

To ensure the pedal travel is uninhibited, there must be no mats in the area of the pedals.

Battery care

When driving slowly or when the vehicle is stationary, e.g. in slow urban traffic, stop-and-go traffic or traffic jams, turn off all unnecessary electrical loads where possible (e.g. heated rear window, heated front seats, etc.).

Decouple when starting, in order to relieve the strain on the starter and the battery.

Saving fuel, protecting the environment

Trend-setting technology

In the development and manufacture of your vehicle, environment-friendly and in the main recyclable materials were used. The production methods used to make your vehicle are likewise environmentally-compatible.

Recycling of production wastes keeps the circulation of material closed. Reduction of energy and water requirements also helps to conserve natural resources.

A highly advanced design means that your vehicle can be easily disassembled at the end of its working life, and the individual materials separated for subsequent re-use.

Materials such as asbestos and cadmium are not used. The refrigerant in the air conditioning system * is CFC-free.

New painting techniques employ water as a solvent.

End-of-Life vehicle recovery

For detailed information on Vauxhall's on-going commitment to achieving an environmentally sustainable future, including; design for recycling, take back of End-of-Life Vehicles (ELVs) and the recycling of ELVs, view www.vauxhall.co.uk/recycling for details.

Energy and environment-conscious driving

■ High noise levels and exhaust emissions are often a result of driving without due attention to saving energy and protecting the environment.

■ You should therefore drive with energy in mind "more miles / kilometres – less fuel". Reduce the noise level and exhaust emissions by adopting an environment-conscious driving style. This is extremely worthwhile and improves the quality of life.

Fuel consumption depends to a great extent on your own personal driving style. The following hints are intended to help you consume fuel at a rate that is as close as possible to the specified levels – see page 212.

Check your vehicle's fuel consumption every time you refuel. This facilitates early detection of any irregularities causing increased fuel consumption.

Warming up

■ Full throttle and warming up at idle speed increase wear, fuel consumption, exhaust emission, the amount of pollutant in the exhaust and the amount of noise.

■ Drive off immediately after starting. Warm up the engine by running it at moderate engine speeds.

Uniform speed

■ Hectic driving significantly increases fuel consumption, the exhaust emissions, the proportion of pollutant in the exhaust gas and the noise level.

■ Do not accelerate and brake unnecessarily. Drive at uniform speed, watching the road.

Avoid frequent starting-off and stopping e.g. at traffic lights, in short distance traffic and in queues of traffic by means of clever planning. Select roads with good traffic flow.

Idling

■ The engine also consumes fuel when idling.

■ If you have to wait for more than one minute, it is worthwhile switching off the engine. Five minutes of idling corresponds to approximately 0.6 miles (one kilometre) of driving.

Overrun

- The fuel supply is automatically shut off during overrun, e.g. when the vehicle is being driven down long gradients or when braking – see page 139.
- To enable the overrun cut-off to come into action and save fuel, do not accelerate or declutch during overrun.

Correct gear selection

- High revs increase engine wear and fuel consumption.
- Do not race your engine. Avoid driving at high engine speeds.

Making use of the tachometer helps to save fuel. Drive in a low engine speed range for each gear as much as possible with uniform engine speeds. Drive as often as possible in top gear, select the next higher gear as soon as possible, and only change down when the engine is no longer running perfectly smoothly.

High speed

- The higher the speed, the higher the consumption and the noise level. At top speed, you consume a great deal of fuel and produce excessive noise and exhaust emissions.

- Slightly releasing the accelerator pedal results in distinct fuel savings with no major loss of speed.

Drive at no more than approx. three quarters of maximum speed and you will use up to 50% less fuel, without losing a great deal of time.

Tyre pressure

- Inadequate tyre pressure, leading to higher road resistance, costs money in two ways: for more fuel and increased tyre wear.
- Regular checks (every 14 days) pay off.

Electrical loads

- The power consumption of electrical equipment increases fuel consumption.
- Switch off all auxiliary electrical loads (e.g. air conditioning ❄, heated rear window) when not needed.

Roof racks, ski-holders

- Due to air resistance, a roof load can increase fuel consumption by approx. 3.5 gal./1000 miles (1 l/100km).
- Remove them if they are not being used.

Repair and maintenance

- Improper repairs or adjustment and maintenance work can increase fuel consumption. Do not carry out work on the engine yourself.

You may, out of ignorance, infringe environmental laws by not disposing of materials properly.

Appropriate parts might not be recycled.

Contact with some of the materials involved may pose a health hazard.

- We recommend that repair and maintenance be entrusted to your Vauxhall Authorised Repairer.

Extreme driving conditions

- Going up steep slopes, cornering, driving on poor roads and winter driving all increase fuel consumption.

Fuel consumption increases dramatically in urban traffic and at winter temperatures, especially on short trips when the engine operating temperature is not reached.

- Follow the hints given above to keep consumption to a minimum under such conditions.

Fuel consumption

Fuel consumption is determined under specific driving conditions – see page 212.

Special equipment increases the weight of the vehicle. As a result, they can increase fuel consumption and reduce the specified maximum speed.

For the first few thousand miles / kilometres, friction between the engine and transmission components is higher. This increases fuel consumption.

Fuel

Fuel for petrol engines

Normal commercial high-quality fuels with a maximum ethanol content of 5% in accordance with DIN EN 228 are suitable (for catalytic converter see page 145, for octane numbers see page 208). The quality thereof has considerable effect on the performance, running and service life of the engine. The additives mixed with the fuel are extremely important. For this reason you must only refuel with high-quality fuels containing additives.

Fuels with ethanol content greater than 5% do not comply with DIN EN 228 and must not be used unless the vehicle has been specifically developed and approved for these fuels.

Fuel with too low an octane number can cause pinking. Vauxhall cannot be held liable for resulting damage.

Petrol with a higher octane number can always be used.

Do not use 91 octane petrol in vehicles with the Z 16 LET¹⁾ engine.

The ignition timing is automatically adjusted according to the grade of fuel used (octane number) – see page 208.

Use of petrol with an octane rating of 95 will ensure economical driving.

For vehicles with Z 16 LET¹⁾ engine, use of 95 RON fuel reduces performance and torque.

Fuel for diesel engines

Diesel engines must be operated only on commercially available diesel fuel meeting the specifications of DIN EN 590.

Since January 2004, some oil companies have mixed their diesel fuel with up to 5% Bio fuel (FAME = Fatty Acid Methyl Esters) like RME (Rape-Oil Methyl Ester). This is in accordance with the current DIN EN 590 and does not harm the fuel injection system. The characteristics of a diesel fuel mixed up with 5% Bio fuel (FAME) do not differ from conventional diesel fuel and do not influence the vehicle's driveability.

Important: Diesel fuel mixed with 5% FAME according to DIN EN 590 must not be confused with 100% Bio Diesel, which is not to be used in Vauxhall engines.

The flow and filterability of diesel fuel are temperature-dependent.

Diesel fuels with improved low temperature properties are therefore available on the market during the winter months. Make sure that you fill the tank with winter fuel before the start of the cold weather season.

Additives can be used with diesel fuels with winter properties that are guaranteed by the manufacturer and when using diesel fuel filters that are heated depending on the outside temperature.

Diesel fuels must not be diluted with fuels that are intended for petrol engines.

¹⁾ Sales designation – see page 208.

Fuel filler cap

When replacing the fuel filler cap, be sure to use a genuine fuel filler cap for your model to ensure full functionality. Diesel-engined vehicles have special fuel filler caps.

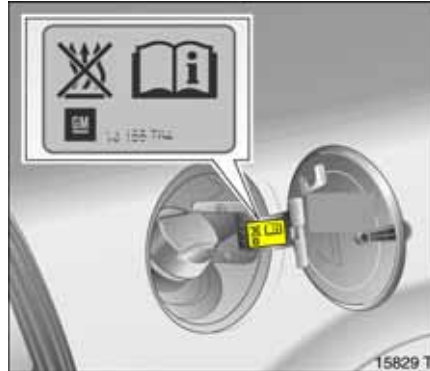

Refuelling

Warning

Care must be taken when handling fuel.

Before refuelling, turn off engine and also shut off external heaters with combustion chambers (identified by stickers on fuel filler cap). Switch off mobile phones.

Warning

Fuel is flammable and explosive. When handling fuel or when in the immediate vicinity, avoid naked flames or sparks. Do not smoke. This also applies where the presence of fuel is revealed by its characteristic smell. If fuel odours occur in the vehicle, have a workshop eliminate the fault immediately.

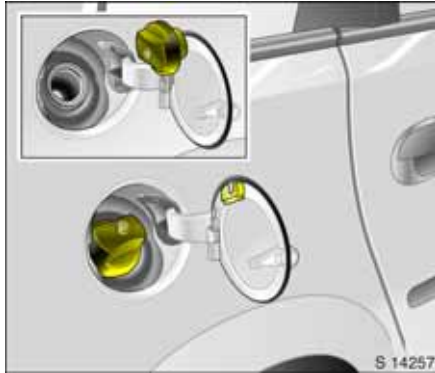

Fuel filler neck at right rear side of vehicle.

The tank flap is locked together with the doors – see page 30.

Open the tank flap.

To open, unscrew the fuel filler cap, remove and suspend from the tank flap.

The fuel tank has a limiting system which prevents overfilling of the tank.

Correct filling depends to a large extent on proper operation of the fuel dispensing pump:

1. Fully insert the pump nozzle and switch it on.
2. At the automatic switch-off, the specified tank capacity is reached by means of metered refuelling (twice). Insert fuel dispensing pump as far as possible.

To close, place fuel filler cap in position and turn, overcoming the resistance until the ratchet on the cap engages audibly.

Close tank flap.

Wipe off any overflowing fuel immediately.

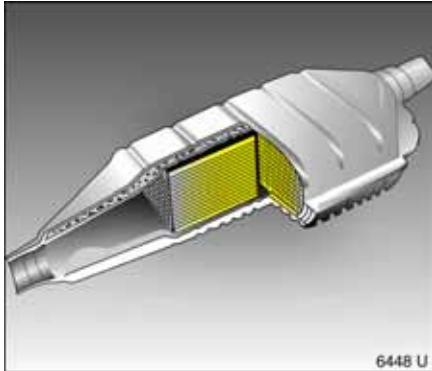

Catalytic converter, exhaust gases

Catalytic converter for petrol engines

Leaded fuel will damage the catalytic converter and parts of the electronic system, rendering them inoperative.

Use of high-quality fuels other than those specified on page 142 (e.g. LRP¹⁾) could damage the catalytic converter.

Damage to the catalytic converter or the vehicle may result if the following points are not observed:



- On ignition faults, uneven running after cold start, a clear drop-off in engine power or other unusual operating symptoms which could indicate a fault in the ignition system, contact a workshop immediately. Continue driving if necessary for a short time at low speed and low revs.

Irregular engine running and a loss of engine power when the Electronic Stability Programme ESP^{Plus}* comes into action are due to the operating conditions and are therefore of no significance - see page 149.

- If unburned fuel enters the catalytic converter, this may result in overheating and irreparable damage to the catalytic converter.

You should therefore avoid unnecessarily long use of the starter when starting-off, running the tank dry (an irregular fuel supply will lead to overheating) and starting the engine by pushing or towing.

¹⁾ LRP = Lead Replacement Petrol.

- If the control indicator  flashes to indicate emissions, back off until the flashing stops and the control indicator illuminates. Contact a workshop immediately. Control indicator for emissions , see page 147.

Catalytic converter for diesel engines

Damage to the catalytic converter or the vehicle may result if the following points are not observed:

- On uneven running, a clear drop-off in engine power or other unusual operating symptoms, contact a workshop immediately. Continue driving if necessary for a short time at low speed and low revs.

Irregular engine running and a loss of engine power when the Electronic Stability Programme ESP^{Plus}  comes into action are due to the operating conditions and are therefore of no significance - see page 149.



Controlling exhaust emission

Some of the damaging substances in the exhaust such as carbon monoxide (CO), hydrocarbons (HC) and nitrous oxides (NO_x) are reduced to a minimum by making structural changes – mainly in the injection system and the ignition system in conjunction with the catalytic converter.



Control indicator  for exhaust

Illuminates when the ignition is switched on and during the start attempt. Goes off shortly after the engine starts running.

Illuminated with the engine running indicates a fault in the exhaust gas cleaning system. The permitted emissions may be exceeded. Contact a workshop immediately.

Flashing with the engine running indicates a fault which could lead to catalytic converter damage. You may continue driving without damage if you back off until the flashing stops and the control indicator illuminates steadily. Contact a workshop immediately.





Control indicator  for engine electronics

Illuminates for a few seconds after the ignition is turned on.

If it illuminates when the engine is running, there is a fault in engine or transmission electronics. The electronic system switches to an emergency running programme. Fuel consumption may be increased and the driveability of the vehicle may be impaired.

In some cases, faults can be eliminated by switching off the engine and restarting. If the control indicator illuminates again when the engine is running, contact a workshop to eliminate the cause of the fault.

If it illuminates briefly, but does not recur, it is of no significance.

Illumination of control indicator  can indicate water in the diesel fuel filter . Check diesel fuel filter for possible water residue, see page 230.

If it flashes after the ignition is switched on, there is a fault in the immobiliser system. The engine cannot be started – see page 27.

Exhaust gases

Warning

Engine exhaust gases contain poisonous carbon monoxide, which is colourless and odourless and could be fatal if inhaled.

If exhaust gases penetrate the vehicle interior, open a window and contact a workshop.

During the first drive, smoke may develop because of wax and oil evaporating on the exhaust system. Park the vehicle in the open for a while after the first drive and avoid inhaling the fumes.

Diesel particle filter

The diesel particle filter system filters harmful soot particles out of the exhaust gases.

The system contains a self-cleaning function at set intervals. The filter is cleaned by burning the soot particles at high temperature. This process is automatic in certain driving conditions and can take up to 25 minutes. During this time, fuel consumption may be increased. Some odour and smoke are normal.

Under certain driving conditions, e.g. short journeys, the system may not clean itself automatically.

If control indicator  flashes, drive on and as soon as road and traffic conditions allow, increase the speed to over 25 mph (40 km/h) to start the diesel particle filter cleaning. Cleaning is quickest at high speeds and under load. The engine speed should not fall below 2000 rpm. The control indicator goes out as soon as cleaning is complete.

We recommend not switching off the ignition during cleaning.

Maintenance

Have all maintenance work carried out at the intervals specified. We recommend that you entrust this work to your Vauxhall Authorised Repairer, who has proper equipment and trained personnel available. Electronic testing systems permit rapid diagnosis and remedy of faults. This way you can be certain that all components of the vehicle's electrical, injection and ignition systems operate correctly, that your vehicle has a low level of pollutant emission and that the catalytic converter system will have a long service life.

You are thereby making an important contribution towards keeping the air clean and compliance with emissions legislation.

Checking and adjustment of the fuel-injection and ignition systems is part of the scope of a Service. For this reason you should have all maintenance work carried out at the intervals specified in your Service Booklet.

Drive Control Systems

Electronic Stability Programme (ESP® Plus) *

ESP® Plus improves driving stability as necessary in any driving situation regardless of the type of road surface or tyre grip. It also prevents the drive wheels from spinning.

The system monitors vehicle movements. As soon as the vehicle starts to swerve (understeers / oversteers) engine output is reduced (the sound of the engine changes) and individual wheels are specifically braked. This considerably improves the driving stability of the vehicle on snow and ice and on wet or slippery road surfaces.

ESP® Plus is ready for operation as soon as the ignition is switched on and control indicator  goes out.

When ESP® Plus comes into action, control indicator  flashes.

The vehicle is now in a critical situation; ESP® Plus allows you to keep control of the vehicle and reminds you to match your speed to the road conditions.

Warning

Do not let this special safety feature tempt you into taking risks when driving. Traffic safety can only be achieved by adopting a responsible driving style.

Control indicator

Illuminates for a few seconds after the ignition is turned on. The system is ready for operation when the control indicator goes out.

Flashes while driving:

This shows that the system has come into action. The engine output may be reduced (the sound of the engine changes) and the vehicle may be braked automatically to a small degree.



Illuminates while driving:

Fault in the system. Driving can be continued. Poor road surface conditions may however still cause vehicle stability to be impaired.

Have the cause of the fault eliminated. Self-diagnosis integrated into the system allows rapid fault identification.

Illuminates after interruption of power supply e.g. after disconnecting battery.

After a power supply interruption, the steering angle sensor must be calibrated to make the system operational:

- Automatic calibration driving in a straight line at a constant slow speed (12 to 25 mph (20 to 40 km/h)) on a level, dry road.
- Manual calibration by turning steering wheel from limit position to limit position.

If the control indicator does not go off after successful calibration, observe notes in middle column.

Cruise control *

Cruise control can store and maintain speeds of approx. 20 to 125 mph (30 to 200 km/h). Deviation from the stored speed is possible on uphill or downhill inclines.

For safety reasons, the cruise control cannot be activated until the footbrake has been applied once.

The cruise control is operated with the buttons **I**, **R** and **O** on the turn signal stalk.

Do not use cruise control if it is not advisable to maintain a constant speed (e.g. in situations presenting a danger to yourself and other road users, in heavy traffic or on winding, slippery or greasy roads).

With Easytronic *, only use cruise control when in Automatic mode.

When the cruise control is active, reaction times may be increased due to the different position of the feet.

⚠ Warning
Even with cruise control activated, the driver has full responsibility for maintaining an appropriate speed. Disregard of these instructions could lead to injury or danger to life.

**Control indicator **

Illuminates for a few seconds when the ignition is switched on. The system is now ready for operation.

When driving, control indicator  will illuminate as soon as the system is switched on.

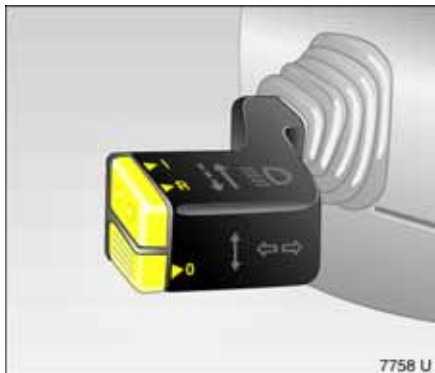

To activate:

Tap button **I**:

The current speed is stored and maintained. The accelerator pedal can be released.

Vehicle speed can be increased by depressing the accelerator pedal. When the accelerator pedal is released, the previously stored speed is resumed.

Accelerate:

With cruise control active, hold down button **I** or tap it repeatedly: the speed is increased continuously or in steps of 1.2 mph (2 km/h) without using the accelerator pedal.

The current speed is stored and saved after the **I** button has been released.

Decelerate:

With cruise control active, hold down button **R** or briefly press it repeatedly: speed is reduced continuously or in steps of 1.2 mph (2 km/h).

The current speed is stored and saved after the **R** button has been released.

To deactivate:

Tap button **O**:

Cruise control is switched off.

The vehicle slowly decelerates. To continue driving, depress the accelerator pedal in the usual way.

For reasons of safety, cruise control deactivates under certain driving conditions.

For example:

- if the vehicle's speed drops below approx. 20 mph (30 km/h) or,
- if the footbrake is depressed or,
- if the clutch pedal is depressed or,
- if Easytronic * selector lever in **N**.

Resuming the stored speed:

Tap button **R** at a speed above 20 mph (30 km/h): the speed selected before the cruise control was switched off is resumed.

The stored speed value is deleted when the ignition is switched off.

Parking distance sensors *

Parking distance sensors make reverse parking easier by measuring the distance between the rear of the vehicle and an obstacle through ultrasonic reflection, and by warning you with an acoustic signal in the passenger compartment.

The system records the distance using four sensors in the rear bumper.

To activate:

The parking distance sensors activate automatically when the ignition is switched on and reverse gear is engaged.

Operational readiness is indicated by a brief tone.

If the vehicle slowly gets close to an obstacle while reversing, an intermittent acoustic signal is audible in the passenger compartment when the vehicle tail is less than one metre from the obstacle. The interval between the signals becomes shorter as the distance is reduced. If the distance is less than 30 cm, a continuous signal is audible.

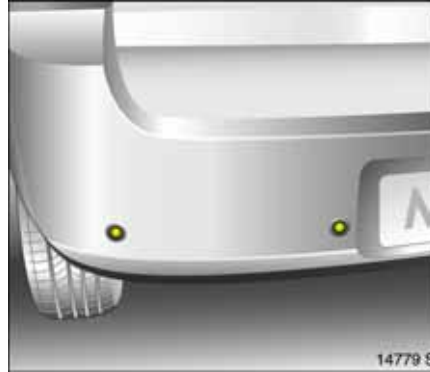

⚠ Warning

Under certain circumstances, various reflective surfaces on objects or clothing as well as external noise sources may cause the system to fail to detect obstacles. For this reason, care must be taken when reversing even if the parking distance sensors are operational. This is of particular importance when in the vicinity of pedestrians.

To deactivate:

The system deactivates automatically when reverse gear is disengaged.

Towing equipment,caravan / trailer towing:

If a towing device is subsequently fitted to the vehicle, the system must be set to the modified vehicle length by a workshop.

When operating without a trailer, the tow bar must be removed, else the system can be damaged.

Fitting rear load racks *

Rear load racks, e.g. bicycle racks, fitted near the sensors could disrupt the system.

Fault:

On system faults, a permanent tone sounds at a distance of 1 metre from the obstacle. Have the cause of the fault eliminated by a workshop.

In order to avoid operational problems or erroneous information, the sensors must be undamaged and free of soiling, snow and ice.

Brake system

The effectiveness of the brakes is an important factor for traffic safety.

To improve effectiveness, do not brake unnecessarily hard for the first 125 miles (200 km) after new brake pads have been fitted.

Brake pad wear must not exceed a specified limit. Regular maintenance as detailed in the Service Booklet is therefore of the utmost importance for traffic safety.

Have worn brake pads replaced by a workshop.

Tested and approved pads give optimum braking performance.

Brake pads worn to the minimum level cause grinding noises. You may continue to drive but have the pads replaced as soon as possible. To change the pads, contact a workshop.

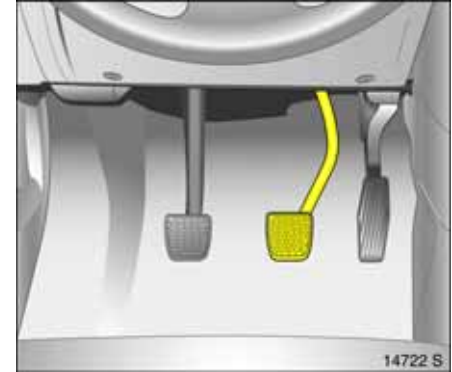

Brake assist

If the footbrake is operated with a powerful push, the vehicle is automatically braked at full braking power in order to achieve the shortest possible braking distance when full-on braking occurs (braking assistant).

Maintain steady pressure on the footbrake for as long as full-on braking is to continue. When the footbrake is released, the maximum brake force amplification is taken away.

Adaptive brake lights *

During full-on braking, all three brake lights flash for the duration of ABS control.

Footbrake

The footbrake comprises two independent brake circuits.

If one brake circuit faults, the vehicle can still be braked with the other brake circuit. However the braking effect will occur at a lower pedal position and considerably more force is required. The braking distance is longer. Contact a workshop before continuing to drive.

To ensure that full pedal travel can be utilized, especially in case of a fault in one of the brake circuits, there must be no mats in the vicinity of the pedals – see page 139.

When the engine is not running, the assistance of the brake servo unit disappears once the footbrake has been depressed once or twice. Braking effect is not reduced, but braking requires significantly greater force. This is especially important to bear in mind when towing.

Check the brake lights before starting out on a journey.

Shortly after starting each journey, the effectiveness of the brake system should be tested at low speeds and without inconveniencing other traffic, especially if the brakes are wet, e.g. after the vehicle has been washed.

The brake fluid level should be checked regularly. If the brake fluid level is too low and the handbrake is not applied, control indicator (D) illuminates in the instrument cluster – see page 87.

Hill Start Assist * (HSA)

The system helps pull away on inclines.

After releasing the footbrake, if the handbrake is not applied, the brakes are only released after 2 seconds. As soon as the acceleration is sufficient to prevent rolling back, the brake is released.



S 14256

Handbrake

Always apply handbrake firmly. On slopes, apply the handbrake as firmly as possible.

The mechanical handbrake acts on the brakes on the rear wheels. It engages automatically when applied.

To release the handbrake, pull the lever up slightly, press the ratchet knob, and fully lower the lever.

To reduce the operating forces of the handbrake, apply the footbrake at the same time.



Brake system control indicator (ⓘ)

The control indicator illuminates after the ignition is turned on, when the handbrake is applied or if the brake or clutch fluid level is too low. Brake fluid – see page 232.

Warning

If the control indicator illuminates when the handbrake is released, stop driving immediately. Contact a workshop.

For vehicles with Easytronic*, the control indicator flashes for a few seconds when the ignition is turned off, if the handbrake is not applied.

Warning

If the control indicator illuminates when the handbrake is released, stop driving immediately. Contact a workshop.

Anti-lock Brake System (ABS)

ABS continuously monitors the vehicle's brake system and prevents the wheels from locking regardless of the road condition and tyre grip.

It starts to regulate the braking pressure as soon as a wheel shows a tendency to lock. The vehicle remains steerable, even in the event of very heavy braking, for instance on bends or when swerving to avoid an obstacle. Even in the case of full-on braking, the ABS makes it possible to drive round an obstacle without releasing the brakes.

ABS control is made apparent through a pulse in the footbrake and the noise of the regulation process.

Warning

For optimum braking, keep the footbrake fully depressed throughout the braking process, despite the fact that the pedal is pulsating. Do not reduce the pressure on the pedal.

Do not let this special safety feature tempt you into taking risks when driving.

Traffic safety can only be achieved by adopting a responsible driving style.



Control indicator (ABS) for ABS

The control indicator illuminates for a few seconds after the ignition is turned on. The system is ready for operation when the control indicator goes out.

If the control indicator does not go out after a few seconds, or if it illuminates while driving, there is a fault in the ABS. The brake system remains operational without ABS regulation.

Self-check

Each time the ignition is turned on and the engine is started, after driving at a speed of approx. 2 mph (3 km/h), the system performs a self-check which may be audible.

Fault

Warning

If there is a fault in ABS, the wheels may be subject to locking due to braking that is heavier than normal. The advantages of ABS are no longer operational.

You can continue driving, provided you drive with care and anticipation.

Have the cause of the fault eliminated by a workshop. The self-diagnosis integrated into the system allows rapid fault identification.

Wheels, tyres

See page 216 for suitable tyres and restrictions.

Tyres fitted in the factory are adapted to the chassis and provide optimum driving comfort and safety.

Changing tyre / wheel type

Before changing to other tyres or wheels, note the necessary changes.

If tyres of a different size than those fitted at the factory are used, the electronic speedometer may require reprogramming to ensure that the correct speed is displayed.

 **Warning**

Use of unsuitable tyres or wheels may lead to accidents and render the vehicle unroadworthy.

Fitting new tyres

Fit tyres in pairs or in sets, which is even better. Ensure that tyres on one axle are:

- the same size,
- the same design,
- the same make,
- and have the same tread pattern.

Fit directional tyres such that they roll in the direction of travel. The rolling direction is indicated by a symbol (e.g. an arrow) on the sidewall.

Tyres fitted opposing the rolling direction (such as when changing a tyre) should be refitted as soon as possible. This is the only way to benefit fully from the design properties of the tyre.

When disposing of tyres, follow the legal requirements.

Certain brands of tyre have a beaded edge to protect alloy wheels from damage. If wheel trims are used on steel wheels with beaded-edge tyres, the following procedure must be followed:

- Use wheel trims and tyres that are approved by Vauxhall for the vehicle in question and therefore meet all the requirements pertaining to the respective wheel / tyre combination.
- If the wheel trims and tyres used are not Vauxhall-approved, the tyres must not have a beaded edge.

 **Warning**

Use of unsuitable tyres or wheel trims could lead to sudden loss of air and thereby accidents.

Tyre pressure

Check tyre pressure, including the spare wheel, at least every 14 days and prior to any long journey; the tyres should be checked when cold. Don't forget to check the spare ✱.

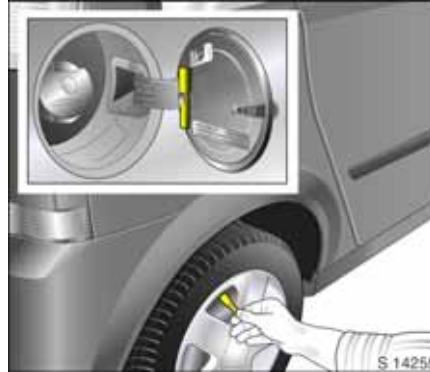

Use the valve cap key to make unscrewing the valve caps easier. The key is located on the inside of the tank flap.

Tyre pressure, see page 216.

Do not reduce tyre pressure when the tyres are warm. Otherwise the pressure may drop below the permissible minimum when the tyres cool down.

After having checked the tyre pressures, tighten the valve caps using the valve cap key.

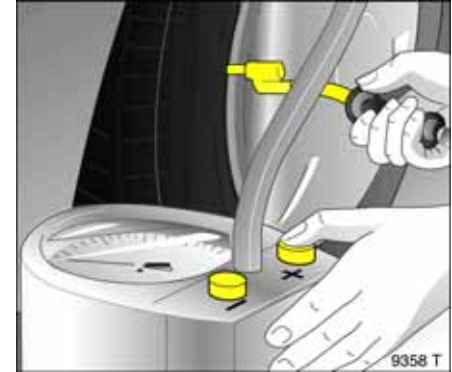

Incorrect inflation pressures will impair safety, vehicle handling, comfort and fuel economy and will increase tyre wear.

If the pressure is too low, this can result in considerable tyre heating and internal damage, leading to tread separation and even tyre blow-out at high speeds.

Hidden tyre damage is not eliminated by adjusting the inflation pressure.

⚠ Warning

Incorrect tyre pressure could lead to a flat tyre.

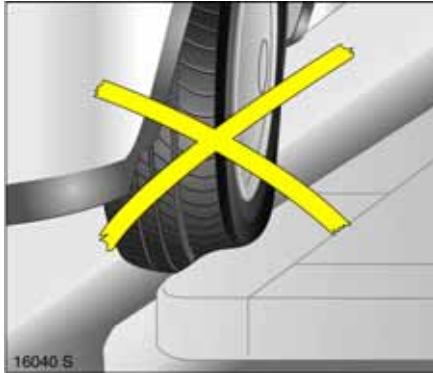

Tyre condition, wheel condition

Drive over edges slowly and at a right angle if possible. Driving over sharp edges can lead to hidden tyre damage and wheel damage which is only noticed later on.

When parking, ensure that the tyres are not pressed against the edge of the kerb.

Check tyres regularly for damage (penetrated foreign bodies, punctures, cuts, cracks, bulges in side walls). Check wheels for damage. If damage or unusual wear is found, contact a workshop.

⚠ Warning

Damage may lead to tyre blow-out.

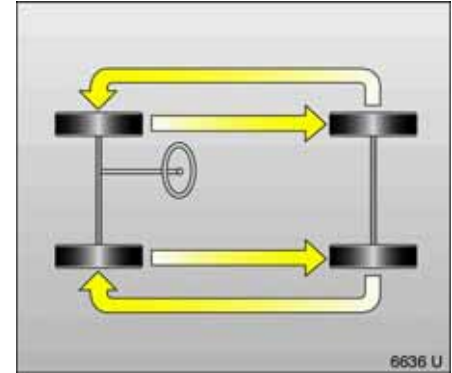

Tread depth

Check tread depth regularly.

If wear is greater in the front than in the rear, switch the front and rear tyres.

Correct the tyre pressures.

For reasons of safety, tyres should be replaced when their tread depth has worn down to 2 to 3 mm (winter tyres: 4 mm).



The legally permissible minimum tread depth (1.6 mm) has been reached when the tread has worn down as far as one of the tread wear indicators (TWI¹⁾). A number of tread wear indicators are spaced at equal intervals around the tyre within the tread. Their position is indicated by markings on the tyre sidewall.

General information

- The risk of aquaplaning is greater if the tyres are worn.
- Tyres age, even if they are used only very little or not at all. A spare wheel which has not been used for six years should be used with care.
- Never fit used tyres the previous history and use of which you do not know.
- So as not to impair brake cooling, use only wheel trims approved for use on your vehicle.

Tyre designations

Meaning:

e.g. **175/70 R 14 88 T**

- 175** = Tyre width in mm
- 70** = Cross-section ratio (tyre depth to width in %)
- R** = Belt type Radial
- 14** = Wheel diameter in inch
- 88** = Load index
e.g. 88 corresponds to 567 kg
- T** = Speed code letter

Speed code letters:

- Q** up to 100 mph (160 km/h)
- S** up to 112 mph (180 km/h)
- T** up to 118 mph (190 km/h)
- H** up to 130 mph (210 km/h)
- V** up to 150 mph (240 km/h)
- W** up to 168 mph (270 km/h)

¹⁾ **TWI** = Tread Wear Indicator.

Winter tyres ❄️

For notes on fitting new tyres – see page 158.

See page 216 for restrictions.

Winter tyres (M + S tyres) improve safety at temperatures below 7 °C and should therefore be fitted on all the wheels.

The design of summer tyres means they have limited qualities for winter driving.

If the maximum permissible speed for the winter tyres is less than that of the vehicle, a notice indicating the maximum permissible speed for the tyres must be affixed within the driver's field of vision¹⁾.

If you use the spare wheel when it is fitted with a summer tyre, the vehicle's driveability may be affected, especially on slippery road surfaces. Obtain a replacement for the faulty tyre as soon as possible, and have the wheel balanced and fitted to the vehicle.

Wheel covers ❄️

If the wheel trims and tyres used are not Vauxhall-approved, make sure that the tyres do not have a beaded edge – see page 158.



Tyre chains ❄️

Limitations and further information – see page 216.

Tyre chains are only permitted on the drive wheels (front axle). They must be fitted to the tyres symmetrically in order to achieve a concentric fit.

Always use fine mesh chains that add no more than 10 mm to the tyre tread and the inboard sides (including chain lock).

Wheel trims on steel wheels could come into contact with parts of the chain and be damaged. Remove the wheel trim – see page 178.

Tyre chains may only be used at speeds up to 30 mph (50 km/h) and, when travelling on roads that are free of snow, they may be used for brief periods only since they are subject to rapid wear on a hard road and may snap.

Temporary spare wheel ❄️:

Tyre chains must not be used on the temporary spare wheel. If you need to use tyre chains after suffering a flat front tyre, fit the temporary spare on the rear axle and transfer one of the rear wheels to the front axle.

For notes on the temporary spare wheel – see pages 178, 216.

Changing wheels – see page 178.

¹⁾ Varies from country to country on account of national regulations.

Roof racks ***⚠ Warning**

Disregard of these notes can lead to injuries which may be fatal. Vehicle passengers must be informed accordingly.

For safety reasons and to avoid roof damage, we recommend using the Vauxhall roof rack system approved for your vehicle.

Disengage covers concealing roof rack mounts by pushing sliders in direction of arrow (e.g. with coin) and remove. To close roof rack mounts, insert covers at front and engage sliders at rear.

Fasten the roof rack following the instructions that accompany the system.

Driving hints – see page 138.

Towing equipment ***⚠ Warning**

Disregard of these notes can lead to injuries which may be fatal. Vehicle passengers must be informed accordingly.

Only use a trailer towing device approved for the vehicle. Have a towing device fitted by workshop, who will inform you of any possible trailer load increases. They will have the instructions for fitting the device and any necessary changes to the vehicle concerning cooling, heat shields or other devices.

⚠ Warning

The coupling ball bar is to be removed when not towing.

Mounting dimensions of towing equipment * – see page 222.

**Towing equipment with removable coupling ball bar *****Stowage of coupling ball bar**

The coupling ball bar is located in a bag with the vehicle tools housed under the spare wheel - see illustration above.

Spare wheel * - see page 177.

On vehicles with a tyre repair kit *, the coupling ball bar is located in the left stowage compartment beneath the floor cover in the luggage compartment - see page 166, Fig. 17923 S.

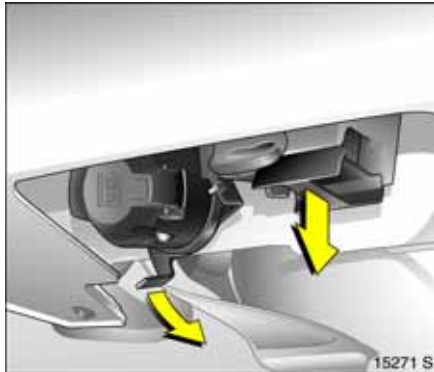

Fitting the coupling ball bar

Fold down the socket. Remove the sealing plug from the hole for the coupling ball bar and stow it in the luggage compartment.

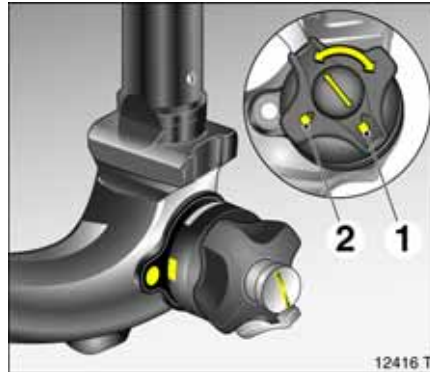

Checking the tensioning of the coupling ball bar:

- Red marking on turn knob points towards white marking on coupling ball bar.
- Gap of approx. 4 mm between turn knob and coupling ball bar.
- Key is in lock at position 1.

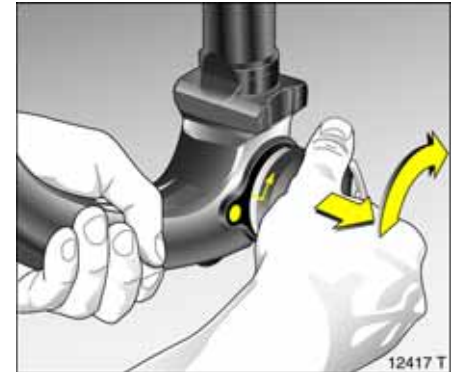

Otherwise, the coupling ball bar must be tensioned before it is inserted into the coupling housing:

- Unlock coupling ball bar (key to position 1) – see Fig. 12416 T.
- Pull tum knob out and turn it forwards as far as it will go – see illustration above.



Inserting the coupling ball bar:

Insert the tensioned coupling ball bar into the coupling housing and push firmly upwards until the coupling ball bar engages in position.

The turn knob snaps back into its home position resting against the coupling ball bar.

Warning

Do not touch the turn knob when inserting the coupling ball bar - risk of injury.

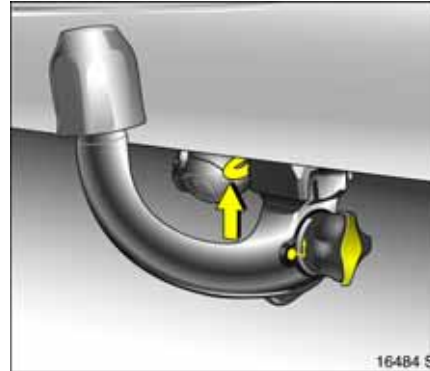

Lock coupling ball bar (key to position 2 – see page 164, Fig. 12416 T). Remove key and press protective flap into position.

When the coupling ball bar is locked, the turn knob can no longer be pulled out.

Important

Check that the coupling ball bar is correctly installed:

- Green marking on turn knob points towards white marking on coupling ball bar.
- No gap between turn knob and coupling ball bar.
- Coupling ball bar must be seated firmly in coupling housing.
- Coupling ball bar must be locked and key must be removed.

Warning

Towing is permitted only with a correctly fitted towbar. If the towbar cannot be fitted correctly, contact a workshop.

Eye for break-away stopping cable

For trailers with brakes, attach break-away stopping cable to rear towing eye – see arrow in Fig. 16484 S.

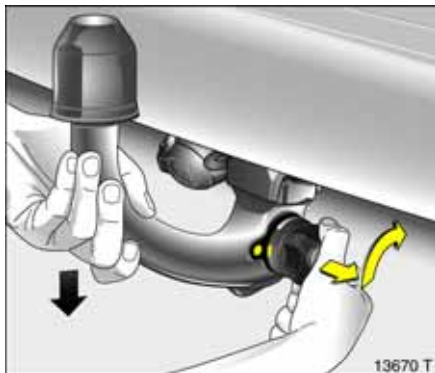

Dismounting the coupling ball bar

Unlock coupling ball bar (key to position 1 – see page 164, Fig. 12416 T).

Pull turn knob out and turn it forwards as far as it will go. Remove coupling ball bar downwards out of coupling housing.

Fold away the socket – see page 164, Fig. 15271 S.

Insert the sealing plug in the hole for the coupling ball bar.

Do not use steam-jet cleaners or other high-pressure cleaners to clean the coupling ball bar.

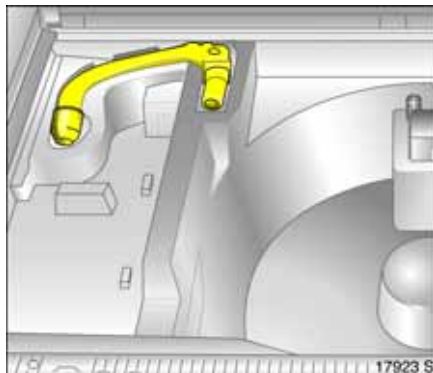

Stowage of coupling ball bar

Place coupling ball bar in bag, as shown on page 163 in Fig. 14195 S, and attach next to vehicle tools, beneath the spare wheel.

On vehicles with a tyre repair kit*, the coupling ball bar is stored in the left stowage compartment beneath the floor cover in the luggage compartment - see illustration above.

Caravan / trailer towing

Caravan and trailer loads¹⁾

The permissible caravan / trailer loads are vehicle-dependent and engine-dependent maximum values which must not be exceeded. The actual caravan / trailer load is the difference between the actual gross weight of the caravan / trailer and the actual coupling socket load with the caravan / trailer coupled.

When the caravan / trailer load is being checked, therefore, only the caravan / trailer wheels – and not the jockey wheel – must be standing on the weighing apparatus.

The permissible caravan / trailer loads for your vehicle are specified in the vehicle documents. Unless otherwise specified, they are valid for gradients up to max. 12%.

¹⁾ Observe national regulations.

The permissible caravan / trailer load should be fully utilised only by drivers who are adequately experienced in towing large or heavy caravans / trailers.

The permitted caravan / trailer load applies up to the specified incline and up to an altitude of 1000 metres above sea-level. Since engine power decreases as altitude increases because of the air becoming thinner, therefore reducing climbing ability, the permitted towing weight also decreases by 10% for every 1000 metres of additional altitude. The towing weight does not have to be reduced when driving on roads with slight inclines (less than 8%, e.g. motorways).

The actual caravan / trailer load plus the actual gross weight of the towing vehicle must not exceed the maximum permitted towing weight. For example, if the permitted Gross Vehicle Weight is utilised, the caravan / trailer load must only be used until the maximum permitted towing weight is reached. The maximum permitted towing weight is shown on the identification plate – see page 206.

Coupling socket load

The coupling socket load is the load exerted by the caravan / trailer on the coupling ball. It can be varied by changing the weight distribution when loading the caravan / trailer.

The maximum permissible coupling socket load (55 kg) of the towing vehicle is specified on the towing equipment identification plate and in the vehicle documents. This must always be complied with, particularly in the case of heavy caravans / trailers. The coupling socket load should be no less than 25 kg.

When measuring the coupling socket load, make sure that the drawbar of the loaded caravan / trailer is at the same height as it will be when the caravan / trailer is coupled with the towing vehicle loaded. Particularly important for caravans / trailers with tandem axle.

Rear axle load during towing

With the caravan / trailer connected and the towing vehicle fully loaded, including all occupants, the permitted rear axle load (specified on identification plate and vehicle documents) may be exceeded by no more than 25 kg, and the maximum permitted Gross Vehicle Weight by no more than 30 kg.

If the maximum permitted rear axle load is exceeded, a maximum speed of 60 mph (100 km/h) applies, and 50 mph (80 km/h) for commercial vehicles. Slower national maximum speed limits for towed vehicles must be complied with.



Tyre pressure

On the towing vehicle, increase the tyre pressure to the value given for full load – see page 216. Also check tyre pressures of the trailer wheels and the spare wheel ❄.

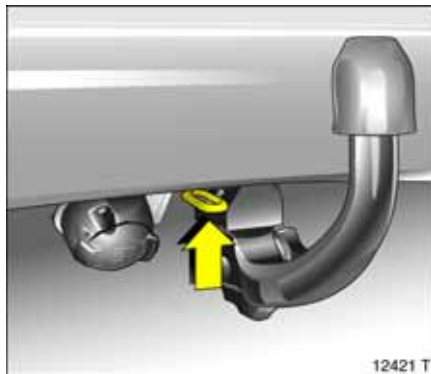

Driving characteristics, towing tips

In the case of caravans / trailers with brakes, attach the break-away stopping cable to the eye (arrow in illustration).

Before attaching the caravan / trailer, lubricate the ball of the caravan / trailer towing device. However, do not lubricate the ball if a stabiliser, which acts on the coupling ball, is being used to damp snaking.

Check caravan / trailer lighting before starting to drive. The fog tail light on the vehicle is deactivated when towing a caravan or trailer.

Caravan / trailers with LED turn signals must have a provision that makes it possible to monitor standard light bulbs.

Turn signal control indicator - see page 86.

Handling is greatly influenced by the loading of the caravan / trailer. Loads should therefore be secured so that they cannot slip, and should be placed in the centre of the caravan / trailer if possible, i.e. above the axle.

In the case of caravans / trailers with low driving stability, do not exceed a speed of 50 mph (80 km/h); the use of a friction-type stabiliser is strongly recommended.

Do not drive faster than 50 mph (80 km/h) if possible, even in countries where higher speeds are permitted.

Make sure that you have enough room when cornering and avoid sudden manoeuvres.

If the caravan / trailer starts to sway, drive more slowly, do not attempt to correct the steering and brake sharply if necessary.

If it is necessary to apply the brakes fully, depress the footbrake as hard as possible.

Remember that the braking distance for vehicles towing caravans / trailers with and without brakes is always greater than that for vehicles not towing a caravan / trailer.

When driving downhill, the brakes are under considerably more load when towing a caravan / trailer. For this reason, drive in the same gear as if driving uphill and drive at a similar speed.

In Automatic mode, the Easytronic * automatically selects the drive programme with optimum engine braking effect.

The cooling fan is electrically operated. Its cooling power is therefore independent of the engine speed.

Since a considerable amount of heat is generated at high engine speeds and less at slower speeds, do not shift down when climbing hills while the vehicle is still coping with the gradient in the higher gear.

Diesel engines: On gradients of 10% or more, do not drive faster than 20 mph (30 km/h) in first gear or 30 mph (50 km/h) in second gear.

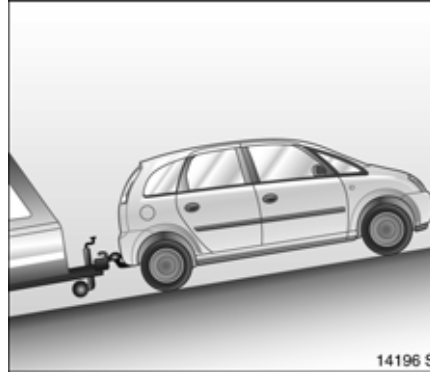



Starting on inclines

For vehicles with manual transmission, the most favourable engine speed when starting-off on an incline is between 2500 and 3000 rpm for petrol engines and between 2000 and 2500 rpm for diesel engines. Hold engine speed constant, engage clutch gradually (let slip), release handbrake and open throttle. If possible, the engine speed should not drop during this procedure.

For vehicles with Easytronic * in Automatic mode, simply apply full gas.

Before starting-off under extreme conditions (high combination weight, mountainous terrain with steep inclines), switch off all unnecessary electrical loads (e.g. heated rear window, air conditioning system *, heated front seats *).

Self-help, Vehicle Care

Diesel fuel system, bleeding	170
Bonnet	170
Starting	171
Starting the engine with jump leads *	172
Towing the vehicle.....	173
Towing another vehicle.....	175
Warning triangle  *	
First-aid kit  *.....	176
Jack  and vehicle tools *.....	176
Spare wheel *.....	177
Changing wheels	178
Tyre repair kit *.....	182
Electrical system	186
Fuses and the most important circuits they protect.....	188
Bulb replacement	190
Halogen headlight system.....	191
Halogen headlight system *, Adaptive Forward Lighting (AFL) *	193
Xenon headlight system	193
Parking lights	195
Front turn signal lights	196
Front fog lights *.....	196
Tail lights	197
Number plate light.....	198
Courtesy lights	200
Vehicle care.....	202

Warning

Disregard of these notes can lead to injuries which may be fatal. Vehicle passengers must be informed accordingly.

Diesel fuel system, bleeding

Never let the tank run dry!

If control indicator  illuminates, refuel as soon as possible. Refuel immediately if it flashes.

Restarting after running out of fuel is possible, but starting behaviour will be delayed. Turn on the ignition three times for 15 seconds each time. Then start the engine for a maximum of 40 seconds¹⁾. If it does not start, repeat the process after waiting at least 5 seconds. If the engine still does not start, contact a workshop.

¹⁾ With engine Z 17 DTH:
For technical reasons, only possible for 30 seconds. Sales designation - see page 209.

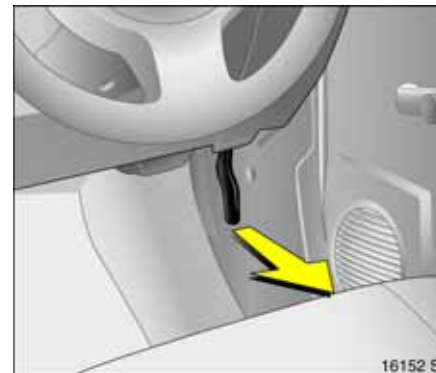

Bonnet

To open the bonnet, pull the release lever located on the driver's side below the instrument panel. The bonnet will then be unlocked and will partially open. Return release lever to its original position.

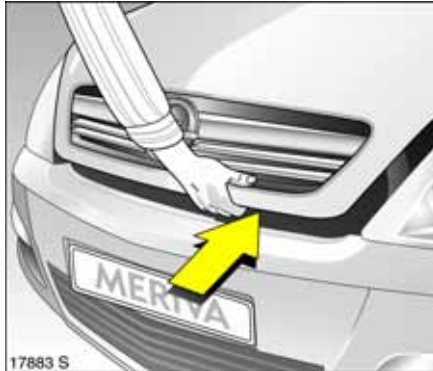

A release lever is located behind the radiator grille just right of centre – as viewed from the front.

To open, pull lever and raise bonnet.

Any dirt or snow on the bonnet can slide down towards the windscreen when the bonnet is opened and block the air intake – see page 131.

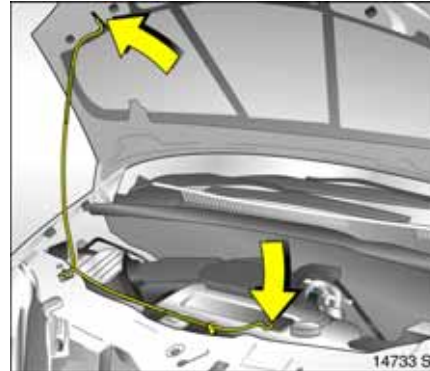

To hold the bonnet in the open position, insert the support rod located at right angles above the radiator grille into the small slot in the underside of the bonnet.

Before closing bonnet, press support rod firmly into its retainer. Lower the bonnet gradually and then allow it to fall into the lock under its own weight.

Check that the bonnet is locked in position by pulling at its front edge. If it is not engaged, repeat the procedure.

Starting

Do not start with quick charger

This prevents damage to electronic components.

Do not start by pushing or towing

Because your vehicle is fitted with a catalytic converter, it must not be started by pushing or towing – see page 145.

The vehicle can only be started using jump leads – see following page.

Starting the engine with jump leads *

A vehicle with a discharged battery can be started using jump leads and the battery of another vehicle.

Attempts to start the vehicle should be made at intervals of one minute and should not last longer than 15 seconds.

Warning

Be extremely careful when starting with jump leads. Any deviation from the following instructions can lead to injuries or damage caused by battery explosion or damage to the electrical systems of both vehicles.

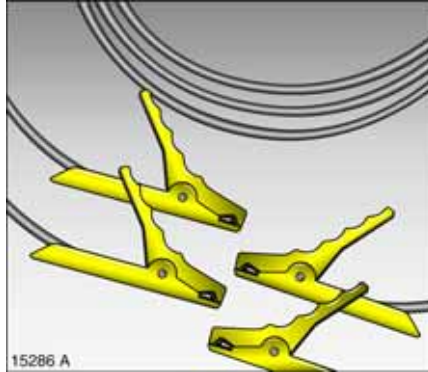

- Never expose the battery to naked flames or sparks.
- A discharged battery can freeze at a temperature of approx. 0 °C. Always thaw a frozen battery in a warm room before connecting jump leads.
- Do not allow battery fluid to come into contact with eyes, skin, fabrics or painted surfaces. The fluid contains sulphuric acid which can cause injuries and damage in the event of direct contact.
- Wear eye protection and protective clothing when handling a battery.
- Use auxiliary battery with same voltage (12 volts). Its capacity (Ah) must not be considerably less than that of the discharged battery. Voltage and capacity information can be found on the batteries.
- Use jump leads with insulated terminals and a cross section of at least 16 mm² (25 mm² for diesel engines).
- Do not disconnect the discharged battery from the vehicle.
- Switch off all unnecessary electrical consumers.
- Do not lean over the battery during jump starting.
- Do not allow the terminals of one lead to touch those of the other lead.
- Do not touch the vehicles while jump starting.
- Apply handbrake. Manual transmission in neutral (Easytronic * in position N).

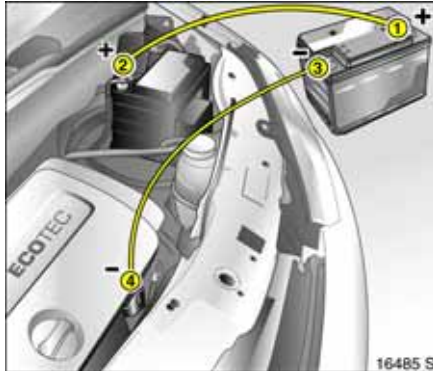

Connect the leads in the order shown in the illustration:

1. Connect one end of the first jump lead to the positive terminal **1** of the battery providing the jump start (identified by "+" sign on battery case or terminal).
2. Connect the other end of this lead to the positive terminal **2** of the discharged battery ("+" sign).
3. Connect the first end of the other jump lead to the negative terminal **3** of the battery providing the start ("-" sign).
4. Connect the other end of the second jump lead **4** to ground on the other vehicle, e.g. engine block or screw connection in the engine suspension.

- Do not connect leads to negative terminal of discharged battery!
- The connection point should be as far away from the discharged battery as possible.
- Route the leads so that they cannot catch on rotating parts in the engine compartment.
- Start the engine of the vehicle providing the jump start.
- After 5 minutes, start the other engine. Start attempts should be made at intervals of 1 minute and should not last longer than 15 seconds.
- After starting, allow both engines to idle for approx. 3 minutes with the leads connected.
- In order to avoid excess voltage in the electrical system, before removing a lead, switch on an electrical consumer (e.g. light, heated rear window) in the vehicle receiving the jump start.
- Reverse above sequence exactly when removing leads.



Towing the vehicle

To open the cap of the front right towing eye, disengage the bottom of the cap and pull downwards to remove.



The towing eye is located in the vehicle tool bag * in the luggage compartment beneath the spare wheel * - see illustration above - or, for model variants with a tyre repair kit *, in a stowage compartment beneath the floor cover - see page 177, Fig. 17918 S.

Spare wheel * – see page 177.

Tyre repair kit * – see page 182.

Jack and vehicle tools * – see page 176.



Screw in the towing eye anticlockwise as far as it will go until it stops in a horizontal position.

Attach a tow rope * – or better still a tow rod * – to the eye.

The towing eye must only be used for towing and not recovering a vehicle.

Switch on ignition to release steering column lock and to permit operation of brake lights, horn and windscreen wiper.

Manual transmission in neutral, Easytronic * in position N.

Drive slowly. Do not drive jerkily. Excessive tractive force can damage the vehicle.

⚠ Warning

For braking and steering, significantly higher forces are required: Brake assistance and steering assistance are effective only with the engine running.

To prevent the entry of exhaust fumes from the towing vehicle, switch on the air recirculation * and close the windows.

Contact a workshop who will provide a reliable, fast and professional repair.

If the automatic clutch is released manually after a power failure on vehicles with Easytronic ✱, towing is not permitted, see page 137. In this case, contact a workshop immediately.

After towing, unscrew towing eye by rotating clockwise and insert and close the cap.

Towing service

Entrust your vehicle only to the towing service of your choice and obtain an estimate on towing costs before employing any towing service. In this way you avoid unnecessary costs and possible insurance problems during claim processing.

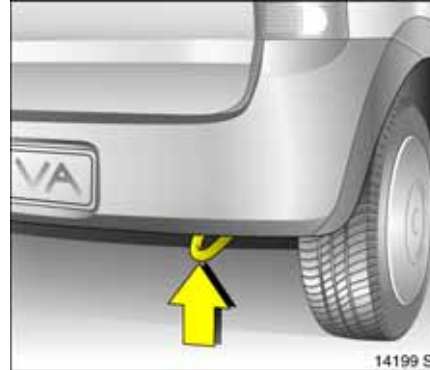

Towing another vehicle

Attach a tow rope ✱ – or better still a tow rod ✱ – to the rear towing eye on the right side of the vehicle underbody, but never to the rear axle.

Drive slowly. Do not drive jerkily. Excessive tractive force can damage the vehicle.

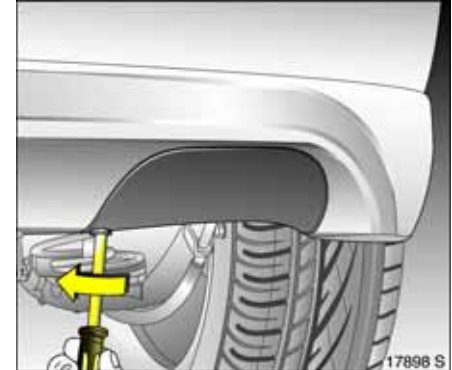

On some model variants, the towing eye is located behind a cover ✱.

Slacken the screw a quarter turn with a screwdriver ✱ (see illustration) and remove the cover.

The towing eye must only be used for towing and not recovering a vehicle.

Drive slowly. Do not drive jerkily. Excessive tractive force can damage the vehicle.

After towing, fit cover and secure with screw.



Warning triangle ▲*, first-aid kit ☺*

The warning triangle and first-aid kit (cushion) are strapped with a rubber band in the stowage compartment on the left-hand side of the luggage compartment, beneath the floor covering.

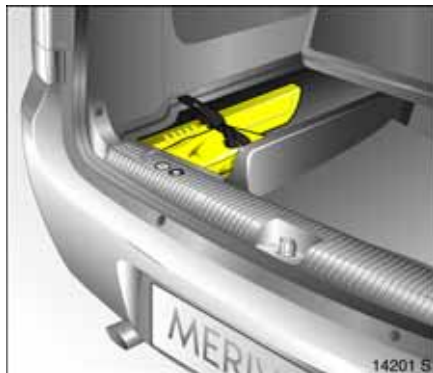

To open, remove the luggage compartment cover * – see page 54, lift the floor using the handle and raise towards the front.



Jack 🛠️ and vehicle tools *

The jack and the vehicle tools have been specially developed for your vehicle and must only be used on that vehicle. Only use jack for changing wheels.

The jack and vehicle tools are stowed in a bag underneath the spare wheel * in the luggage compartment.

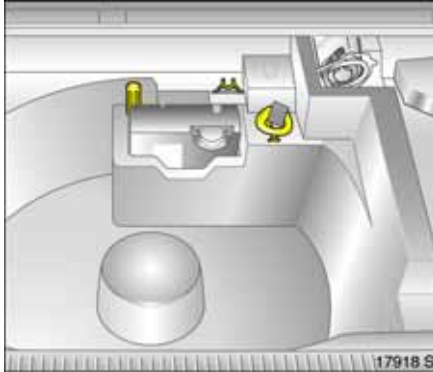

For vehicles with a tyre repair kit ✱, the tools are stowed together with the tyre repair kit in the stowage compartment beneath the floor cover in the luggage compartment.

Spare wheel ✱

Some vehicles are equipped with a tyre repair kit instead of a spare wheel. See page 182.



The spare wheel is in a recess in the floor of the vehicle and is screwed down with a wing nut.

To access the spare wheel, remove the luggage compartment cover ✱ – see page 54, lift the floor cover using the handle and raise towards the front. Fold the spare wheel cover up towards the front.

Stowing standard size tyres in the spare wheel well

The spare wheel well is not designed for all sizes of commercially available tyres. If a larger wheel must be stowed in the spare wheel well after changing wheels, place the floor cover on the overlaying wheel.

General information

Depending on the model variant, the spare wheel may be in the form of a temporary spare wheel ✱. Refer to the notes on this page and pages 162, 216.

On vehicles with alloy wheels ✱, the spare wheel may have a steel rim.

If you use winter tyres ✱, the spare wheel may still be fitted with a summer tyre. If you use the spare wheel, the vehicle's handling may be altered. Obtain a replacement for the faulty tyre as soon as possible, and have the wheel balanced and fitted to the vehicle.

The spare wheel may have a smaller tyre and a smaller rim than the wheels mounted on the vehicle¹⁾. Using the spare wheel may alter the driving behaviour of the vehicle. Have the defective tyre replaced as soon as possible, balance the wheel and have it mounted on the vehicle.

¹⁾ Country-specific version:
In some countries, the spare wheel may only be used as a temporary spare wheel.

Notes on temporary spare wheel *

- If the temporary spare wheel is used, the handling of the vehicle may change, particularly if winter tyres * are being used.
- The Electronic Stability Program ESP^{PLUS} * may switch itself off.
- Replace defective tyres as soon as possible, balance wheel and fit to vehicle.
- Fit only one temporary spare wheel.
- Do not drive faster than 50 mph (80 km/h).
- Take curves slowly.
- Do not use the temporary spare wheel for a lengthy period.
- Replace temporary spare wheel with full specification wheel without delay.
- Tyre chains * are not permitted on the temporary spare wheel. If tyre chains have to be used after a front wheel puncture, fit temporary spare wheel to the rear axle and fit a rear wheel to the front axle. Check tyre pressure and correct if necessary, see page 216.
- Note the information on the temporary spare wheel on pages 162, 216.

Notes on directional tyres *

Directional tyres only achieve their full performance potential when mounted in the prescribed direction of rotation. If, after a flat tyre, the tyre or spare wheel is mounted against the prescribed direction of rotation, observe the following:

- Driving conditions may be altered. Replace the defective tyre as soon as possible, balance the wheel and mount it on the vehicle.
- Do not drive faster than 50 mph (80 km/h).
- Drive especially carefully in wet or snowy weather.

For further information on directional tyres – see page 158.

Changing wheels

There may be a tyre repair kit instead of a spare wheel – see page 182.

To ensure your safety, make the following preparations and observe the following information when changing wheels:

- Park the vehicle on a level, firm and non-skid surface.
- Switch on the hazard warning lights, apply the handbrake, engage first gear or reverse gear (Easytronic * in position **N** or **R**).
- Correctly set up the warning triangle. Warning triangle – see page 176.
- Remove spare wheel from luggage compartment, see previous page.
- Before raising the vehicle, set the front wheels to the straight-ahead position.
- Never change more than one wheel at a time.

- Block the wheel diagonally opposite the wheel to be changed, by placing wedge blocks or equivalent in front and behind the wheel.
- Use the jack ✱ only to change wheels.
- If the ground on which the vehicle is standing is soft, a solid board (max. 1 cm thick) should be placed under the jack ✱. Using a thicker board could damage the jack and the vehicle.
- No people or animals may be in the vehicle when it is jacked up.
- Never crawl under a jacked-up vehicle.
- Do not start or run the engine while the vehicle is on the jack.
- Before inserting the wheel bolts when changing wheels, lightly grease the cone of each bolt. For this reason, carry some conventional grease.



1. Remove the wheel trim using the hook ✱ found with the vehicle tools. Vehicle tools - see page 176.

If the wheel trim has visible wheel bolts ✱, the trim can remain on the wheel. The retaining washers ✱ on the wheel bolts must not be removed.



Alloy wheels ✱:

Pry off the hub cap by inserting a screwdriver ✱ in the recess at the side of the hub cap. Protect the rim by placing a soft cloth between the screwdriver and the alloy wheel.

Remove wheel bolt caps ✱ from wheel bolts.





Alloy wheels with an anti-theft lock ✱:
Unscrew hub cap using key included in
vehicle tools ✱ and remove it.



2. Slacken wheel bolts using wheel bolt
wrench ✱, putting on the wheel bolt
wrench ✱ as far as possible.

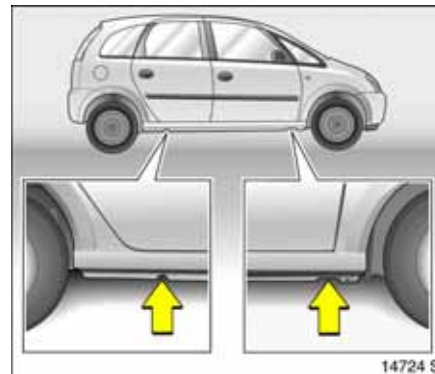

3. The jacking points on the vehicle
underbody are marked by depressions
on the lower body sill.

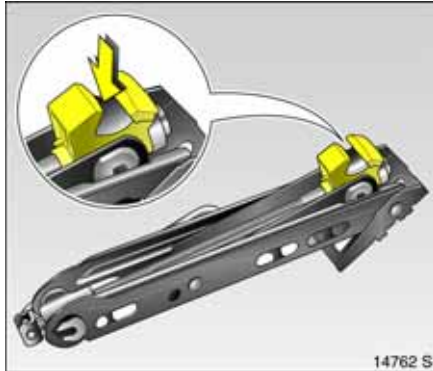

4. Before positioning the jack *, set it to the necessary height by rotating the eye by hand. Position the jack arm at the front or rear so that the jack claw (see arrow in illustration) spans the vertical base and grips in the recess in the vertical base. Make sure it is properly positioned.

With VXR * and VXR Line *, the jack * must not be used, since the vehicle may be damaged. Consult a workshop.

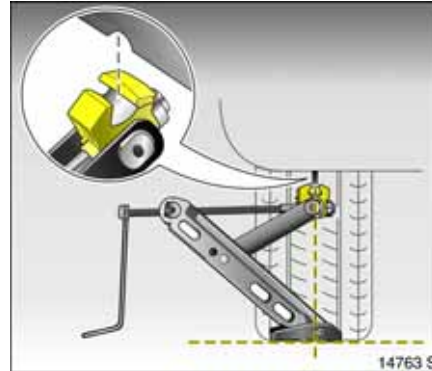

The edge of the jack base must be on the ground directly below the jacking point, in a manner that prevents it from slipping.

Raise vehicle by turning crank handle.

If this is not the case, carefully lower the vehicle immediately and reposition the jack.

5. Unscrew wheel bolts and wipe clean with a cloth. Then apply a light coating of grease to the wheel bolts. Do not grease the thread of the bolts. Do not put the wheel bolts down in a location where they may become soiled.



If the wheel bolts have retaining washers *, they must not be removed.

6. Change the wheel. Notes on spare wheel – see page 177, notes on temporary spare wheel – see page 178.
7. Screw in wheel bolts and tighten slightly, inserting the wheel bolt wrench * as far as possible.
8. Lower vehicle.
9. Tighten wheel bolts crosswise, putting on wheel bolt wrench * as far as possible.



10. Before refitting the wheel trim, clean the wheel around the retaining clips. The valve symbol ✱ on the back of the wheel trim must point towards valve on wheel.

Align and refit wheel trim or wheel bolt caps ✱.

Alloy wheels ✱:

Put hub cap on and engage, inserting pin on rear of hub cap into relevant hole in wheel.

Alloy wheels with anti-theft lock ✱:

Put hub cap on. Insert and tighten anti-theft lock ✱.

11. Stow the replaced wheel, vehicle tools and warning triangle - see pages 176, 177.
12. Check the tyre inflation pressure of the newly fitted wheel. Adjust as necessary.
13. Have the tightening torque of the wheel bolts on the new wheel checked on the vehicle using a torque wrench as soon as possible and, if necessary, corrected. Tightening torque – see page 216.
14. Replace the faulty tyre on the wheel that was removed.
15. Replace temporary spare wheel ✱ with a full specification wheel without delay.

Tyre repair kit ✱

Minor damage to the tyre tread and sidewall, e.g. foreign bodies, can be remedied with the tyre repair kit.

Do not remove the foreign body from the tyre.

Tyre damage exceeding 4 mm or that is on the rim cannot be repaired with the tyre repair kit.

Warning

Driving with tyre pressures that are too low or deflated tyres can cause invisible damage to the tyre. This damage cannot be eliminated with a tyre repair kit. Park the vehicle and contact a workshop.

Important information – see page 185.

In the event of a flat tyre:

- Switch on hazard warning lights and apply handbrake. In vehicles with manual transmission, select 1st gear or reverse gear (Easytronic ✱ in position **N** or **R**).
- Correctly set up the warning triangle. Warning triangle – see page 176.

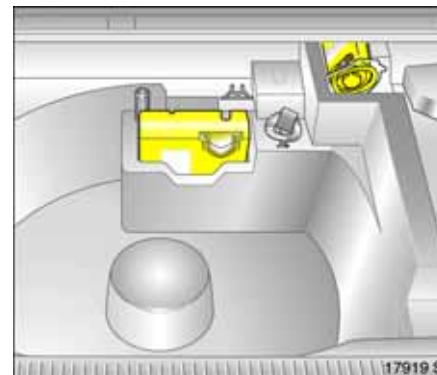

The tyre repair kit is in a stowage compartment beneath the floor cover in the luggage compartment.

1. Remove bag containing tyre repair kit from stowage compartment. Carefully remove parts from bag.
2. Remove the compressor.

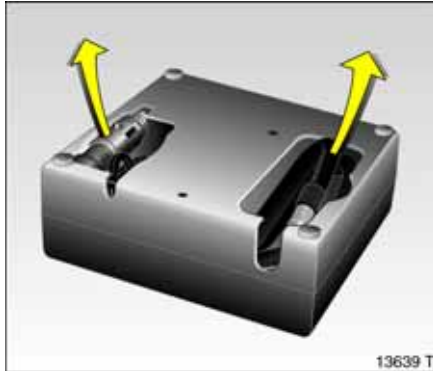

3. Remove the electrical connection cable and air hose from the stowage compartments on the underside of the compressor.



4. Screw the air compressor hose to the connection on the sealant bottle.
5. Fit the sealant bottle in the retainer on the compressor.
- Set the compressor near the tyre in such a way that the sealant bottle is upright.
6. Remove the valve cap from the defective tyre.

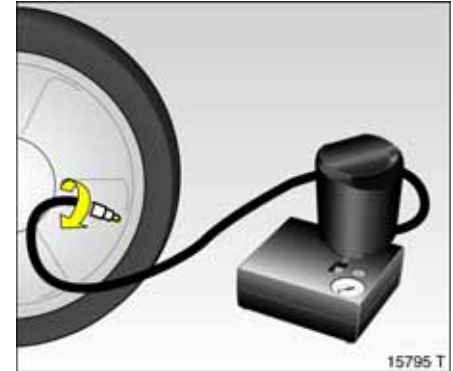

7. Screw the filler hose to the tyre valve.
8. The switch on the compressor must be set to **O**.
9. Plug the compressor connector into the accessory socket or the cigarette lighter socket. For accessory sockets, see page 79.

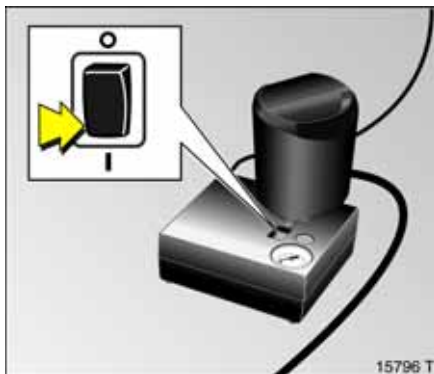

10. Switch on ignition.
11. Set the rocker switch on the compressor to I. The tyre is filled with sealant.
12. While the sealant bottle drains (approx. 30 seconds) the pressure indicator on the compressor briefly points to 6 bar (87 psi). Pressure then sinks again.
13. All of the sealant is pumped into the tyre. Afterwards, the tyre is filled with air.
14. The prescribed tyre pressure – see page 216, should be reached within 10 minutes. Switch off the compressor when the correct pressure is obtained.

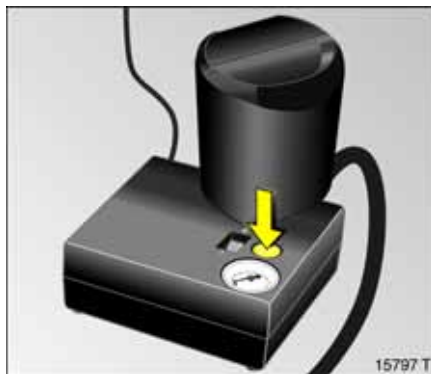

If the specified tyre pressure is not reached within 10 minutes, remove the tyre repair kit. Move the vehicle through one tyre rotation, approx. 2 metres, in either direction. Reconnect the tyre repair kit and continue the filling process for 10 minutes. If the specified tyre pressure is still not reached, the tyre is too badly damaged. Park the vehicle and contact a workshop.

Drain excess tyre pressure with the button over the pressure indicator.

Do not run the compressor for more than 10 minutes, see "Important information" on page 185.

15. Detach the tyre repair kit. Screw the filler hose to the free connection on the sealant bottle. This prevents sealant leakage. Stow the tyre repair kit in the luggage compartment.
16. Wipe away any sealant spill with a cloth.
17. Dismantle the warning triangle and stow it in the luggage compartment – see page 176.
18. The provided sticker shows the maximum permitted speed at which the vehicle may be driven after a tyre repair has been made. Affix sticker in driver's field of view.
19. Continue driving immediately to allow the sealant to distribute evenly throughout the tyre. Stop after approx. 6 miles (10 km) or no more than 10 minutes, and check tyre pressure. Screw the air compressor hose directly onto the tyre valve (see Fig. 15798 T on next page).

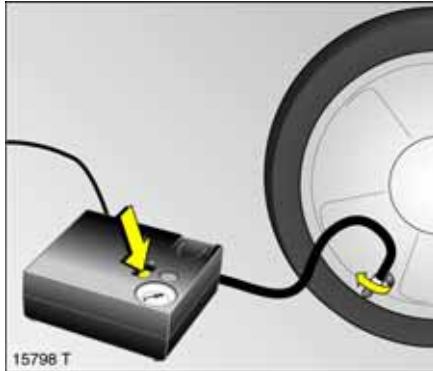

As long as the tyre pressure is more than 1.3 bar (19 psi) it may be adjusted to the prescribed value. Repeat the procedure until there is no more pressure loss.

If the tyre pressure has fallen below 1.3 bar (19 psi), the vehicle may no longer be used. Contact a workshop.

20. Stow the tyre repair kit in the luggage compartment – see page 182.

Important

Warning

Do not drive faster than 50 mph (80 km/h).

Do not use the temporary spare wheel for a lengthy period.

Steerability and driving behaviour may be impaired.

Have the repaired tyre replaced as soon as possible.

The driving comfort of the repaired tyre is severely affected, therefore have this tyre replaced.

If the compressor makes abnormal noises or heats up greatly, switch it off for at least 30 minutes.

The integrated safety valve opens at a pressure of 7 bar (102 psi).

Protect the compressor from moisture and rain.

The sealant can only be stored for approx. 4 years. After this time, the sealing properties can no longer be guaranteed. Heed the expiration date on the sealant bottle.

The sealant bottle can only be used once. Replace a used sealant bottle.

The compressor and sealant can be used from approx. -30 °C.

Dispose of a used tyre repair kit in accordance with applicable legislation.

An adapter for filling air mattresses, inner tubes, etc. is located on the underside of the compressor. Remove by unscrewing the air compressor hose and pulling out the adapter.

Electrical system

Warning

Electronic ignition systems generate very high voltages. Do not touch the ignition system; high voltage can be fatal.

Fuses

In the vehicle, there are two fuseboxes: one in the vehicle interior, below the instrument panel, and another in the engine bay, in front of the windscreen.

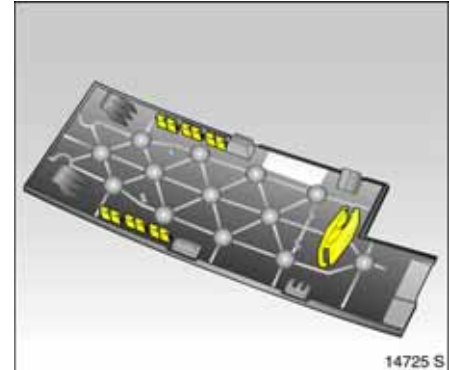

We recommend carrying a complete set of fuses.

Put spare fuses in the provided location in the fusebox in the instrument panel (marked in yellow in the illustration). Open cover – see page 188.

Before replacing a fuse, turn off the respective switch and the ignition.

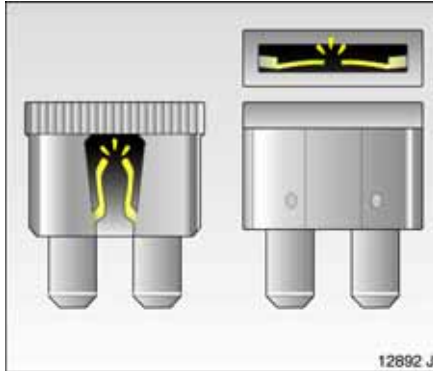

A defective fuse can be recognized by its melted wire. A new fuse should only be installed after the cause of the trouble has been rectified.

To help in replacing fuses, there is a special fuse-gripping tool in the fusebox ✱.

Slot fuse-gripping tool onto fuse and withdraw it.

Always use fuses with the specified rating. This is shown on each fuse, and is also indicated by the fuse colour and the plug-in location in the fusebox.

Fuse colour	Fuse rating
Grey	2 A
Brownish yellow	5 A
Brown	7.5 A
Red	10 A
Blue	15 A
Yellow	20 A
Light green	30 A
Pink (Maxi-Fuse)	30 A
Orange	40 A
Red (Maxi-Fuse)	50 A
Yellow (Maxi-Fuse)	60 A
Black (Maxi-Fuse)	80 A

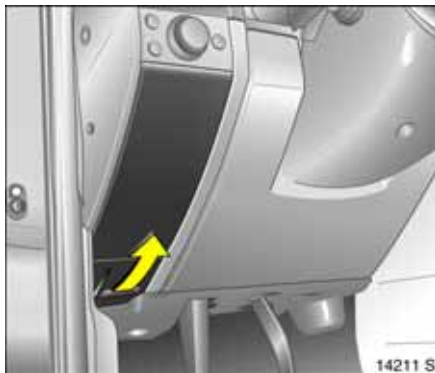

Fuses and the most important circuits they protect

Fusebox in passenger compartment

Disengage fusebox cover at bottom and remove.

Some circuits may be protected by several fuses.

No.	Circuit	Rating
1	Central control unit	7.5 A
2	Im mobiliser, hazard warning lights, exterior lighting	5 A
3	Headlight wash system	30 A

No.	Circuit	Rating	No.	Circuit	Rating
4	Infotainment system, diesel engine	20 A	17	–	–
5	–	–	18	Adaptive Forward Lighting (AFL)	15 A
6	–	–	19	Central locking system	20 A
7	Starter, diesel engine: engine controller	10 A	20	Interior lighting, reading light	5 A
8	Horn	15 A	21	Windscreen wash system	15 A
9	Fuel injection system, fuel pump, stationary heater	20 A	22	Rear electric windows	20 A
10	Tum signal lights	20 A	23	Slide / tilt sunroof, skylight roof	20 A
11	Infotainment system, Information display	20 A	24	Vauxhall alarm system	5 A
12	Heated rear window, exterior mirrors	7.5 A	25	Rear window wiper	15 A
13	Central locking, Vauxhall alarm system	10 A	26	Ignition system, engine electronics	15 A
14	Engine control Petrol engine: 15 A Diesel engine: 7.5 A		27	Engine control, airbags, ESP ^{Plus}	5 A
15	Engine control unit, Z 17 DTH engine	10 A 15 A	28	Air conditioning system	7.5 A
16	Accessory socket, cigarette lighter	20 A	29	Front left electric window	20 A
			30	–	–
			31	Engine control, Z 17 DTH engine	7.5 A 10 A
			32	Front right electric window	20 A

No.	Circuit	Rating
33	Central control module, immobiliser, control indicators	5 A
34	Windscreen wiper	30 A
35	Interior lighting, interior mirror, information display	5 A
36	Brake light, ABS, ESP® ^{Plus}	15 A
37	Cigarette lighter, auxiliary heater	20 A
38	Seat heater (left)	15 A
39	Seat heater (right)	15 A
40	Adaptive Forward Lighting (AFL), automatic headlight range adjustment	5 A
41	Reversing lights	15 A

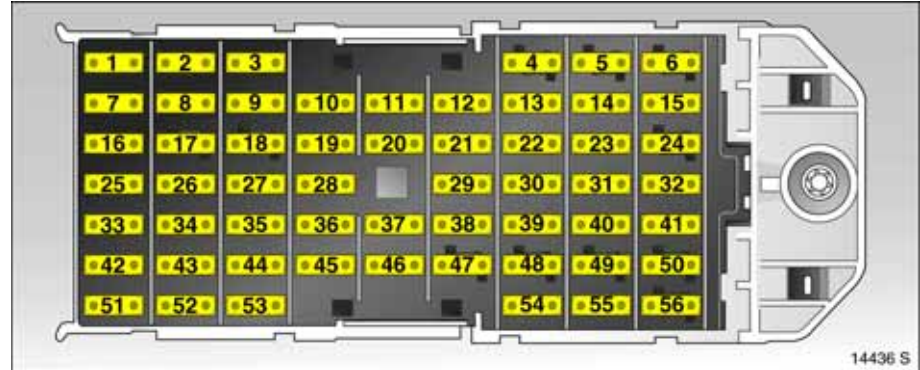

No.	Circuit	Rating
42	Engine cooling, lighting	5 A
43	Left parking light	5 A
44	Right parking light	5 A
45	Fog tail light	10 A
46	Front fog lights	15 A
47	Towing equipment, accessory socket	20 A
48	Diesel filter heater	30 A
49	–	–
50	Diesel filter heater	30 A

No.	Circuit	Rating
51	Left dipped beam: Xenon headlight	15 A
	Halogen headlight	10 A
52	Right dipped beam: Xenon headlight	15 A
	Halogen headlight	10 A
53	Sunroof, electric windows, radio	5 A
54	Main beam (left)	10 A
55	Main beam (right)	10 A
56	–	–

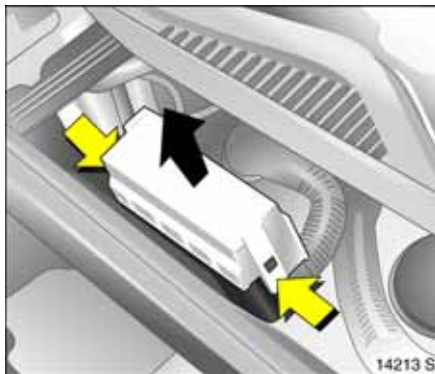

Fusebox in engine compartment

The fusebox is at the front of the engine compartment, near the windscreen.

Warning

Turn off engine before opening fusebox, risk of injury.

Disengage cover of fusebox from lug and lift off.

Some circuits may be protected by several fuses.

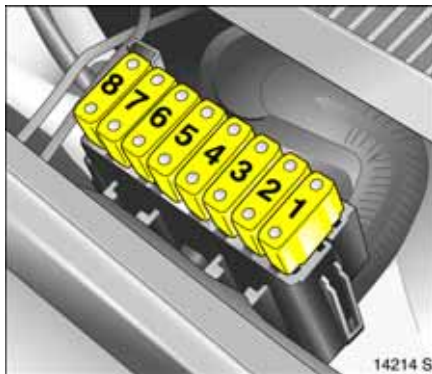

The following fuses are Maxi fuses.

No.	Circuit	Rating
1	Interior fan	30 A
2	Electric Power Steering (EPS)	50 A
3	ABS	40 A
4	Easytronic, diesel preheating system	80 A
5	Heated rear window	30 A
6	Engine cooling	50 A
7	Starter	30 A
8	Engine cooling	40 A

Bulb replacement

Before replacing a bulb, switch ignition off and switch relevant switch off.

Only hold new bulb at base! Do not touch the bulb glass with bare hands, otherwise fingerprints on the glass evaporate. Residue builds up on the reflector eventually resulting in a dull reflector. Inadvertently stained bulbs may be cleaned with a clean non-fluffy cloth, using alcohol or white spirits.

The replacement bulb must be in accordance with the data on the base of the defective bulb. Do not exceed wattage given on bulb base.

Headlight aiming

We recommend that headlight adjustment be carried out by a workshop who will have special equipment.

When adjusting headlights, headlight range adjustment must be set to 0.

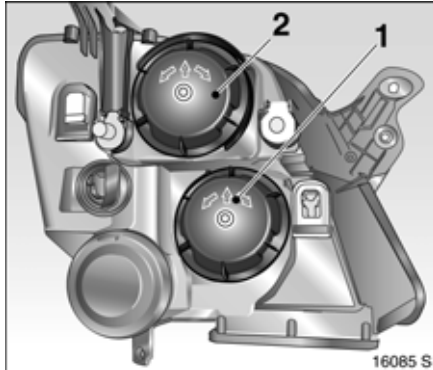

Halogen headlight system

Headlights with separate systems for dipped beam 1 (bottom lights) and main beam 2 (top lights).

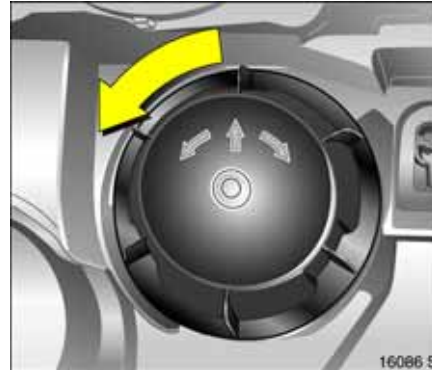

Dipped beam

1. Open bonnet and engage support.
2. To replace the bulb on the left-hand side, remove the relay box.

To replace the bulb on the right-hand side, remove the air hose from the air filter.

3. Rotate the headlight protective cover anticlockwise and remove.

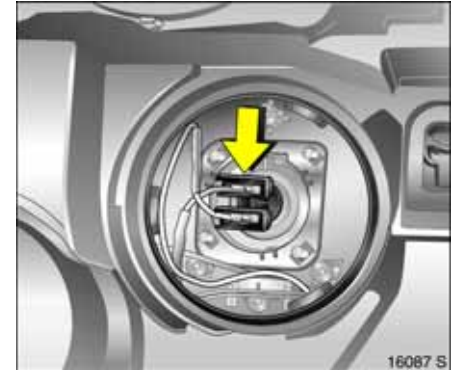

4. Press the bulb down in the holder.
5. Remove bulb with connector from reflector housing.

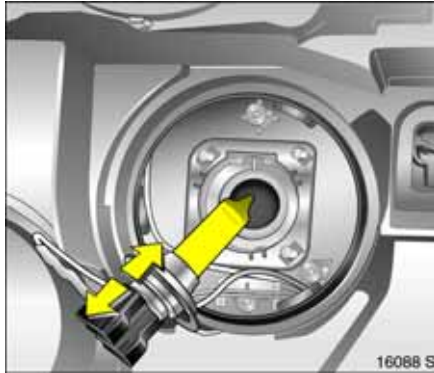

6. Detach plug connector from bulb base.
7. Fit connector onto new bulb, without touching the glass.
8. Insert the bulb with connector so that the lug engages in the recess in the reflector.
9. Place headlight protective cover in position and close.
10. Insert relay box after replacing bulb at left-hand side.

After replacing the bulb on the right-hand side, reattach the air hose to the air filter and engage.

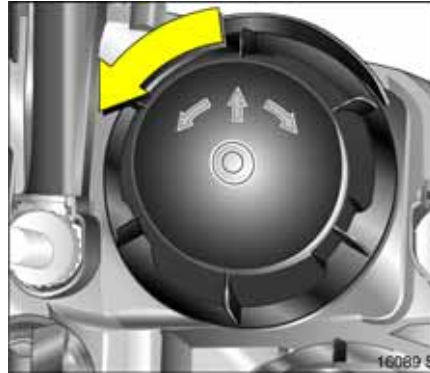

Main beam

1. Open bonnet and engage support.
2. To replace the bulb on the left-hand side, remove the relay box.
To replace the bulb on the right-hand side, remove the air hose from the air filter.
3. Rotate the headlight protective cover anticlockwise and remove.

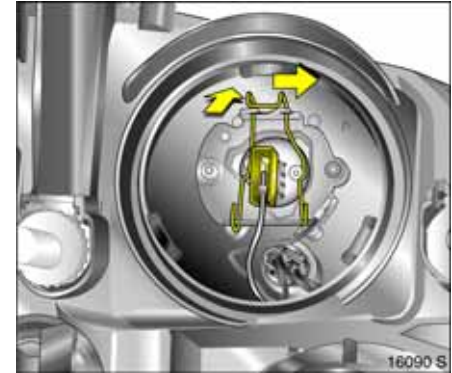

4. Detach plug connector from bulb.
5. Disengage spring wire clip from retaining lugs by moving it forwards and swivel it aside.

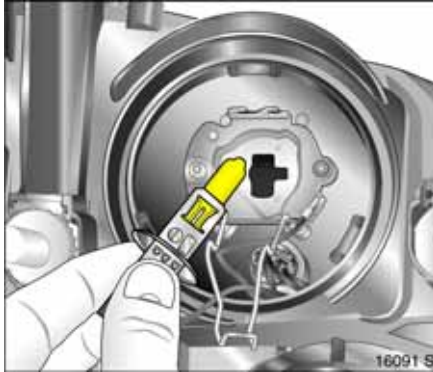

6. Remove bulb from reflector housing.
7. When fitting a new bulb, engage the lugs in the recesses on the reflector without touching the glass.
8. Engage spring wire clip, plug connector onto bulb.
9. Place headlight protective cover in position and close.
10. Insert relay box after replacing bulb at left-hand side.

After replacing the bulb on the right-hand side, reattach the air hose to the air filter and engage.

Halogen headlight system *, Adaptive Forward Lighting (AFL) *

Halogen headlight system for dipped and main beam in combination with curve and turn lighting.

Warning

We recommend having bulbs for dipped beam, main beam, turn lighting, parking lights and turn signal lights replaced by a workshop only.

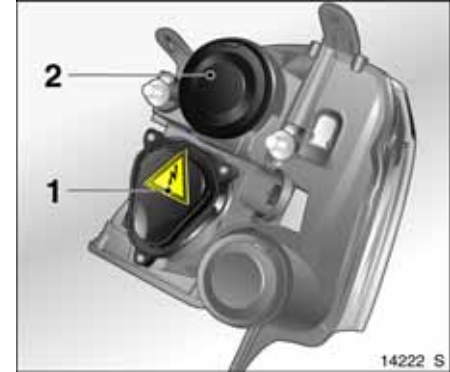

Xenon headlight system

Headlights with separate systems for dipped beam 1 (bottom lights) and main beam 2 (top lights).

Dipped beam

Warning

The dipped beam works with very high electrical voltage. Do not touch, risk of fatal injury. Have bulbs changed by a workshop.

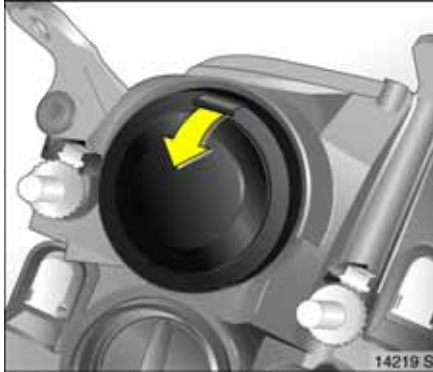

Main beam

1. Open bonnet and engage support.
2. Remove headlight protective cover.

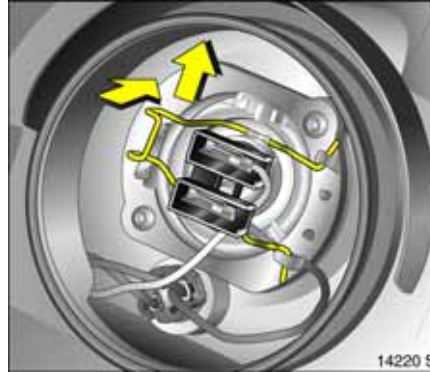

3. Detach plug connector from bulb.
4. Disengage spring wire clip from retaining lug and swivel upward.



5. Remove bulb from reflector housing.
6. When fitting a new bulb, engage the lugs in the recesses on the reflector without touching the glass.
7. Engage spring wire clip, plug connector onto bulb.
8. Place headlight protective cover in position and close.

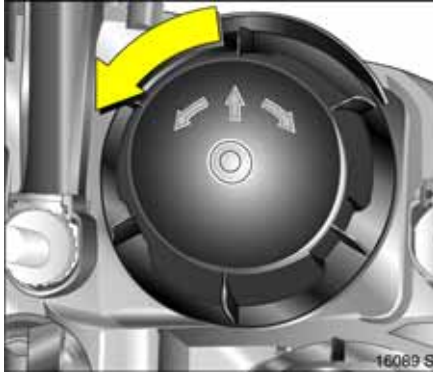

Parking lights

1. Open bonnet and engage support.
2. To replace the bulb on the left-hand side, remove the relay box.

To replace the bulb on the right-hand side, remove the air hose from the air filter.

3. Turn the main beam headlight cover cap anticlockwise and remove.

For vehicles with Xenon headlight system *, remove the headlight cover cap – see page 194, Fig. 14219 S.



4. Push side lugs of parking light holder together and remove holder from reflector.



5. Remove bulb from socket.
6. Insert new bulb, without touching the glass.
7. Insert bulb socket in reflector.
8. Place headlight protective cover in position and close.
9. Insert relay box after replacing bulb on left-hand side.
10. After replacing the bulb on the right-hand side, reattach the air hose to the air filter and engage.

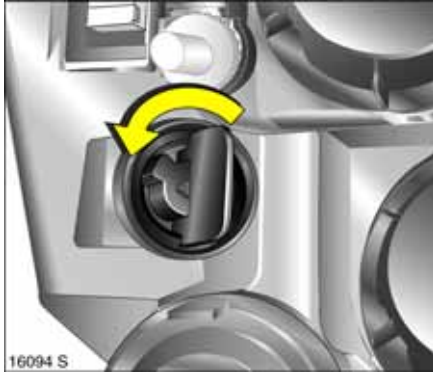

Front turn signal lights

1. Open bonnet and engage support.
2. To replace the bulb on the left-hand side, remove the relay box.
To replace the bulb on the right-hand side, remove the air hose from the air filter.
3. Rotate left turn signal light bulb carrier and disengage.



4. Remove bulb mounting from reflector.
5. Detach bulb from bulb mounting.
6. Insert new bulb into bulb mounting, without touching the glass.
7. Insert new bulb so that the two lugs on the bulb mounting engage in the recesses in the reflector.

8. Rotate bulb carrier to right as far as it will go.
9. Insert relay box after replacing bulb at left-hand side.
After replacing the bulb on the right-hand side, reattach the air hose to the air filter and engage.

Side turn signal lights

Have bulbs changed by a workshop.

Front fog lights *

Have bulbs changed by a workshop.

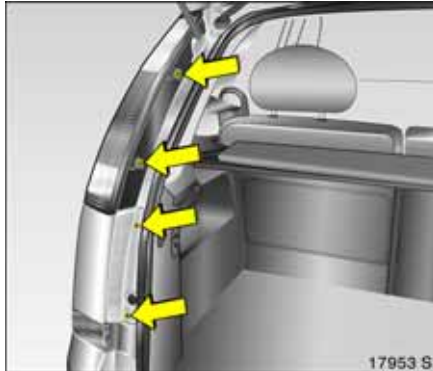

Tail lights

1. Unscrew the four screws from the bulb housing using a screwdriver ✱.
2. Pull bulb housing, reflector and fog tail light out of retainers to rear.

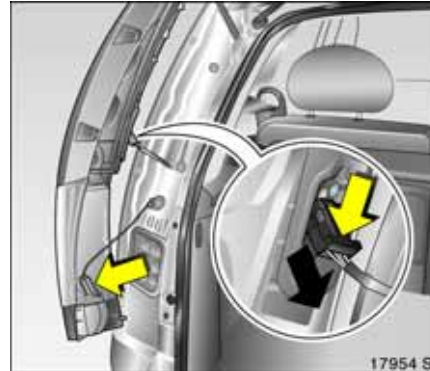

3. Disengage the plug of the main bulb mounting by pressing (arrow in illustration) and pull from bulb mounting.
4. Disengage lug of fog tail light plug (see arrow in illustration) and remove.

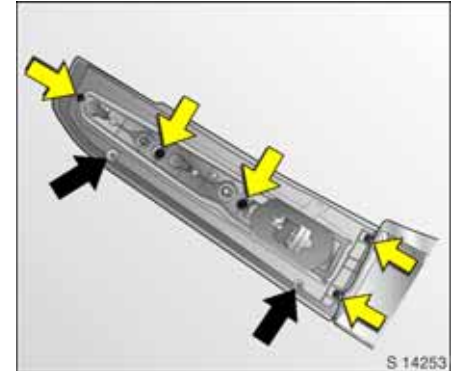

5. Slacken both screws on the back of the main bulb mounting. Press the catches of the bulb mounting together and remove the bulb mounting.



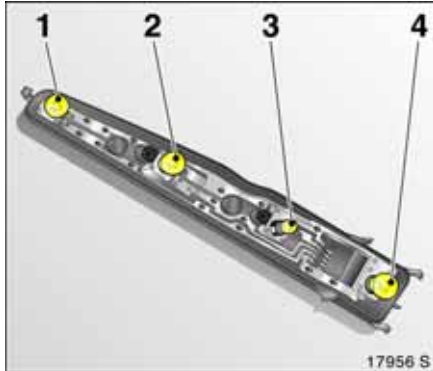

Bulbs in main bulb mounting:

- 1 = Turn signal
- 2 = Brake light
- 3 = Tail light
- 4 = Reversing light

Remove bulb from socket.

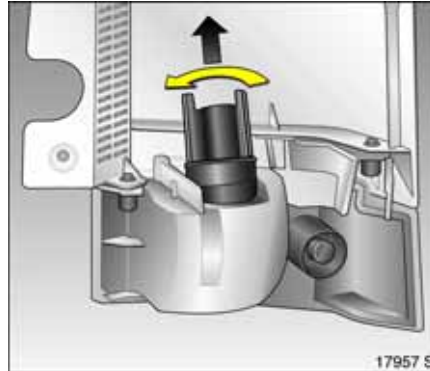

Fog tail light bulb:

Rotate bulb mounting anticlockwise and disengage.

Remove bulb from socket.

6. Insert new bulb, being careful not to touch the bulb glass, and engage the bulb mounting in the bulb housing.
7. Retighten both screws on the back of the main bulb mounting. Connect both plugs. Insert bulb housing with retaining pins to vehicle body and fasten housing with the four screws.



Number plate light

1. Insert screwdriver vertically on right-hand side of bulb housing, exert pressure towards the right and disengage spring. Remove the bulb housing downwards.

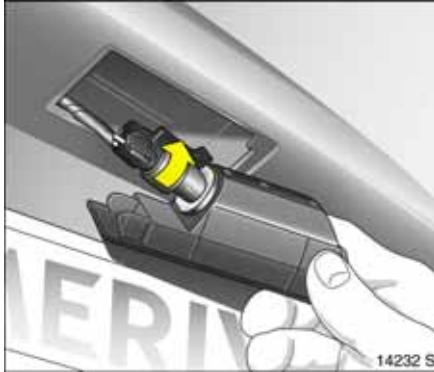

2. Rotate bulb holder to left and disengage.



3. Remove bulb from socket.
4. Insert new bulb, without touching the glass.

5. Engage bulb holder by rotating right in bulb housing. Insert bulb housing and engage.



Courtesy lights

Front courtesy light, reading lights *

To ensure that no power is supplied to the lights, close the doors before removing.

1. Unclip the scatter disc on the housing at the point shown in the illustration.



2. Remove bulb from socket.
3. Insert new bulb, without touching the glass.
4. Mount housing and engage in position.

Rear courtesy light,
rear reading lights *
Have bulbs changed by a workshop.

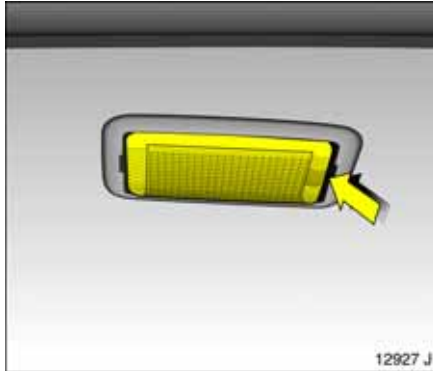

Glove compartment light, luggage compartment light

To ensure that no power is supplied to the lights, close the doors or hold the contact switch depressed before removing.

1. Prise the light out with a screwdriver * and remove.

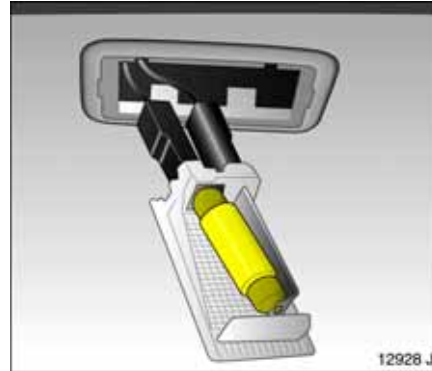

2. Press bulb slightly towards spring clip and remove.
3. Insert new bulb, without touching the glass.
4. Insert light in opening and engage in position.

**Instrument illumination,
Information display illumination**
Have bulbs changed by a workshop.

Vehicle care

When caring for your vehicle, observe all national environmental regulations, particularly when washing it.

Regular, thorough care helps to improve the appearance of your vehicle and maintain its value over the years. It is also a prerequisite for warranty claims for any paint or corrosion damage.

The following pages contain tips for vehicle care which, if used properly, will help combat the unavoidable damaging effects of the environment.

Vehicle care aids *

Vehicle wash:

- Wash brush,
- Car Shampoo,
- Car Sponges,
- Insect Removal Sponge,
- Chamois Leather,
- Wheel cleaners,
- Engine cleaners,
- Glass cleaners.

Vehicle care:

- Paintwork Cleaner,
- Paintwork Polish,
- Metallic Paintwork Wax,
- Hard wax,
- Touch-up pens,
- Touch-Up / Aerosol Paint,
- Wheel Preserver,
- Insect Remover,
- Window Cleaning Spray,
- Vauxhall Windscreen Wash Solvent,
- Silicone Oil for Rubber Seals,
- Cleaner,
- Alloy Wheel Cleaner,
- Alloy Wheel Preserver,
- Rust Preventative.

Washing

The paintwork of your vehicle is exposed to environmental influences, e.g. continuous changes in weather conditions, industrial waste gases and dust or thawing salts, so wash and wax your vehicle regularly. When using automatic car washes, select a programme which includes waxing.

Bird droppings, dead insects, resin, pollen and the like should be cleaned off immediately, as they contain aggressive constituents which can cause paint damage.

If using a car wash, comply with the pertinent instructions of the manufacturer of the car wash. Windscreen wiper and rear window wiper must be switched off, see pages 11 and 12. Unscrew antenna * and roof-mounted luggage carrier *, stand on door sill to reach them more easily.

If you wash your vehicle by hand, make sure that the insides of the wings are also thoroughly rinsed out.

Clean edges and folds on opened doors and flaps as well as the areas they cover.

Thoroughly rinse off and leather-off the vehicle. Rinse leather frequently. Use separate leathers for paint and window surfaces: remnants of wax on the windows will impair vision.

Observe national regulations.

Waxing

Wax your vehicle regularly, in particular after it has been washed using shampoo, and at the latest when water no longer forms beads on the paintwork, otherwise the paintwork will dry out.

Also wax edges and folds on opened doors and flaps as well as the areas they cover.

Polishing

Polishing is necessary only if the paint has become dull or if solid deposits have become attached to it.

Paintwork polish with silicone forms a protective film, making waxing unnecessary.

Plastic body parts should not be treated with wax and polish.

Use Metallic Paintwork Wax on vehicles with a metallic-effect paint finish.

Wheels

Use a pH-neutral wheel cleaning agent to clean the wheels.

Wheels are painted and can be treated with the same agents as the body. For alloy wheels, we recommend use of Alloy Wheel Preserver.

Paintwork damage

Repair minor paintwork damage such as stone chips, scratches etc. immediately using a touch-up pen or spray, before rust forms. If rust has already formed, have a workshop eliminate the cause. Also check the surfaces and edges facing the road surface on which rust may have developed unnoticed for some time.

Exterior lights

Headlight and other protective light bezels are made of plastic. If they require additional cleaning after the vehicle has been washed, clean them with Car Shampoo. Do not use any abrasive or caustic agents, do not use an ice scraper, and do not clean them dry.

Plastic and rubber parts

If the car wash does not clean plastic and rubber parts adequately, use cleaner suitable for vehicle interiors. Do not use any other agent, and in particular do not use solvents or petrol.

Wheels and tyres

Do not use high-pressure jet cleaners on wheels and tyres.

Interior and upholstery

Clean the vehicle interior, including the instrument panel fascia, using interior cleaner.

The instrument panel should only be cleaned using a soft damp cloth.

Clean fabric upholstery with a vacuum cleaner and brush. To remove stains, use cleaner that is suitable for both fabrics and vinyl.

Do not use cleaning agents such as acetone, tetrachloride, paint thinner, paint remover, nail varnish remover, washing powder or bleach. Petrol is also unsuitable.

Open Velcro fasteners on clothing could damage seat upholstery. Make sure that Velcro fasteners are closed.

Seat belts

Always keep seat belts clean and dry.

Clean only with lukewarm water or Cleaner.

Windows

When cleaning the heated rear window, make sure that the heating element on the inside of the window is not damaged.

Use a soft lint-free cloth or chamois leather in conjunction with Window Cleaning Spray and Insect Remover.

Vauxhall Windscreen Wash Solvent is suitable for defrosting windows.

For mechanical removal of ice, use a commercially available sharp-edged ice scraper. Press the scraper firmly against the glass so that no dirt can get under it and scratch the glass.

Windscreen wiper blades

Wax, such as that used in car washes, can cause streaking on the windscreen when the wiper is used.

Smearing wiper blades can be cleaned with a soft cloth and Vauxhall Windscreen Wash Solvent, and replaced if necessary – see page 233.

Locks

The locks are factory-lubricated with a high quality lock cylinder grease. This prevents the locks from freezing. Only use de-icer in urgent cases as this destroys the grease and damages the function of the locks. After using de-icer, have a workshop regrease the locks.

Engine compartment

Look after areas in the engine compartment that are painted in the same colour as the vehicle like any other paintwork.

It is advisable to wash the engine compartment before and after winter and preserve it with wax. Before engine washing, cover alternator and brake fluid reservoir with plastic sheeting.

When washing the engine with a steam-jet cleaner, do not direct the steam jet at components of the Anti-lock Brake System (ABS), the automatic air conditioning system ❄ or the belt drive and its components.

Engine washing also removes subsequently applied protective wax. Therefore after washing, have a workshop protect the engine, parts of the braking system in the engine bay, axle elements with steering, body elements and cavities, thoroughly with protective wax.

An engine wash can be performed in the spring in order to remove dirt that has adhered to the engine compartment, which may also have a high salt content. Check protective wax layer and make good if necessary.

Do not use high-pressure jet cleaners in the engine compartment.

Underbody

Your vehicle has a factory-applied PVC undercoating in the wheel arches (including the longitudinal members) which provides permanent protection and needs no special maintenance. The surfaces of the vehicle underbody not covered by PVC are provided with a durable protective wax coating in critical areas.

On vehicles which are washed frequently in automatic car washes with underbody washing facility, the protective wax coating may be impaired by dirt-dissolving additives, so check the underbody after washing and have it waxed if necessary.

Before the start of the cold weather season, check the PVC coating and protective wax coating and, if necessary, have them restored to perfect condition.

Caution - commercially available bitumen / rubber materials can damage the PVC coating. We recommend that you have underbody work carried out by a workshop, who knows the prescribed materials and has experience in the use thereof.

The underbody should be washed following the end of the cold weather season to remove any dirt adhering to the underbody since this may also contain salt. Check protective wax coating and, if necessary, have it restored to perfect condition.

Technical Data

Vehicle documents, identification plate.....	206
Vehicle identification data.....	207
Coolant, brake fluid, oils.....	207
Engine data.....	208
Performance.....	210
Fuel consumption, CO ₂ emissions.....	212
Weights, payload and roof load.....	214
Tyres.....	216
Electrical system.....	218
Capacities.....	219
Dimensions.....	221
Mounting dimensions of towing equipment *.....	222

Vehicle documents, identification plate

The technical data is determined in accordance with European Community standards. We reserve the right to make modifications. Specifications in the vehicle documents always have priority over those given in this manual.

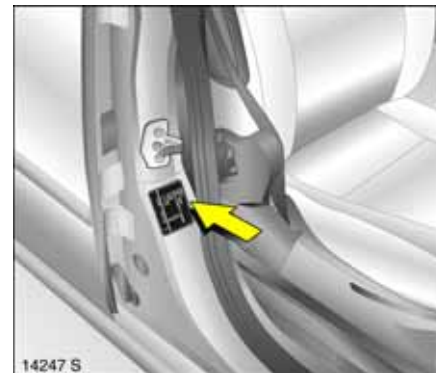

The identification plate is affixed to the front right door frame.



Information on identification plate:

- 1 Manufacturer
- 2 Type approval number
- 3 Vehicle Identification Number
- 4 Gross Vehicle Weight rating
- 5 Permissible Gross Train Weight
- 6 Maximum permissible front axle load
- 7 Maximum permissible rear axle load
- 8 Vehicle-specific or country-specific data

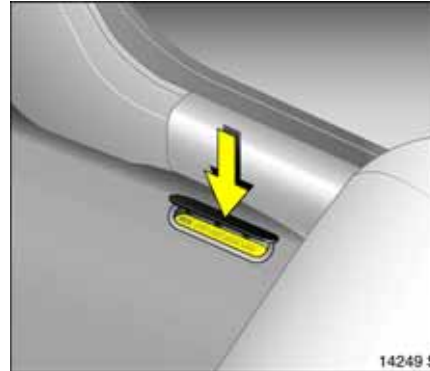

Vehicle identification data

The Vehicle Identification Number is stamped on the identification plate (see previous page) and in the vehicle floor on the right-hand side under a cover between the driver's door and seat.

In other model variants, the identification plate may also be affixed to the instrument panel.

Engine identifier and engine number: marked on left-hand side of engine in engine block.

Coolant, brake fluid, oils

Only use approved fluids.

Use of unsuitable fluids can cause serious damage to the vehicle.

Engine oils

Information on engine oils is found in the Service Booklet.

Engine data

Sales designation Engine identifier code	1.4 TWINPORT Z 14 XEP	1.6 TWINPORT Z 16 XEP	1.8 Z 18 XE	VXR Z 16 LET
Number of cylinders	4	4	4	4
Piston displacement (cm ³)	1364	1598	1796	1598
Brake horse power (bhp) at rpm	66 5600	77 6000	92 6000	132 5500
Torque (Nm) at rpm	125 4000	150 3900	165 4600	230 2200-5400
Type of fuel ¹⁾	Petrol	Petrol	Petrol	Petrol
Octane requirement (RON) ²⁾ unleaded or unleaded or unleaded	95 ³⁾ 98 ³⁾ 91 ³⁾⁴⁾	95 ³⁾ 98 ³⁾ 91 ³⁾⁴⁾	95 ³⁾ 98 ³⁾ 91 ³⁾⁴⁾	95 ³⁾⁵⁾ 98 ³⁾ _6)
Max. permissible engine speed, continuous operation (rpm) approx.	6200	6500	6500	6500
Oil consumption (l/1000 km)	0.6	0.6	0.6	0.6

1) Standard quality fuels, e.g. unleaded DIN EN 228.

2) Bold type: recommended fuel.

3) Knock control system automatically adjusts ignition timing according to type of fuel used (octane number).

4) Slight reduction in engine output and torque if 91 RON is used.

5) Slight reduction in engine output and torque if 95 RON is used.

6) Do not use fuel of octane number 91 RON.

Engine data

Sales designation Engine code	1.3 CDTI Z 13 DTJ	1.7 CDTI Z 17 DTH
Number of cylinders	4	4
Piston displacement (cm ³)	1248	1686
Brake horse power (bhp) at rpm	55 4000	74 4400
Torque (Nm) at rpm	170 1750 to 2500	240 2300
Type of fuel ¹⁾	Diesel	Diesel
Cetane requirement (CN) ²⁾	49 (D)³⁾	49 (D)³⁾
Max. permissible engine speed, continuous operation (rpm) approx.	5100 to 5300	4700
Oil consumption (l/1000 km)	0.6	0.6

¹⁾ Standard quality fuels, e.g. diesel DIN EN 590.

²⁾ Standard quality fuels: D = diesel, bold type: recommended fuel

³⁾ A lower value is possible with winter diesel fuels.

210 Technical Data

Performance

(approx. mph / km/h¹⁾)

Engine ²⁾	Z 14 XEP	Z 16 XEP	Z 18 XE	Z 16 LET
Top speed				
5-speed manual transmission	104 / 168	112 / 181	118 / 190	–
5-speed sports transmission	–	–	119 / 192	–
6-speed manual transmission	–	–	–	138 / 222
Easytronic	–	112 / 181	118 / 190	–

¹⁾ The maximum speed is achievable with a maximum of half payload. Optional equipment may reduce the specified maximum speed of the vehicle.

²⁾ Sales designation – see page 208.

Performance

(approx. mph / km/h¹⁾)

Engine ²⁾	Z 13 DTJ	Z 17 DTH
Top speed		
5-speed manual transmission	98 / 157	111 / 178
6-speed manual transmission	–	–
Easytronic	–	–

¹⁾ The maximum speed is achievable with a maximum of half payload. Optional equipment may reduce the specified maximum speed of the vehicle.

²⁾ Sales designation – see page 209.

**Fuel consumption,
CO₂ emissions**

Directive 80/1268/EEC (last changed by 1999/100/EC) has applied for the measurement of fuel consumption since 1996.

The directive is oriented to actual driving practices: Urban driving is rated at approx. $\frac{1}{3}$ and extra-urban driving at approx. $\frac{2}{3}$ (urban and extra-urban consumption). Cold starts and acceleration phases are also taken into consideration.

The specification of CO₂ emission is also a constituent of the directive.

The figures given must not be taken as a guarantee for the actual fuel consumption of a particular vehicle.

All values are based on the EU base model with standard equipment.

The calculation of fuel consumption as specified by directive 1999/100/EC takes account of the vehicle's kerbweight, ascertained in accordance with the said regulation. Optional extras may result in slightly higher fuel consumption and CO₂ emission levels than those quoted.

To convert l/100 km into mpg, divide 282 by number of litres/100 km.

Saving fuel, protecting the environment – see page 140.

Fuel consumption, CO₂ emissions

Engine ¹⁾	Z 14 XEP	Z 16 XEP	Z 18 XE	Z 16 LET
5-speed /Sports/6-speed/Easytronic transmission				
Fuel consumption (approx. l/100 km)				
Urban	8.3/-/-	8.8/-/- 8.9	10.9/10.9/-/10.7	-/-/10.4/-
Extra-urban	5.3/-/-	5.5/-/- 5.4	6.1/ 6.6/-/ 6.1	-/-/ 6.3/-
Combined	6.4/-/-	6.7/-/- 6.7	7.9/ 8.2/-/ 7.8	-/-/ 7.8/-
CO ₂ emission (approx. g/km)				
Urban	199/-/-	211/-/-/214	262/ 262/-/ 257	-/-/ 250/-
Extra-urban	127/-/-	132/-/-/130	146/ 158/-/ 146	-/-/ 151/-
Combined	154/-/-	161/-/-/161	190/ 196/-/ 187	-/-/ 187/-

Engine ¹⁾	Z 13 DTJ	Z 17 DTH
5-speed /Sports/6-speed/Easytronic transmission		
Fuel consumption (approx. l/100 km)		
Urban	6.2/-/-	6.6/-/-
Extra-urban	4.3/-/-	4.4/-/-
Combined	5.0/-/-	5.2/-/-
CO ₂ emission (approx. g/km)		
Urban	167/-/-	178/-/-
Extra-urban	116/-/-	119/-/-
Combined	135/-/-	140/-/-

¹⁾ Sales designation – see page 208, 209.

Weights, payload and roof load

The payload is the difference between the permitted Gross Vehicle Weight (see identification plate, page 206) and the EC kerbweight.

To calculate the kerbweight, enter the data for your vehicle below:

■ Kerbweight from Table 1, page 215	+..... kg
■ Weight of heavy accessories from Table 2, page 215	+..... kg
The total	=..... kg

is the EC kerbweight.

Optional equipment and accessories increase the kerbweight, which means that the payload will also change slightly.

Note weight ranges in the vehicle documents and on the rating plate.

The combined total of front and rear axle loads must not exceed the permissible Gross Vehicle Weight. For example, if the front axle is bearing its maximum permissible load, the rear axle can only bear a load that is equal to the Gross Vehicle Weight minus the front axle load.

When the trailer is coupled and the towing vehicle fully loaded (including all occupants), the permissible rear axle load (see identification plate or vehicle documents) may be exceeded by 25 kg and the permissible Gross Vehicle Weight by 25 kg.

If the permissible rear axle load is exceeded, a maximum speed of 60 mph (100 km/h) applies. If national regulations specify a lower maximum speed for vehicles towing a trailer, this must be observed.

See the identification plate or vehicle documents for permissible axle loads.

Roof load

The permissible roof load is 75 kg.

The roof load consists of the weight of the roof rack plus the load carried.

Driving hints – see page 138.

Roof racks * – see page 163.

Table 1, Kerbweight in kg¹⁾

Model	Engine ²⁾	Manual transmission	Easytronic
Meriva	Z 14 XEP	1330	–
	Z 16 XEP	1375	1375
	Z 18 XE	1380	1380
	Z 16 LET	1380	1380
	Z 13 DTJ	1393	–
	Z 17 DTH	1455	–
Meriva with air conditioning system or Electronic Climate Control (ECC) system	Z 14 XEP	1355	–
	Z 16 XEP	1400	1400
	Z 18 XE	1405	1405
	Z 16 LET	1400	1400
	Z 13 DTJ	1418	–
	Z 17 DTH	1480	–

Table 2, Weight of heavy accessories in kg

Accessories	Towing equipment
Weight	25

¹⁾ According to EC Directive 70/156/EC, including assumed weights for driver (68 kg), luggage (7 kg) and all fluids (tank 90% full).

²⁾ Sales designation – see page 208, 209.

Tyres

Restrictions

Not all tyres available on the market currently meet the structural requirements. We recommend that you consult a Vauxhall Authorised Repairer concerning suitable tyre makes.

These tyres have undergone special tests to establish their reliability, safety and specific suitability for Vauxhall vehicles. Despite continuous market monitoring, we are unable to assess these attributes for other tyres, even if they have been granted approval by the relevant authorities or in some other form.

Further information – see page 158.

Winter tyres *

Tyres of size 205/50 R 16 are not suitable for use as winter tyres except on vehicles with the Z 16 LET¹⁾ engine.

Tyres of size 205/45 R 17 are not suitable for use as winter tyres.

¹⁾ Sales designation – see page 208, 209.

If winter tyres are in use, the spare wheel may still be fitted with a summer tyre. Use of the spare wheel may alter vehicle handling. Obtain a replacement for the faulty tyre as soon as possible, and have the wheel balanced and fitted to the vehicle.

Further information – see page 162.

Tyre chains *

Tyre chains may be used on the front wheels only.

We recommend the use of fine-link chains which add no more than 10 mm to the tread and tyre inner wall with (including chain lock).

Tyre chains are not permitted on tyre sizes 205/50 R 16 and 205/45 R 17.

Further information – see page 162.

Wheels

Wheel bolt tightening torque: 110 Nm.

Spare wheel *

Depending on design, the spare wheel is designed as a temporary spare wheel *. When using the spare wheel, the driving behaviour may be modified. Replace the faulty tyre as soon as possible, balance the wheel and refit to vehicle. Follow the notes on this page and on pages 162, 178.

On vehicles with alloy wheels *, the spare wheel may have a steel rim.

The spare wheel may be fitted with a smaller tyre²⁾ and a smaller wheel than the wheels fitted to the vehicle.

Tyre pressure in bar / psi³⁾

The specified tyre pressures are valid for cold tyres. The increased tyre pressure resulting from extensive driving must not be reduced. The tyre pressures specified on the following pages apply to both summer and winter tyres.

The spare wheel must always be inflated to the tyre pressure for a full load – see table on next page.

Further information – see pages 158 to 162.

²⁾ Country-specific version: In some countries, the spare wheel may only be used as a temporary spare wheel.

³⁾ 1 bar corresponds to 100 kPa / 14.5 psi.

(ctd.)

Tyre pressure in bar / psi¹⁾

Engine ¹⁾	Tyres	Tyre pressure for load of up to 3 persons		Tyre pressure for full load	
		Front	Rear	Front	Rear
Z 14 XEP	175/70 R 14, 185/60 R 15, 205/50 R 16, 205/45 R 17	2.4/35	2.2/32	2.6/38	3.0/44
Z 16 XEP	185/60 R 15, 205/50 R 16, 205/45 R 17	2.4/35	2.2/32	2.6/38	3.0/44
Z 18 XE	185/60 R 15, 205/50 R 16, 205/45 R 17	2.4/35	2.2/32	2.6/38	3.0/44
Z 16 LET	185/55 R 16 ²⁾ , 195/50 R 16 ²⁾ , 205/50 R 16, 205/45 R 17	2.8/41	2.6/38	3.0/44	3.4/49
Z 13 DTJ	185/60 R 15, 205/50 R 16, 205/45 R 17	2.4/35	2.2/32	2.6/38	3.0/44
Z 17 DTH	185/60 R 15, 205/50 R 16, 205/45 R 17	2.6/38	2.4/35	2.8/41	3.2/46

¹⁾ 1 bar corresponds to 100 kPa / 14.5 psi.

¹⁾ Sales designation – see page 208, 209.

²⁾ Only permitted as winter tyres.

Electrical system

Battery	Voltage	12 Volt
	Amp hours	44 Ah / 55 Ah * / 60 Ah * / 66 Ah * / 70 Ah *
Battery for radio frequency remote control		CR 20 32

Capacities

(approx. litres)

Engine ¹⁾	Z 14 XEP	Z 16 XEP	Z 18 XE	Z 16 LET
Fuel tank (nominal content)	53	53	53	53
Engine oil with filter change	3.5	4.5	4.25	4.5
Engine oil between MIN and MAX on dipstick	1.0	1.0	1.0	1.0
Windscreen wash system reservoir	2.1	2.1	2.1	2.1
Headlight wash system reservoir ✱	3.5	3.5	3.5	3.5

¹⁾ Sales designation – see page 208, 209.

Capacities

(approx. litres)

Engine¹⁾	Z 13 DTJ	Z 17 DTH
Fuel tank (nominal content)	53	53
Engine oil with filter change	3.2	5.0
Engine oil between MIN and MAX on dipstick	1.0	1.0
Windscreen wash system reservoir	2.1	2.1
Headlight wash system reservoir ✱	3.2	3.5

¹⁾ Sales designation – see page 208, 209.

Dimensions

(mm)

	Meriva	Meriva VXR
Overall length	4052	4068
Overall width	1694	1694
Width including two exterior mirrors	1948	1948
Overall height	1624	1624
Length of luggage compartment floor	861	861
Luggage compartment width	1034	1034
Height of luggage compartment opening	832	832
Wheelbase	2630	2630
Turning circle diameter ¹⁾	10.42	10.42

¹⁾ In metres.

Mounting dimensions of towing equipment *

All measurements refer to Vauxhall-approved towing equipment.

 **Warning**

Only use towing equipment approved for your vehicle. We recommend entrusting retro-fitting of towing equipment to a workshop.

Dimension	mm
A	468
B	727
C	508.1
D	471.5
E	441.4
F	497.6
G	496.6
H	35.1
I	50.1
J	36.4
K	90
L	142.6
M	585
N	568

Dimension	mm
O	425
P	378
Q	14
R	16
S	69
T	76
U	430

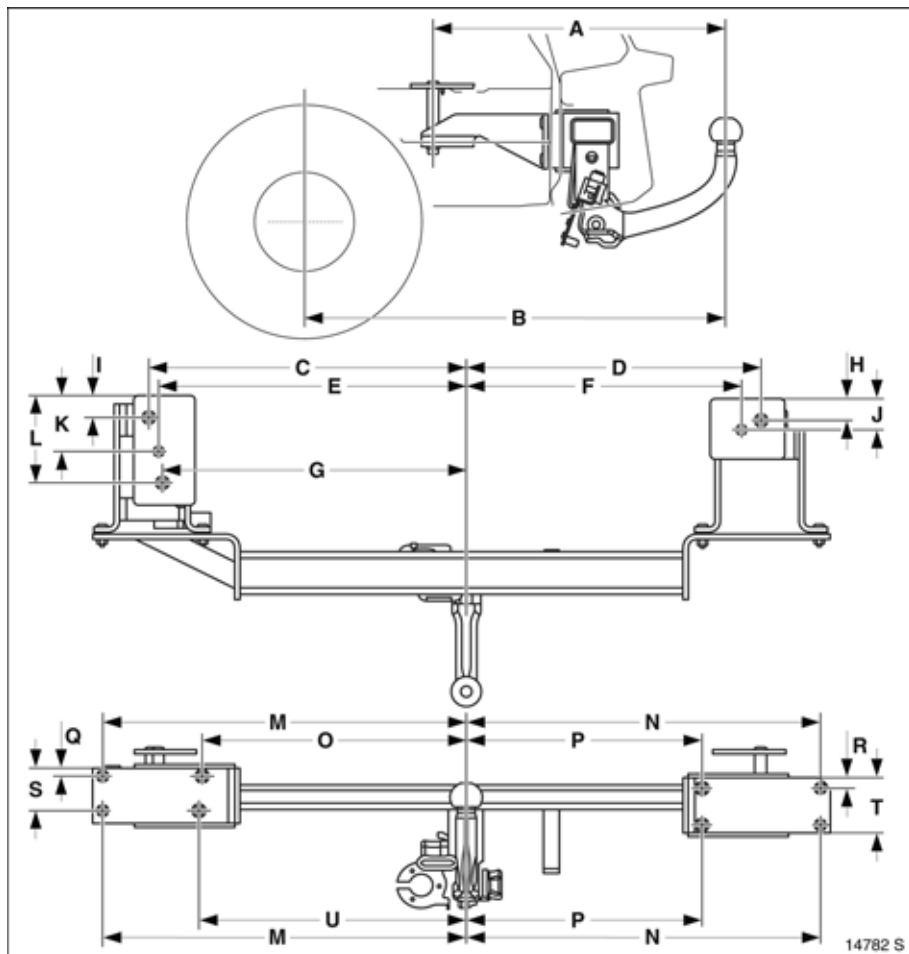

Service, Maintenance

Inspection system	226
Genuine Vauxhall Parts and Accessories	227
A note on safety	227
Checking and topping up fluids	228
Engine oil	228
Diesel fuel filter	230
Coolant	230
Brake fluid	232
Windscreen wiper	233
Windscreen and headlight wash systems *	234
Battery	235
Protecting electronic components	236
Vehicle decommissioning	237
Vehicle recommissioning	237

In our experience, the most common cause of all complaints is the result of misunderstanding or lack of communication between the customer and the Vauxhall Authorised Repairer.

We sincerely hope you will never have cause to complain about your vehicle. However, if things do go wrong, the best course of action for you to take is to contact your Vauxhall Authorised Repairer's Service Reception Staff and explain the difficulty you are having. We are confident they will do their utmost to resolve the problem to your complete satisfaction.

Sometimes, however, despite the best of intentions of all concerned, misunderstandings can occur. If your problem has not been resolved to your satisfaction, please make an appointment to discuss the matter with the Manager of the department concerned.

The majority of areas of concern can be quickly resolved in this way.

Should you wish to pursue the matter further, the Principal of the Vauxhall Authorised Repairer should be made aware of your concern. It is advisable in cases such as this to write to him to confirm your problem and the solutions that have been offered.

You can be assured the Authorised Repairer's Principal will only be too anxious to fully investigate your problems and correct any errors made. After all, he has a

large investment in his business and is proud of his reputation and professionalism and fully realises that satisfied customers are his key to success.

In the unlikely event that you are still not happy with the answer your Vauxhall Authorised Repairer has given, or the action he proposes to correct the problem, you may contact the Customer Care Department¹⁾ where a team of Customer Care Consultants will spare no effort to ensure your complete satisfaction.

Vauxhall Motors Ltd.

Customer Care,
Griffin House,
Osborne Road,
LUTON,
Beds., LU1 3YT
Telephone: 0845 090 2044

They will review all the facts involved. Then if it is felt some further action can be taken, the Vauxhall Authorised Repairer will be advised accordingly. In any case, your contact will be acknowledged confirming Vauxhall Motors' position in the matter.

If you are not satisfied with the outcome, you can if you wish, seek advice from an independent third party such as:

Automobile Association (A.A.)

Fanum House,
BASINGSTOKE,
Hants., RG21 2EA

¹⁾ Calls may be monitored and recorded for training purposes.

Royal Automobile Club (R.A.C.),
R.A.C. Motoring Services Ltd.,
89-91 Pall Mall,
LONDON, SW1Y 5AS

The Customer Relations Department,
Society of Motor Manufacturers and Traders Ltd. (S.M.M.T.),
Forbes House, Halkin Street,
LONDON, SW1X 7DS

Customer Complaints Service,
Scottish Motor Trade Association,
(S.M.T.A.),
3 Palmerston Place,
EDINBURGH, EH12 5AQ

The National Conciliation Service,
Retail Motor Industry Federation,
9 North Street,
RUGBY, CV21 2AB

If you have a problem whilst abroad:
The Service Departments of ADAM OPEL GmbH and General Motors branches everywhere will provide information and assistance:

In **Luxembourg** please contact the General Motors Service Department in Antwerp – Belgium
Telephone 00 32-34 50 63 29

General Motors Austria GmbH
Groß-Enzersdorfer Str. 59
1220 Vienna – Austria
Tel. 00 43 1-288 77 444 or
00 43-1-2 88 77 0

General Motors Belgium N.V.
Noorderlaan 401 – Haven 500
2030 Antwerp – Belgium
Telephone 00 32-34 50 63 29

General Motors Southeast Europe,
org. složka
Olbrachtova 9
140 00 Prague – Czech Republic
Tel. 00 420-2 39 004 321

General Motors Denmark
Jaegersborg Alle 4
2920 Charlottenlund – Denmark
Telephone 00 45-39 97 85 00

Vauxhall Motors Ltd.
Customer Care
Griffin House, Osborne Road
Luton, Bedfordshire, LU1 3YT – England
Tel. 00 44-845 090 2044

General Motors Finland Oy
Pajuniityntie 5
00320 Helsinki – Finland
Tel. 00 358-9 817 101 47

General Motors France
1 – 9, avenue du Marais
Angle Quai de Bezons
95101 Argenteuil Cedex – France
Tel. 00 33-1-34 26 30 51

ADAM OPEL GmbH
Bahnhofspatz 1
65423 Rüsselsheim – Germany
Tel. 00 49-61 42-77 50 00 or
00 49-61 42-7 70

General Motors Hellas S.A.
56 Kifisias Avenue & Delfon str.
Amarousion
151 25 Athens – Greece
Tel 00 30-1-6 80 65 01

General Motors Southeast Europe Ltd.
Szabadsag utca 117
2040 Budaörs – Hungary
Tel. 00 36-23 446 100

General Motors India
Sixth Floor, Tower A, Global Business Park
Mehrauli – Gurgaon Road
Gurgaon – 122 022, Haryana – India
Tel. 00 91-124 280 3333

General Motors Ireland Ltd.
Opel House, Unit 60, Heather Road
Sandyford, Dublin 18 – Ireland
Tel. 00 353-1-216 10 00

General Motors Italia Srl
Piazza dell'Industria 40
00144 Rome – Italy
Tel. 00 39-06-5 46 51

General Motors Nederland B.V.
Lage Mosten 49 – 63
4822 NK Breda – Netherlands
Tel. 00 31-76-5 44 83 00

General Motors Norge AS
Kjeller-Vest 6
2027 Kjeller – Norway
Tel. 00 47-23 50 01 04

General Motors Poland Sp. z o. o.
Domaniewska 41
06-672 Warsaw – Poland
Tel. 00 48- 22-606 17 00

General Motors Portugal
Quinta da Fonte
Edifício Femão Magalhães, Piso 2
2780-190 Paço d'Arcos – Portugal
Tel. 00 351- 21 440 75 00

General Motors Southeast Europe,
org. z ložka
Apollo Business Centre
Mlynské Nivy 45
821 09 Bratislava – Slovakia
Tel. 00 421-2 58 275 543

General Motors España S. L.
Paseo de la Castellana, 91
28046 Madrid – Spain
Tel. 00 34-902 25 00 25

General Motors Norden AB
Årstaängvägen 17
100 73 Stockholm – Sweden
Tel. 00 46-20 333 000

General Motors Suisse S.A.
Stelzenstraße 4
8152 Glattbrugg – Switzerland
Tel. 00 41-44 828 28 80

General Motors Türkiye Ltd. Sti.
Kemalpaşa yolu üzeri
35861 Torbalı/Izmir – Turkey
Tel. 00 90-2 32-8 53-14 53

In **Albania, Bosnia-Herzegovina, Bulgaria, Croatia, Estonia, Latvia, Lithuania, Macedonia, Romania, Serbia-Montenegro and Slovenia** please contact the General Motors Service Department in Budaörs – Hungary
Tel. 00 36-23 446 100



Inspection system

In order to guarantee economical and safe vehicle operation and to maintain the value of your vehicle, it is of vital importance that all maintenance work is carried out at the proper intervals as specified.

For vehicles with fixed oil change and service intervals, **InSP** appears in the odometer display when the ignition is turned on before the service work becomes due: arrange for the next Service to be performed by a workshop within one week or 300 miles (500 km).

The service interval display takes account of off-the-road periods during which the battery is disconnected.

For vehicles with flexible engine oil change and service intervals, the length of these intervals is based on several parameters stemming from usage. For this reason, various engine-specific data is continually gathered and is used to calculate the remaining distance until the next Service.

The distance remaining can be displayed with the ignition turned off: press the reset button for the trip odometer for approx. 2 seconds, **InSP** and the remaining distance appear (see Fig. 17901 S).

If the remaining distance is less than 1000 miles (1500 km), **InSP** is displayed with a remaining distance of 600 miles (1000 km) when the ignition is switched on and off. **InSP** is displayed for several seconds if the remaining distance is less than 600 miles (1000 km). Have the service work that is due carried out within one week or 300 miles (500 km). Have this work carried out by a Vauxhall Authorised Repairer in order to avoid invalidation of warranty claims.

Further information on maintenance and the Service Plan can be found in the Service Booklet, which is in the glove compartment.

Have service work and repairs to the bodywork and components performed properly by a workshop and in accordance with Vauxhall Motors' recommendations, using Genuine Vauxhall Parts and Accessories. We recommend your Vauxhall Authorised Repairer, who has excellent knowledge of Vauxhall vehicles and is in possession of the necessary tools and current Service Instructions from Vauxhall.

To exclude the possibility of loss of warranty, use of a Vauxhall Authorised Repairer is recommended in particular during the warranty period. For further information, see the Service Booklet.

Separate anti-corrosion service

Have the work performed by a workshop at the intervals specified in the Service Booklet.

Genuine Vauxhall Parts and Accessories

We recommend that you use "Genuine Vauxhall Parts and Accessories" and conversion parts released expressly for your vehicle type. These parts have undergone special tests to establish their reliability, safety and specific suitability for Vauxhall vehicles. Despite continuous market monitoring, we cannot assess or guarantee these attributes for other products, even if they have been granted approval by the relevant authorities or in some other form.

"Genuine Vauxhall Parts and Accessories" and conversion parts approved by Vauxhall can be obtained from your Vauxhall Authorised Repairer, who can provide expert advice on permitted technical changes and ensure correct installation.



A note on safety

To avoid injury from moving parts and cables conducting ignition voltage, only carry out engine compartment checks (e.g. checking brake fluid or engine oil level) when the ignition is switched off.

Warning

The cooling fan is controlled by a thermostatic switch and can therefore start unexpectedly even if the ignition is switched off. Risk of injury.

Electronic ignition systems generate very high voltages. Do not touch the ignition system; high voltage can be fatal.

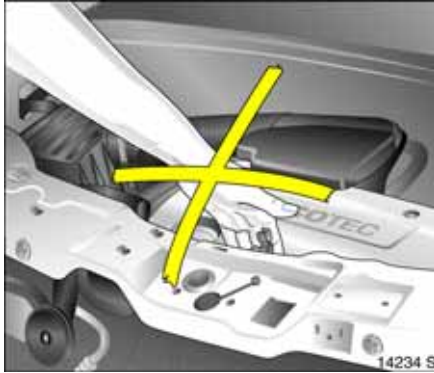

Never carry out any repairs or adjustment and maintenance work on the vehicle yourself. This especially applies to the engine, chassis and safety parts. You may unwittingly infringe the provisions of the law and, by not performing the work properly, endanger yourself and other road users.

Checking and topping up fluids

To aid identification, the caps used when topping up engine oil, coolant and wash fluid as well as the oil dipstick are coloured yellow.

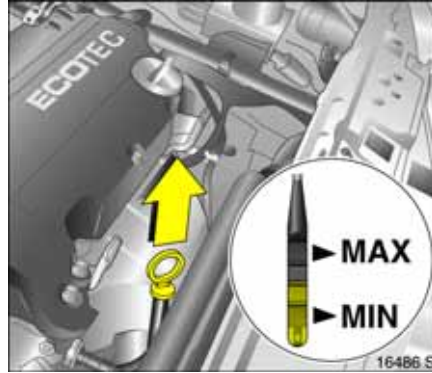

Engine oil

Information on engine oils is found in the Service Booklet.

Engine oil level and consumption

Every engine consumes engine oil for technical reasons. The oil consumption cannot be assessed until a fairly long distance has been driven, and may be above the specified value when the vehicle is first being driven (run-in period). Frequent driving at high revs increases engine oil consumption.

In vehicles with engine oil level check , the engine oil level is checked automatically - see page 88. It is particularly advisable to check the engine oil level before embarking on a long journey.

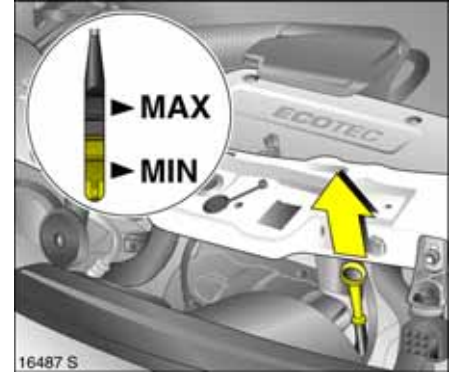

Engine oil level check, topping up engine oil

The oil level must be checked with the vehicle on a level surface and with the engine (which must be at operating temperature) switched off. Wait at least 5 minutes before checking the level, to allow the normal oil accumulation in the engine to drain into the oil pan.

Warning

Important: It is the owner's responsibility to maintain the correct level of an appropriate quality oil in the engine.

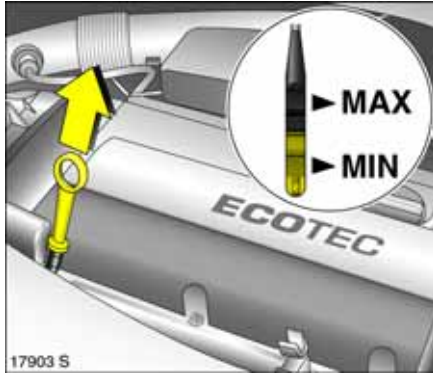

To check the engine oil level, insert wiped oil dipstick into dipstick tube as far as it will go. Top engine oil up if the level has dropped into the range of the top-up mark **MIN**.

The engine oil level must not exceed the upper mark **MAX** on the dipstick. Excess engine oil must be drained off or extracted. If the engine oil level is above the **MAX** mark, there is a risk of damage to the engine or the catalytic converter.

The amount filled must be between the **MIN** and **MAX** marks – see page 219.

Warning

Do not allow the engine oil to drop below the minimum level!

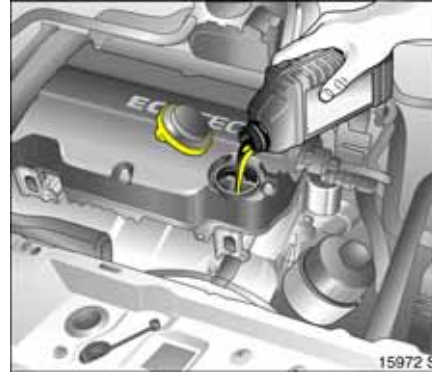

Top up with the same brand of engine oil that was used during the previous oil change, following the instructions in the Service Booklet.

To close, position the cap and screw it into place.

Capacities – see page 219.

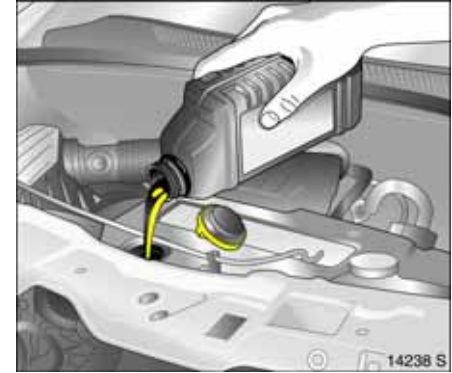

Engine oil change, oil filter change

Have oil changed by a workshop as a function of the service interval display.

We recommend that you use genuine engine oil filters.

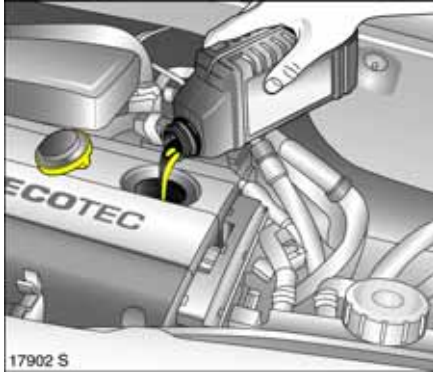

⚠ Warning

Used engine oil cannot be disposed of with domestic refuse. Observe the legal requirements for disposal of old oil and filters, to protect the environment and your health.

Diesel fuel filter

At each engine oil change, have the diesel fuel filter * checked for any water residue by a workshop.

Illumination of control indicator ⚠ indicates water in the diesel fuel filter.

Have diesel fuel filter checked at shorter intervals if the vehicle is subjected to extreme operating conditions, such as high humidity (primarily in coastal areas), extremely high or low outside temperatures, and substantially varying daytime and night-time temperatures.

Coolant

The glycol-based coolant provides excellent corrosion protection for the heating and cooling systems as well as anti-freeze protection down to -28 °C. It remains in the cooling system throughout the year and need not be changed.

Use of certain anti-freezes can lead to engine damage. We therefore recommend that you use only approved anti-freezes.

⚠ Warning

Anti-freeze is a danger to health; it must therefore be kept in the original container and out of the reach of children.

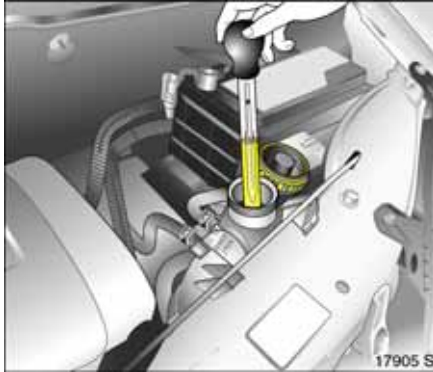

Anti-freeze and corrosion protection

Before the start of winter, have a workshop check the anti-freeze protection. The anti-freeze level must guarantee protection down to approx. -28 °C. Insufficient anti-freeze will reduce the frost protection level and the corrosion protection. If necessary, add anti-freeze.

If coolant loss is topped up with water, have concentration checked and add anti-freeze if necessary.

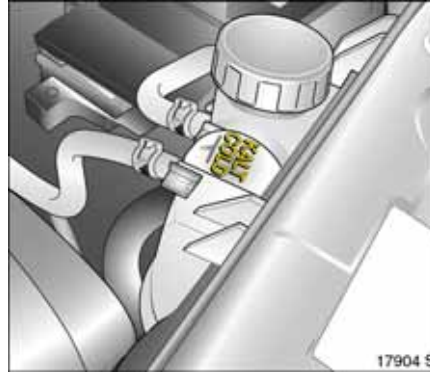

Coolant level

Hardly any losses occur since the cooling system is sealed, and it is thus rarely necessary to top up the coolant.

The coolant should be a little above the **KALT/COLD** mark in the expansion tank with a cold cooling system. The coolant level can also be read off from the outside of the expansion tank.

Warning

Allow engine to cool down before removing coolant filler cap. Remove coolant filler cap carefully so that pressure can escape slowly, otherwise there is a risk of scalding.

When the engine is at operating temperature, coolant level rises. It falls again when the system cools. If it falls below the **KALT/COLD** mark when the system is cold, top up to the mark.

Top up anti-freeze. If no anti-freeze is available, top up with clean tap water. If tap water is unavailable, distilled water can be used.

After filling with tap water or distilled water, measure the anti-freeze concentration and add anti-freeze if required. Have a workshop establish the cause of the coolant loss.

Too low a coolant level can cause engine damage.

To close, position the cap and screw it into place.

Coolant temperature

If the temperature gauge enters the red zone, check the coolant level immediately.

■ Coolant level too low:

Add coolant. See notes under "Anti-freeze and corrosion protection" and "Coolant level". Have a workshop eliminate the cause of the coolant loss.

■ Coolant OK:

Have the cause of the raised coolant temperature eliminated. Contact a workshop.



Brake fluid

Brake fluid level

Warning

Brake fluid is poisonous and corrosive. Do not allow it to come into contact with eyes, skin, fabric or painted surfaces. Direct contact could cause injury and damage.

The brake fluid level in the reservoir must be neither higher than the **MAX** mark nor lower than the **MIN** mark.

Use of certain brake fluids can lead to damage or reduced braking effect. We therefore recommend that you use only approved high-performance brake fluid.

Absolute cleanliness is important when topping up, since contamination in the brake fluid can cause brake system malfunctions.

After correcting the brake fluid level, have a workshop eliminate the cause of the brake fluid loss.

Brake fluid change

Brake fluid is hygroscopic, i.e. it absorbs water. If the brakes become hot, such as when driving on long downhill stretches, vapour bubbles can occur in the water which can have an extremely adverse effect on braking power (depending on the proportion of water).

The brake fluid change intervals specified in the Service Booklet must therefore be observed.

 **Warning**

Have the brake fluid changed by a workshop. Observe the legal requirements for disposal of brake fluid, to protect of the environment and your health.

Windscreen wiper

Clear vision is essential for safe driving.

Therefore, check windscreen wiper and headlight wash/wipe system ✱regularly for cleaning effect. We recommend replacing the wiper blades after a year at most.

If the windows are dirty, operate the windscreen wash before switching the wiper on, in order to prevent wiper blade wear.

Do not switch windscreen wiper on if windows are icy, since this may damage the wiper edges or the wiper system.

If the wiper becomes frozen on to the glass, we recommend that it be released with the aid of Vauxhall De-icer Spray before starting the vehicle, to prevent wiper motor damage.

Smearing wiper blades can be cleaned with a soft cloth and Vauxhall Windscreen Wash Solvent.

Wiper blades whose lips have become hardened, cracked or covered with silicone must be replaced. This may be necessary as a result of the effects of ice, thawing salt or heat, or the incorrect use of cleaning agents.

Switch off windscreen wiper if using a car wash – see pages 11, 204.

Wiper care – see page 204.

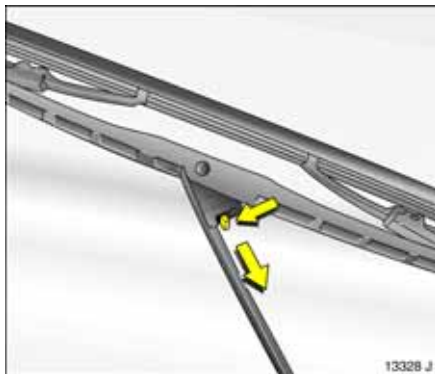

Wiper blades on the windscreen

Lift wiper arm. Move release lever and detach wiper blade.

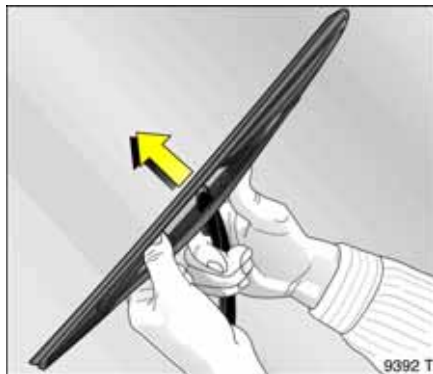

Wiper blade on the rear window *

Lift wiper arm. Disengage wiper blade as shown in illustration and remove.

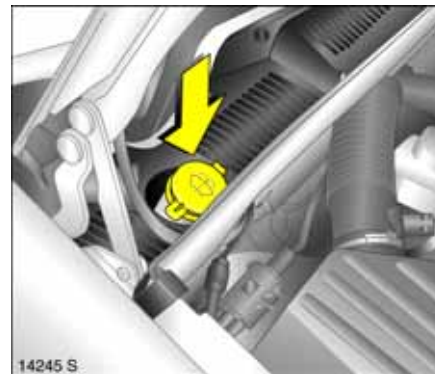

Windscreen and headlight wash systems *

Reservoir for windscreen wash system and rear window wash system in engine compartment beneath the windscreen wiper on the driver's side of the vehicle.



In vehicles with headlight wash system ✱, the opening for refilling is in the engine compartment behind the headlights on the driver's side of the vehicle.

Capacities – see pages 219, 220.

Fill only with clean water to prevent the nozzles from clogging. To improve cleaning efficiency, we recommend that you add a little Vauxhall Windscreen Wash Solvent.

The windscreen wash system and headlight wash system will not freeze in winter:

Frost protection down to	Mixture of Vauxhall Windscreen Wash Solvent: Water
– 5 °C	1 : 3
– 10 °C	1 : 2
– 20 °C	1 : 1
– 30 °C	2 : 1

When closing the reservoir, press the lid firmly over the beaded edge all the way round.

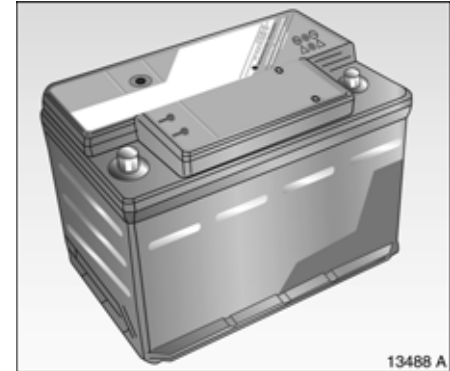

Battery

The battery is maintenance-free.

Warning

Have the battery changed by a workshop. Observe the legal requirements for disposal of old batteries to protect the environment and your health.

Retro-fitting of electrical or electronic accessories can discharge or add extra load to the battery. Obtain advice on the technical possibilities, e.g. use of a more powerful battery, from a workshop.

Parking the vehicle for more than 4 weeks can lead to battery discharging. This may reduce the service life of the battery. Disconnect battery from on-board power supply by disconnecting the negative terminal.

The Vauxhall alarm system * siren must be deactivated as follows: switch the ignition on then off, disconnect the vehicle's battery within 15 seconds.

Ensure ignition is switched off before connecting battery. Then perform the following actions:

- Set date and time in information display – see page 94,
- If necessary, activate the window electronics * – see page 40,
- Calibrate steering angle sensor (ESP^{Plus}) * , see page 150.

In order to prevent the battery from discharging, some consumers such as the courtesy light automatically switch off after approx. 30 minutes.

Protecting electronic components

In order to prevent faults in electronic components in the electrical system, never connect or disconnect battery with engine running or ignition switched on. Never start engine with battery disconnected, e.g. when starting using jump leads.

To avoid damaging the vehicle, do not make any modifications to the electrical system, e.g. connecting additional consumers or tampering with electronic control units (chip tuning).

Warning

Electronic ignition systems generate very high voltages. Do not touch the ignition system; high voltage can be fatal.

Disconnecting/connecting the battery from/to the electrical system

Disconnect the battery from the vehicle electrical system before charging:

First detach the negative and then the positive lead. Do not reverse the polarity of the battery, i.e. do not confuse the terminals for the positive and negative leads. When connecting, start with the positive lead and then connect the negative lead.

Vehicle decommissioning

Observe national regulations.

If the vehicle is to be parked for several months, to avoid damage have the following work performed by a workshop:

- Wash and preserve the vehicle – see page 202,
- Check corrosion protection in engine compartment and on underbody and make good if necessary,
- Clean and preserve rubber seals on bonnet and doors,
- Change engine oil – see page 229,
- Check anti-freeze and corrosion protection – see page 231,
- Check the coolant level, top up with anti-freeze if necessary – see page 231,
- Empty windscreen wash system and headlight wash system * reservoirs,
- Increase tyre pressure to value specified for full load – see page 216.

Vehicle storage

- Park vehicle in a dry and well ventilated place. With manual transmission, select first gear or reverse gear, and with Easytronic *, move selector lever to middle position before switching ignition off. Use wedges or the like to prevent vehicle from rolling.
- Do not apply handbrake,
- Disconnect battery by disengaging negative terminal from vehicle electrical system – see page 236.

Vehicle recommissioning

Observe national regulations.

Perform the following work before recommissioning the vehicle:

- Connect battery – see page 236,
- Check tyre pressure, correct if necessary – see page 216,
- Fill up windscreen wash system and headlight wash system * reservoirs – see page 234,
- Check engine oil level – see page 228,
- Check the coolant level, top up with anti-freeze if necessary – see page 231,
- Fit the number plate, if necessary.

Index

A

ABS (Anti-lock Braking System) 156
 Accessories 176
 Accessory socket 79
 Adaptive brake lights 154
 Adaptive Forward Lighting (AFL) 109
 Bulb replacement 193
 Driving abroad 113
 Air conditioning system 117, 123
 Air intake 131
 Air recirculation system 123, 130
 Air vents 118
 Airbags 67
 Alarm siren 36
 Alternator 87
 Antenna 114, 202
 Anti-corrosion service 226
 Anti-freeze 230
 Anti-freeze protection 230, 234
 Anti-knock quality of fuel 142
 Octane number 208
 Anti-theft alarm system 34
 Anti-theft lock
 Alloy wheels 180
 Anti-theft protection 15
 Aqua planing 161
 Armrest 47
 Ashtray 80, 112
 Automatic anti-dazzle interior mirror 38
 AUX input 115

B

Battery 139, 218, 235
 Interruption of power supply 40, 137
 Battery discharge protection 113
 Before starting-off 14
 Belt tensioners 59
 Bleeding, diesel fuel system 170
 Bonnet 170
 Boot, see Luggage compartment 32, 52
 Brake assist 154
 Brake lights 154, 197
 Brake system 154
 Brakes
 ABS 156
 Adaptive brake lights 154
 Brake assist 154
 Brake fluid 207, 232
 Brake lights 197
 Brake servo unit 138
 Handbrake 15, 155
 Bulb replacement 190

C

Capacities	219, 220
Car Pass	26
Caravan / trailer towing	138
Care	202
Catalytic converter	149, 171
Central locking system	28, 30
Centre console lighting	111, 112
Changing the radio frequency remote control battery	29, 218
Changing tyre / wheel type	158
Changing wheels	178
Chassis number, see Vehicle Identification Number	207
Child restraint systems	65
Child safety locks	36, 40
Cigarette lighter	79, 112
Clutch operation	139
CO ₂ emissions	212
Coin holder	83
Cold start	139
Colour Information Display	95
Contrast	98

Control indicators	8, 84
ABS (Anti-lock Braking System)	157
Adaptive Forward Lighting (AFL)	84, 109
Airbags	72
Belt tensioners	60
Cruise control	151
Engine electronics	147
EPS (Electric Power Steering)	88
ESP (Electronic Stability Program)	149
Exhaust	147
Immobiliser	27
Coolant	230
Coolant level	231
Coolant temperature display	90
Correcting time	97
Coupling socket load	167
Courtesy lights	111
Bulb replacement	200
Cruise control	151
Curtain airbags	71
Curve lighting (AFL)	25, 109

D

Dashboard, see Instrument panel	6
Data	26, 206
Date	94
Daytime running lights	105
Decommissioning	237
Demisting and defrosting Windows	122
With Electronic Climate Control	128
With the air conditioning system	125
Diesel fuel filter	230
Diesel fuel system	170, 230
Diesel particle filter 88, 119, 130, 139, 148	
Dimensions	221
Dipped beam	10
Bulb replacement	191, 193
Display	92
Display mode	99
Door locks	26, 204
Driving abroad	224, 225
Headlights	113
Toll systems	115
Driving hints	138

E

Easytronic 13, 132
 Driving programmes 134
 Fault 137
 Interruption of power supply 137
 Kickdown 135
 Selector lever 13, 133
 Winter programme 135
 Economical driving 140
 Electric Power Steering (EPS) 88
 Towing 173
 Electric windows 39
 Fault 40
 Electrical system 186, 218, 236
 Electronic Climate Control (ECC) 126
 Electronic components 236
 Electronic immobiliser 27
 Electronic Stability Program (ESP) 149
 Engine code 208, 209
 Engine control indicator 147
 Engine oil 228
 Engine oil filter 229
 Engine oil level and
 consumption 208, 209, 228
 Engine oil pressure 86
 Engine speed 139
 Engine wash 205
 Environmental protection 202, 229
 Exhaust control indicator 147
 Exhaust gases 148
 Exhaust system 148
 Exterior mirrors 4, 36, 119

F

Fan 117, 120, 227
 Filling station
 Capacities 219, 220
 Engine oil level 228
 Fuel 208, 209
 Opening the bonnet 170
 Tyre pressure 141, 216
 Vehicle data 206, 207
 Windscreen wash system 234
 First-aid kit 176
 Flat tyre 182
 FlexSpace 51
 Fog tail light 107
 Bulb replacement 197
 Footbrake 154, 155
 Front fog lights 106
 Bulb replacement 196
 Front passenger's airbag 67
 Fuel 142, 208, 209
 Fuel consumption 140, 212
 Fuel filter 230
 Fuel level 90
 Fuel system, diesel 170
 Fuel tank
 Fuel gauge 90
 Fuses 186

G

Gears 13
 Generator, see Alternator 87
 Genuine Vauxhall Parts
 and Accessories 224
 Glasses compartment 82
 Glove compartment 81
 Glove compartment lighting 112
 Bulb replacement 201
 Cooling 119
 Graphical Information Display 92
 Gross Vehicle Weight 214

H

Halogen headlight system 191
 Bulb replacement 191
 Driving abroad 113
 Handbrake 15, 155
 Hazard warning lights 10, 107
 Head restraints 21, 45, 46
 Headlight flash 10
 Headlight range adjustment 107, 190
 Headlight switch 9, 105
 Headlight wash system 11, 104, 234
 Headlights 9
 Changing bulbs 191
 Daytime running lights 105
 Driving abroad 113
 Front fog lights 106
 Reversing lights 107
 Warning device 103

Heated exterior mirrors 12, 119, 130
 Heated rear window 12, 119, 130
 Heated seats 119
 Heating 117, 121
 Seats 119
 With Electronic Climate Control 127
 With the air conditioning system 117
 Height adjustment
 Seat belts 62
 Steering wheel 9
 High-pressure cleaners 166, 203, 205
 Horn 11

I

Identification plate 206, 207
 Ignition system 227, 235, 236
 Immobiliser 27
 Information display 92
 Infotainment system 114
 Instrument display 89
 Instrument illumination 111
 Bulb replacement 201
 Instrument panel 6
 Instruments 6, 84, 89
 Interior mirror 5, 38
 Interruption of power supply 101
 Easytronic 137
 Electric sunroof 42
 Electric windows 40
 Electronic Stability Program 150, 235
 ISO-FIX 64

J

Jack 176, 180
 Jump leads 172

K

Keys 26
 Extending 26
 Ignition lock 14, 27
 Locking doors 28, 30, 36
 Remove 15
 Starting 27
 Starting the engine 14

L

Language selection 97
 Lashing eyes 56
 Leather trim 204
 Light switch 9
 Lighting 9, 105
 Driving abroad 113
 Loading the vehicle 56, 166, 214
 Locking doors 2, 28, 30, 36
 Locks 204
 Lubricants 207, 228
 Luggage compartment 32, 52
 Bulb replacement 201
 Cover 54
 Extension 32, 52
 Lighting 112
 Loading 56, 166, 214
 Lumbar support 44

M

Main beam 10
 Bulb replacement 192, 194
 Control indicator 86
 Maintenance
 Air conditioning system 131
 Anti-freeze protection 230
 Brake fluid 232
 Brakes 154
 Catalytic converter 149
 Engine oil 228, 229
 Fuel consumption 141
 Tyre pressure 159, 216
 Tyres 160
 Windscreen wiper 233
 Manual transmission 13
 Mechanical anti-theft locking system ... 30
 Towing equipment 165
 Mirrors 5, 38
 Misted windows 122, 125, 128
 Mobile telephone 116
 Muffler, see Exhaust system 148

N

Number plate lighting 198
 Bulb replacement 198
 Number plates 237

O

Octane numbers	142, 208, 209
Odometer	89
Oil change	229
Oil filter change	229
Oil level and consumption	208, 209, 228
Oil pressure	86
Operating temperature	139
Outside temperature gauge	93
Overrun	139, 141

P

Paintwork damage	203
Parking	15
Parking distance sensors	153
Parking lights	9
Bulb replacement	195
Parts	224
Pedals	139
Performance	210
Petrol	142
Pinking	142
Pollen filter	131
Power steering, see Electric Power Steering (EPS)	88
Preheating	88
Pushing, towing	171

Q

Quickheat	121, 127
-----------------	----------

R

Radio	24, 114
Radio equipment (CB)	116
Radio frequency remote control.....	28
Central locking system	28
Steering wheel	24, 114
Radio reception	114
Reading lights	112
Rear light cluster	105
Bulb replacement	197
Rear seats	50
Rear window wash system	12, 104, 234
Refuelling	143
Fuel filler cap	144
Replacement keys	26
Reversing lights	107
Bulb replacement	197
Roof load	57, 138, 141, 214
Roof racks	141, 163
Running-in	138
Brakes	154

S

Safeguard against unauthorised use	9, 16, 27, 36
Safety accessories	176
Safety net	55
Safety systems	114
Saving energy	138
Seat adjustment	3, 43, 50
Seat belts	62, 204
Seat height adjustment	3, 44
Seat occupancy recognition	73
Seat position	3, 43, 44
Seats	3, 43
Extending the luggage compartment	32, 52
Heated seats	119
Selector lever	133
Self-diagnosis	60, 73, 157
Self-help Central locking system	31
Electric windows	39
Information display	94
Radio frequency remote control	29
Self-help, vehicle care	170
Service interval display	226
Service work	226
Side airbags	69
Signal system	10, 11
Spare keys	26

Spare wheel	177, 178
Speed	140, 141
Fuel consumption	140, 141
Speedometer	89
Starter switch	14, 27
Starting the engine	9, 27, 133, 171
Self-help	171
Steam-jet cleaners	166, 203, 205
Steering column lock	9, 15
Steering wheel adjustment	9
Steering wheel remote control	24, 114
Stowage compartments	81
Sunroof	41
Fault	42
Sunshade	42
Sunvisors	83
System settings	96

T

Tables	83
Tachometer	89
Tailgate	36
Tail lights	105
Bulb replacement	197
Technical data	206
Telephone, see Mobile telephone	116
Temperature regulation	120, 127
Temporary spare wheel	162, 178
The first 600 miles (1000 km)	138
Tightening torque	182, 216
Time	94
Toll systems	115
Tools	176
Towing	173
Towing equipment	163
Towing eye	173, 175
Trailer / caravan towing	138
Transmission	13
Transmission, Easytronic	132
Driving programmes	134
Fault	137
Interruption of power supply	137
Kickdown	135
Selector lever	13, 133
Winter programme	135
Travel Assistant	22, 47
Tread depth	160
Trip computer	23, 99
Trip odometer	89
Triple Information Display	92
Turn lighting (AFL)	109
Turn signal lights	10, 106
Bulb replacement	196, 197
Twin Audio	24, 115
Tyre chains	162, 216
Tyre condition	160
Tyre pressure	159, 216
Tyre repair kit	182
Tyres	158

U

- Units of measure98
- Unleaded fuel 142, 145, 208, 209
- Used oil 229

V

- Valve cap key 159
- Vauxhall Service224
- Vehicle care 202
- Vehicle decommissioning 237
- Vehicle identification number 207
- Vehicle keys, see Keys26
- Vehicle recommissioning 237
- Ventilation 117, 121, 129

W

- Warning buzzers 103
- Warning triangle 176
- Wash fluid reservoir,
windscreen wash system 234
- Weights 214
- Welcome light function 110
 - Deactivate..... 110
- Wheels 158
- Windows 38
 - Demisting and defrosting .122, 125, 128
- Windscreen wash system 11, 104, 234
 - Anti-freeze protection234
 - Capacities219, 220
 - Wash fluid reservoir 234
- Windscreen wiper 11, 103, 233
- Winter mode
 - Starting-off aid 135
- Winter operation
 - Battery 139
 - Coolant, anti-freeze 230
 - Fuel consumption 141
 - Fuel for diesel engines 142
 - Heating 117
 - Locks 204
 - Tyre chains162, 216
 - Window demisting
and defrosting122, 125, 128
 - Windscreen wash system,
anti-freeze protection234
- Winter programme 135
- Winter tyres 216

X

- Xenon headlight system
 - Bulb replacement 193
 - Driving abroad 113



©Copyright by Vauxhall Motors Ltd., England.

Reproduction or translation, in whole or in parts, is not permitted without prior written consent from Vauxhall Motors Ltd.

All rights as understood under the copyright laws are explicitly reserved by Vauxhall Motors Ltd.

All information, illustrations and specifications contained in this manual are based on the latest production information available at the time of publication.

The right is reserved to make changes at any time without notice.

Edition: January 2007.

TS 1578-B-07

